



McElroy Manufacturing, Inc.

The leader by design.

Tulsa, Oklahoma U.S.A.

DRAWN: TLW

CHECK: DWP

APPR'D: JRP

DATE: 5/11/06

SHT No: 1

REV No: B

PART No: T9000601

### TracStar® 900 SPREADER BAR ASSEMBLY

NOTE: THIS DRAWING AND THE INFORMATION CONTAINED THEREIN IS THE CONFIDENTIAL AND PROPRIETARY PROPERTY OF McElroy Manufacturing, Inc. THE DRAWING IS NOT TO BE REPRODUCED IN ANY MANNER, SUBMITTED TO OUTSIDE PARTIES FOR EXAMINATION, OR USED DIRECTLY OR INDIRECTLY FOR THE PURPOSES OTHER THAN THOSE FOR WHICH IT WAS FURNISHED WITHOUT WRITTEN PERMISSION OF McElroy Manufacturing, Inc.

#### NOTES:

1. THIS ASSEMBLY IS PROOF TESTED AND CERTIFIED TO LIFT SPECIFIED LOAD SHOWN ON THE DRAWING. REPLACEMENT PARTS ARE AVAILABLE ONLY BY SENDING ENTIRE SPREADER BAR ASSEMBLY BACK TO McELROY MFG. AFTER THE REPLACEMENT PARTS HAVE BEEN INSTALLED, THE ASSEMBLY WILL BE PROOF TESTED AGAIN AND RE-CERTIFIED.
2. FOR REPLACEMENT OF # 27 HOOK SAFETY LATCH ONLY ORDER 'MJD00038'.  
FOR REPLACEMENT OF # 25 HOOK SAFETY LATCH ONLY ORDER 'MJD00039'.

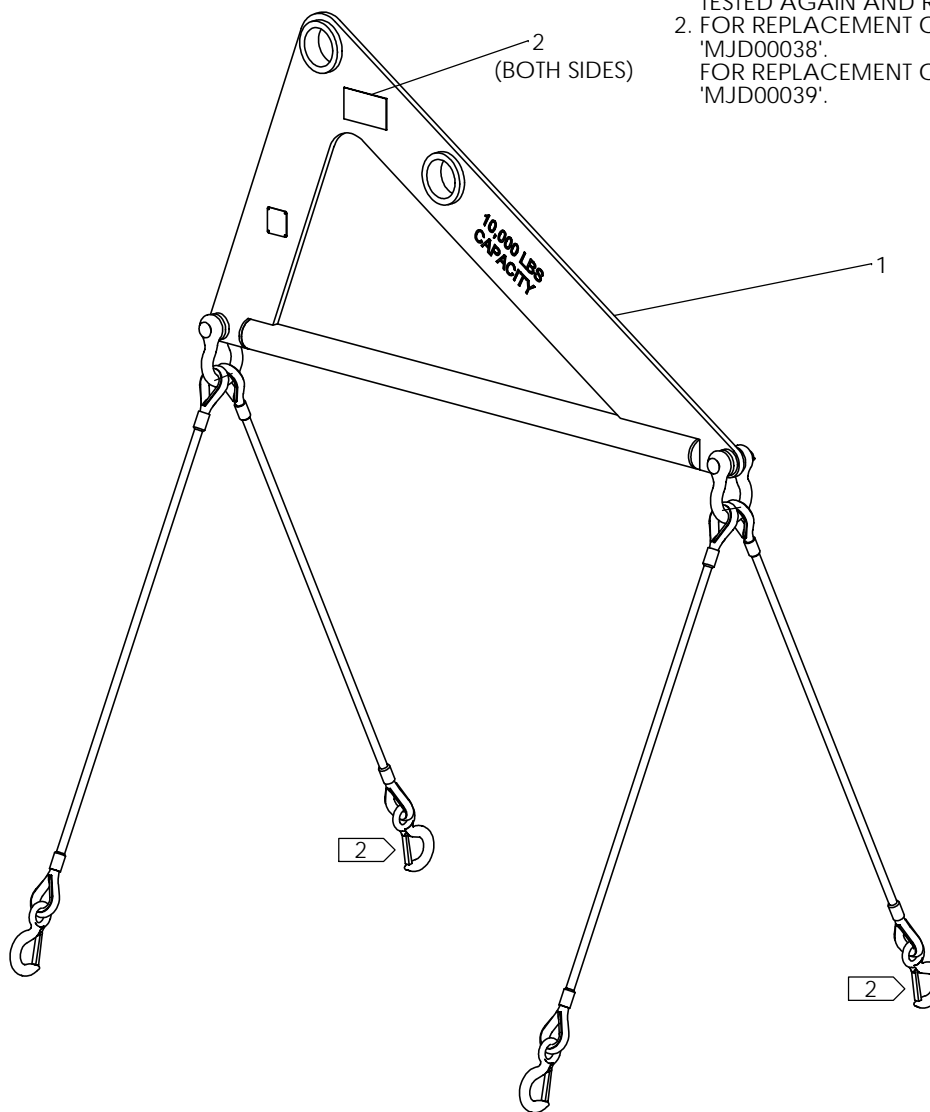

**TracStar® 900 SPREADER BAR ASSEMBLY**Parts List

ITEM	PART NO.	QTY.	DESCRIPTION
	<b>T9000601</b>		<b>ASSEMBLY</b>
1	T9000602	1	SPREADER BAR WELDMENT
2	T9012802	2	SPREADER BAR LABEL

## DRAWING REVISION HISTORY LISTING

**PART NO:** T9000601  
**DESCRIPTION:** TracStar® 900 SPREADER BAR ASSEMBLY

<u>APPR.</u>	<u>REV</u>	<u>DATE</u>	<u>BY</u>	<u>DESCRIPTION OF REVISION</u>
MEP	A	5/17/06	FAW	REDRAWN ON 'A' SIZE. ADDED ITEM NUMBERS AND ITEM 2. REMOVED VENDOR INFORMATION. REMOVED NOTE 1 "SPREADER BAR ASSEMBLY PROOF TEST TO 20,000 LBS". REMOVED NOTE 3 "CABLE ASSEMBLY TO HAVE MECHANICAL SPLICES AND HEAVY-DUTY THIMBLES AT BOTH SIDES". NOTE 2 CHANGED TO NOTE 1.
SWB	B	11/27/06	ARB	REVISED TO ADD NOTE '2' FOR THE REPLACEMENT OF HOOK SAFETY LATCH.