



McElroy Manufacturing, Inc.

The leader by design.

Tulsa, Oklahoma U.S.A.

DRAWN: AH	CHECK: JRP	APPR'D: JRP	DATE: 12/8/97	DWG No: T5008300	SHT No: 1	REV No: C	PART No: T5008301
TracStar 500 HEATER BAG AND FRAME ASSEMBLY							CAD No: T5008301

NOTE: THIS DRAWING AND THE INFORMATION CONTAINED THEREIN IS THE CONFIDENTIAL AND PROPRIETARY PROPERTY OF McElroy Manufacturing, Inc. THE DRAWING IS NOT TO BE REPRODUCED IN ANY MANNER, SUBMITTED OUTSIDE PARTIES FOR EXAMINATION, OR USED DIRECTLY OR INDIRECTLY FOR THE PURPOSES OTHER THAN THOSE FOR WHICH IT WAS FURNISHED WITHOUT WRITTEN PERMISSION OF McElroy Manufacturing, Inc.

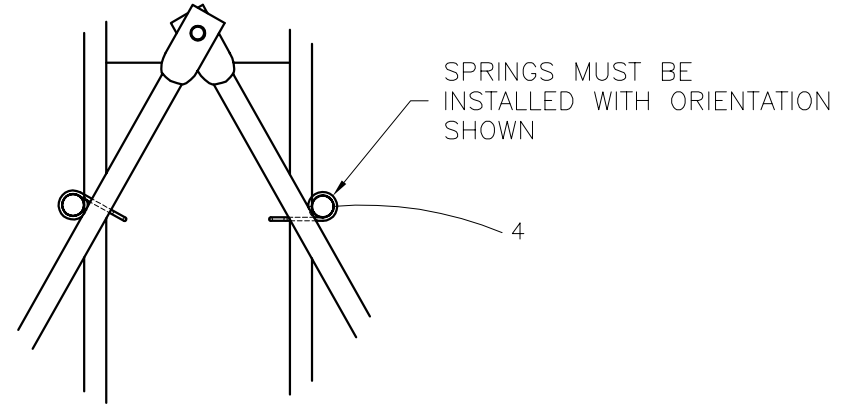
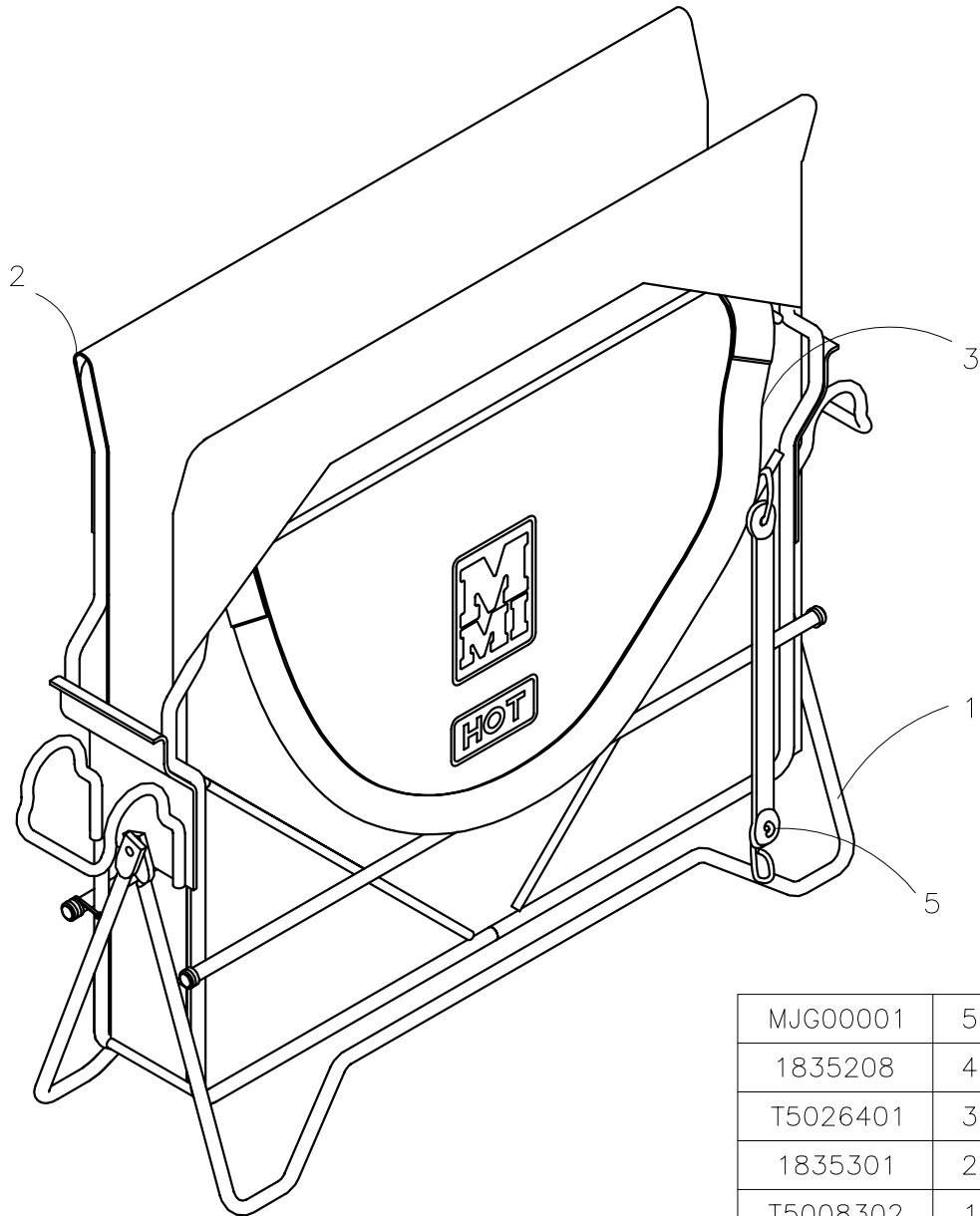

MJG00001	5	1	RUBBER BUNGE CORD
1835208	4	4	LEG RETAINER SPRING
T5026401	3	2	CARRYING STRAP
1835301	2	1	INSULATED HEATER BAG
T5008302	1	1	HEATER BAG FRAME ASSEMBLY
			ASSEMBLY
MMI NUMBER	ITEM	QTY.	SIZE AND DESCRIPTION

UNLESS NOTED OTHERWISE: (3) PLC. DIM'S .XXX = ±0.005" (2) PLC. DIM'S .XX = ±0.010" FRACTIONAL DIM'S = ±1/32" ANGULAR DIM'S = ±1/4" REMOVE ALL BURRS BREAK ALL SHARP EDGES STAMP OR ETCH P/N ON ALL DETAIL PARTS

## DRAWING REVISION HISTORY LISTING

**PART NO:** T5008301

**DESCRIPTION:** TracStar 500 HEATER BAG AND FRAME ASSEMBLY

<u>APPR.</u>	<u>REV</u>	<u>DATE</u>	<u>BY</u>	<u>DESCRIPTION OF REVISION</u>
DWP	A	03/16/98	TLW	ADDED ITEM #3(822001) CARRYING STRAP.
DWP	B	09/22/98	TLW	REVISED ITEM #3(822001) TO (T5026401) CARRYING STRAP.
SWB	C	01/14/03	BWW	REVISED TO ADD ITEM 4 1835208 QTY 4 AND ITEM 5 MJG00001 QTY 1. PARTS ADDED FOR CONSISTENCY BETWEEN OTHER BAG FRAMES.