



McElroy Manufacturing, Inc.
 The leader by design.
 Tulsa, Oklahoma U.S.A.

DRAWN: TLW	CHECK: BWP	APPRV'D: SWB	DATE: 02/27/01	DWG No: 1808500	SHT No: 4	REV No: A	PART No: 1808504
#618/TracStar 500 STUB END HOLDER ASSEMBLY							CAD No: 1808504

NOTE: THIS DRAWING AND THE INFORMATION CONTAINED THEREIN IS THE CONFIDENTIAL AND PROPRIETARY PROPERTY OF McElroy Manufacturing, Inc. THE DRAWING IS NOT TO BE REPRODUCED IN ANY MANNER, SUBMITTED OUTSIDE PARTIES FOR EXAMINATION, OR USED DIRECTLY OR INDIRECTLY FOR THE PURPOSES OTHER THAN THOSE FOR WHICH IT WAS FURNISHED WITHOUT WRITTEN PERMISSION OF McElroy Manufacturing, Inc.

NOTES:
 1. MAX. FLANGE DIA. = 23.03 . 500mm STUB ENDS MAY REQUIRE MODIFICATION FOR USE IN TracStar 500 FUSION MACHINE.

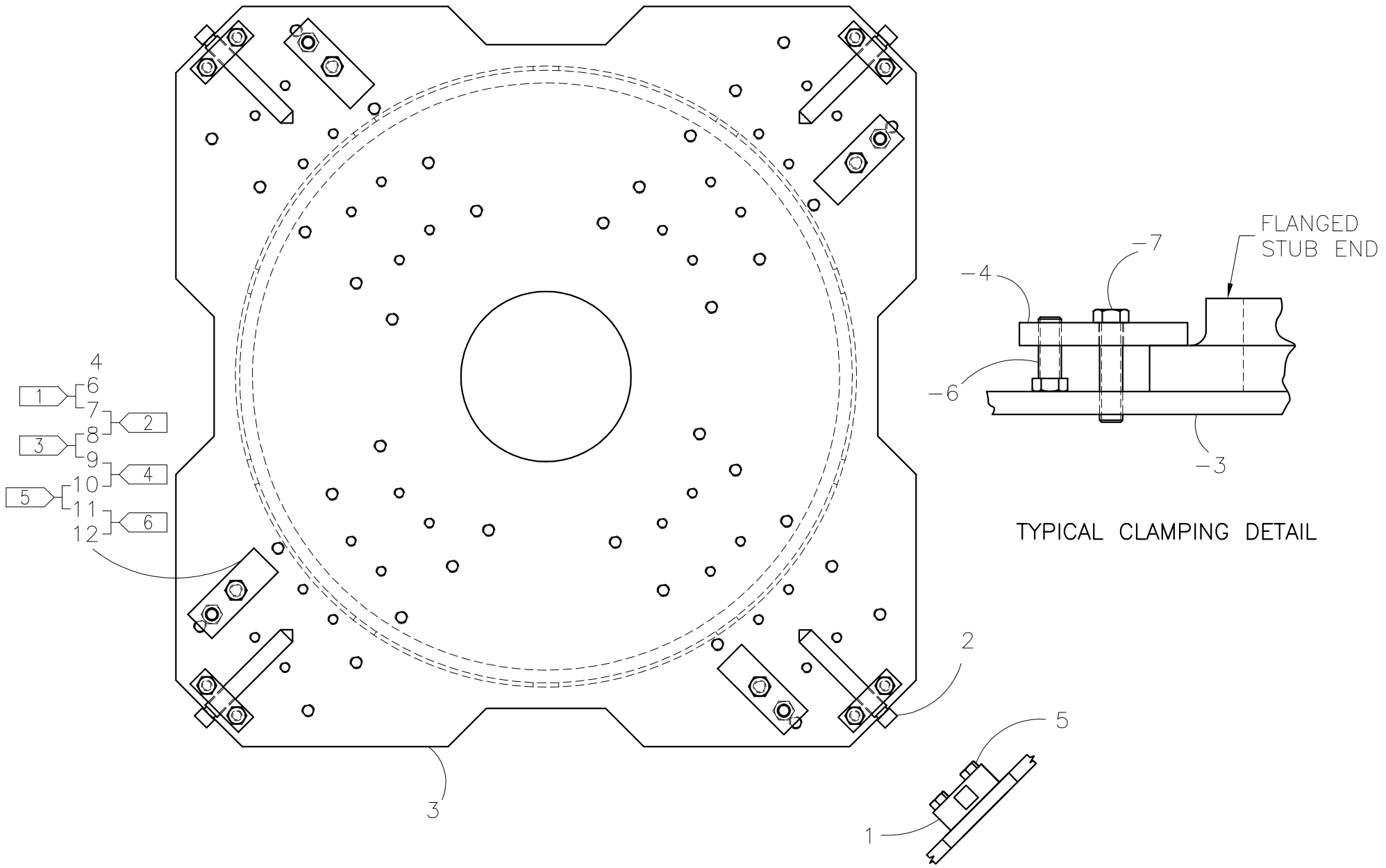

#618/TracStar 500 STUB END HOLDER ASSEMBLYParts List

ITEM	PART NO.	QTY.	DESCRIPTION
	1808504		ASSEMBLY
1	805401	4	STUB END HOLDER CLAMP BLOCK
2	805703	4	STUB END HOLDER ADJUSTMENT SCREW
3	1808505	1	STUB END HOLDER WELDMENT
4	1808506	4	STUB END CLAMP
5	MAB00033	8	5/16-18NC X 1" LG HHCS
6	MAB00064	4	3/8-16NC X 1" LG HHCS
7	MAB00066	4	3/8-16NC X 1 1/2" LG HHCS
8	MAB00068	4	3/8-16NC X 2" LG HHCS
9	MAB00071	4	3/8-16NC X 2 1/2" LG HHCS
10	MAB00094	4	3/8-16NC X 3" LG HHCS
11	MAB00072	4	3/8-16NC X 3 1/2" LG HHCS
12	MAB00073	4	3/8-16NC X 4" LG HHCS

NOTES:

1. USE ITEMS 6 & 7 FOR FLANGED STUB ENDS THAT ARE LESS THAN 3/4" THICK.
2. USE ITEMS 7 & 8 FOR FLANGED STUB ENDS THAT ARE 3/4" TO LESS THAN 1 1/4" THICK.
3. USE ITEMS 8 & 9 FOR FLANGED STUB ENDS THAT ARE 1 1/4" TO LESS THAN 1 3/4" THICK.
4. USE ITEMS 9 & 10 FOR FLANGED STUB ENDS THAT ARE 1 3/4" TO LESS THAN 2 1/4" THICK.
5. USE ITEMS 10 & 11 FOR FLANGED STUB ENDS THAT ARE 2 1/4" TO LESS THAN 2 3/4" THICK.
6. USE ITEMS 11 & 12 FOR FLANGED STUB ENDS THAT ARE 2 3/4" TO LESS THAN 3 1/4" THICK.

DRAWING REVISION HISTORY LISTING

PART NO: 1808504

DESCRIPTION: #618/TracStar 500 STUB END HOLDER ASSEMBLY

<u>APPR.</u>	<u>REV</u>	<u>DATE</u>	<u>BY</u>	<u>DESCRIPTION OF REVISION</u>
SWB	A	9/14/01	RLE	ADDED SIDE VIEW OF CLAMP BLOCK.