



McElroy Manufacturing, Inc.
 The leader by design.
 Tulsa, Oklahoma U.S.A.

| | | | | | | | |
|--|------------|------------|--------------|----------------|-----------|-----------|-----------------|
| DRAWN: AH | CHECK: JRP | APPRV'D: B | DATE: 2/7/97 | DWG No: 848700 | SHT No: 1 | REV No: B | PART No: 848701 |
| #28 DIPS LW HEATER ASSY 120V, 50/60Hz, 1Ph | | | | | | | CAD No: 848701 |

NOTE: THIS DRAWING AND THE INFORMATION CONTAINED THEREIN IS THE CONFIDENTIAL AND PROPRIETARY PROPERTY OF McElroy Manufacturing, Inc. THE DRAWING IS NOT TO BE REPRODUCED IN ANY MANNER, SUBMITTED OUTSIDE PARTIES FOR EXAMINATION, OR USED DIRECTLY OR INDIRECTLY FOR THE PURPOSES OTHER THAN THOSE FOR WHICH IT WAS FURNISHED WITHOUT WRITTEN PERMISSION OF McElroy Manufacturing, Inc.

ELECTRICAL SCHEMATIC

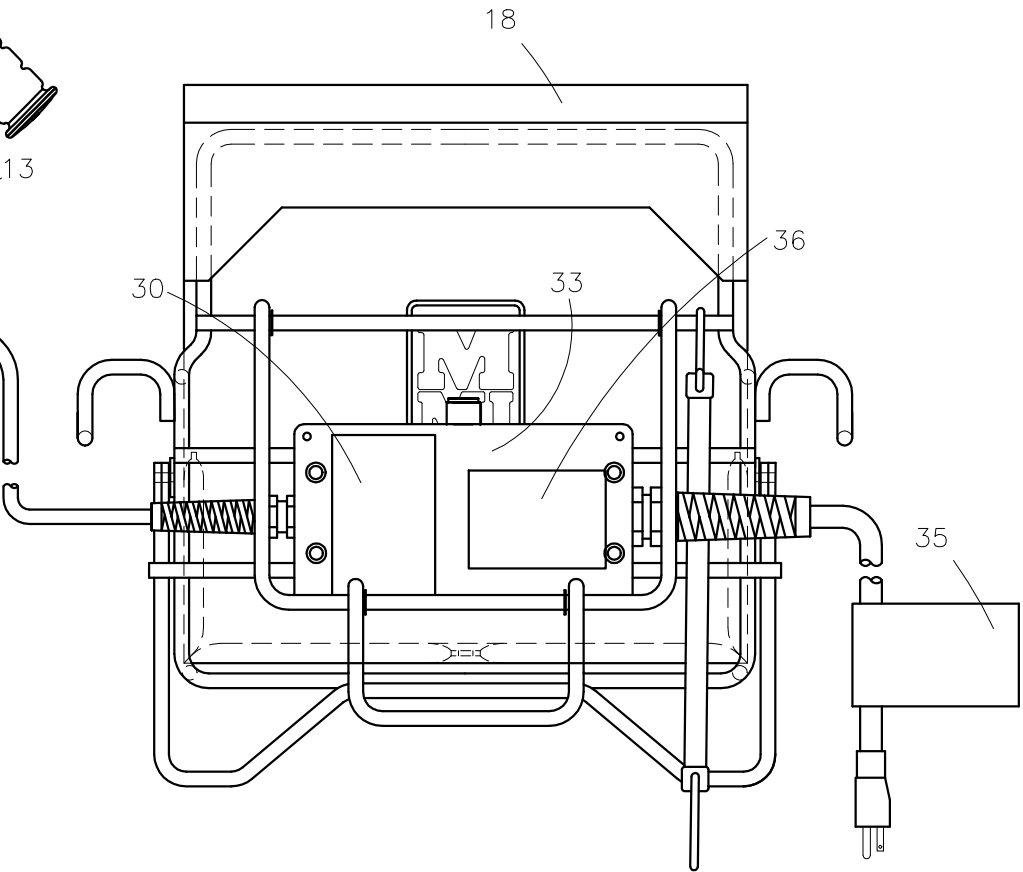
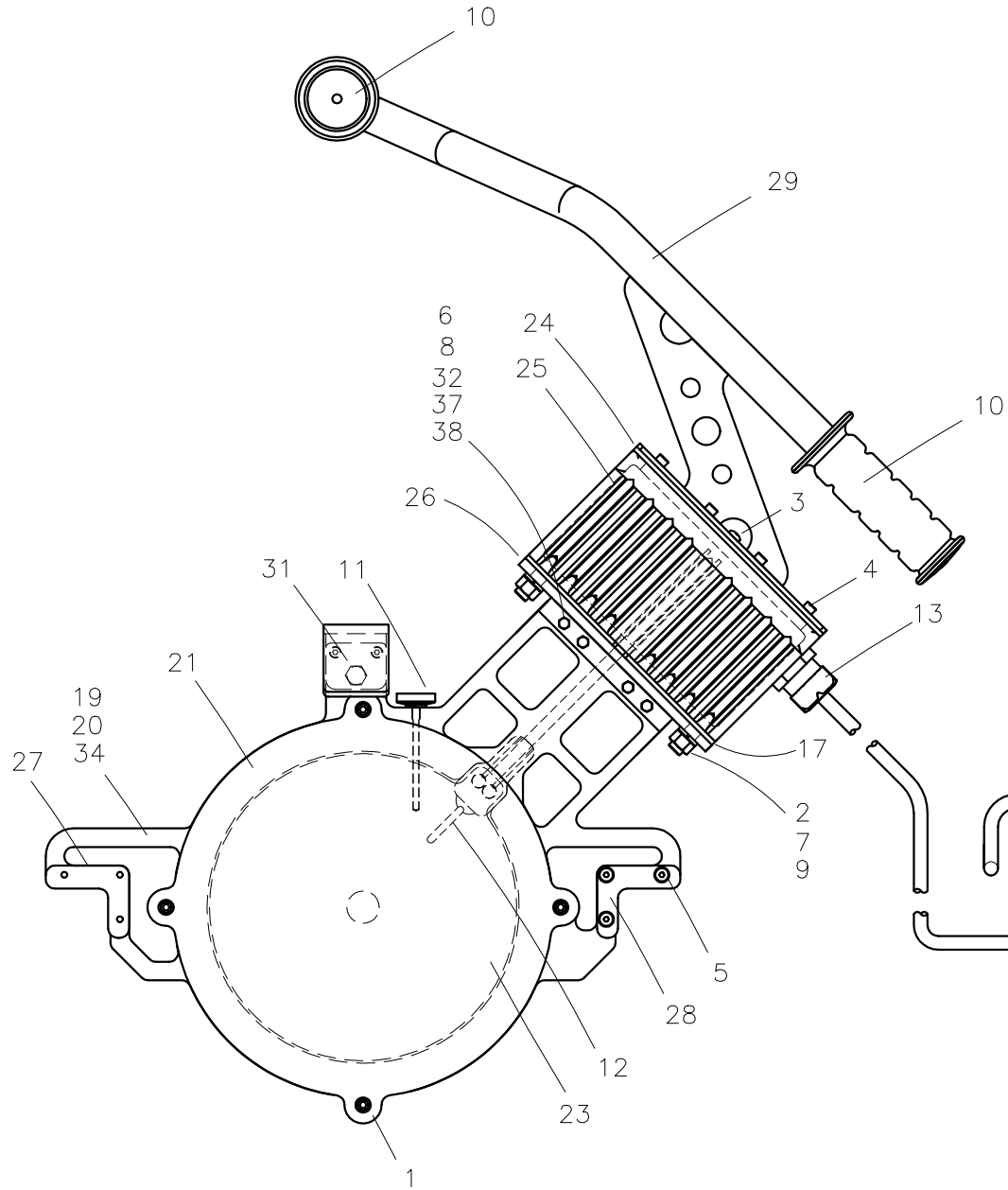
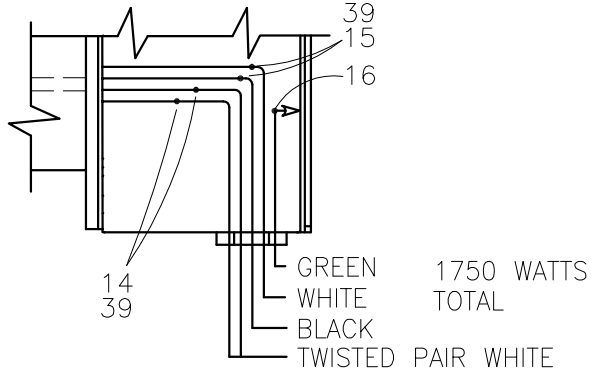

**#28 DIPS LW HEATER ASSY
120V, 50/60Hz, 1Ph**

Parts List

| ITEM | PART NO. | QTY. | DESCRIPTION |
|------|---------------|------|--|
| | 848701 | | ASSEMBLY |
| 1 | A848706 | 1 | #28 DIPS LW HEATER BUTT PLATE KIT |
| 2 | MAC00095 | 2 | 3/8-16NC X 1-1/4"LG SHCS STL PL |
| 3 | MAH00030 | 1 | #10-24NC X 1/4"LG RHSMS SS |
| 4 | MAH00046 | 8 | #10-24 X 1/2"LG SHCS 18-8SS |
| 5 | MAN00036 | 6 | #10-32NF X 7/8"LG. FHSCS SS |
| 6 | MBA00004 | 4 | #10-24NC FINISHED HEX NUT STL PL |
| 7 | MBA00007 | 2 | 3/8-16NC FINISHED HEX NUT STL PL |
| 8 | MBE00004 | 4 | #10 REG SPLIT LK WASHER STL PL |
| 9 | MBE00007 | 2 | 3/8" REG SPLIT LK WASHER STL PL |
| 10 | MJJ00009 | 2 | HAND GRIP |
| 11 | MJK00002 | 1 | THERMOMETER |
| 12 | MKI00003 | 1 | 100 OHM PLATINUM RTD |
| 13 | MLK00022 | 1 | 1/2" STRAIN RELIEF CONNECTOR |
| 14 | MJQ00046 | 2 | FERRULE |
| 15 | MJQ00026 | 2 | FERRULE |
| 16 | MLM00013 | 1 | CONNECTOR |
| 17 | 1207302 | 1 | GASKET-TERMINAL ENCLOSURE |
| 18 | 821802 | 1 | #28 LW HEATER BAG ASSEMBLY |
| 19 | 848703 | 1 | #28 LW HEATER BODY (RIGHT) |
| 20 | 848704 | 1 | #28 LW HEATER BODY (LEFT) |
| 21 | 848705 | 1 | #28 LW HEATER O.D. SPACER |
| 22 | | | |
| 23 | 838008 | 1 | #28 LW HEATER MICA/FOIL ELEMENT |
| 24 | 1808102 | 1 | GASKET |
| 25 | 1810905 | 1 | #28 LW HEATER TERMINAL ENCLOSURE |
| 26 | 1852008 | 1 | LW HEATER TERMINAL ENCLOSURE ADAPTER BRACKET |
| 27 | 1852011 | 2 | LW HEATER GUIDE ROD SUPPORT BRACKET |
| 28 | 1852012 | 2 | LW HEATER GUIDE ROD SUPPORT BRACKET |
| 29 | 838007 | 1 | #28 LW HEATER HANDLE ASSEMBLY |
| 30 | 838016 | 1 | LABEL-WARNING NOT EXPLOSION PROOF |
| 31 | A848707 | 1 | #28 STRIPPER BAR KIT |
| 32 | MAN00008 | 4 | #10-24NC X 1" LG SHCS SS |
| 33 | 838014 | 1 | #28 LW HEATER ELECTRICAL ASSEMBLY |
| 34 | MAN00023 | 13 | #8-32NC X 5/16 LG SHCS SS |
| 35 | 410906 | 1 | DANGER NOT EXPLOSION PROOF TAG LABEL |
| 36 | 841202 | 1 | MODEL 848701 PART NUMBER LABEL |
| 37 | 1852017 | 1 | LW HEATER .004 THICK SHIM |
| 38 | 1852018 | 1 | LW HEATER .018 THICK SHIM |
| 39 | MLN00219 | 1ft | FIBERGLASS TAPE |

DRAWING REVISION HISTORY LISTING

PART NO: 848701

DESCRIPTION: #28 DIPS LW HEATER ASSEMBLY

| <u>APPR.</u> | <u>REV</u> | <u>DATE</u> | <u>BY</u> | <u>DESCRIPTION OF REVISION</u> |
|--------------|------------|-------------|-----------|--|
| TLW | A | 11/4/98 | MLM | ADDED ITEMS 37 (1852017) AND 38 (1852018). |
| SWB | - | 04/17/00 | TLW | REVISED ITEM #5 MAN00016 #10-32NF X 3/4 LG FHSCS SS TO MAN00036 #10-32NF X 7/8 LG FHSCS SS. DUE TO STACK-UP OF TOLERANCES, MAN00016 COULD BE TOO SHORT. |
| RAD | B | 09/14/01 | BWW | REVISED TO CHANGE ITEM 14 FROM MLM00002 TO MJQ00046 AND ITEM 15 FROM MLM00010 TO MJQ00026,ALSO ADDED ITEM 39 MLN00219 TO IMPROVE TEMPERATURE RESISTANCE OF WIRE SPLICES. |