



McElroy Manufacturing, Inc.
 The leader by design.
 Tulsa, Oklahoma U.S.A.

DRAWN: AH	CHECK: TLW	APPRVD: SWB	DATE: 3/5/99	DWG No:	SHT No:	REV No: B	PART No:
Sidewinder FUSION MACHINE GROUPING FOR SW00100 ASSEMBLIES							CAD No: _ASSYSW

NOTE: THIS DRAWING AND THE INFORMATION CONTAINED THEREIN IS THE CONFIDENTIAL AND PROPRIETARY PROPERTY OF McElroy Manufacturing, Inc. THE DRAWING IS NOT TO BE REPRODUCED IN ANY MANNER, SUBMITTED OUTSIDE PARTIES FOR EXAMINATION, OR USED DIRECTLY OR INDIRECTLY FOR THE PURPOSES OTHER THAN THOSE FOR WHICH IT WAS FURNISHED WITHOUT WRITTEN PERMISSION OF McElroy Manufacturing, Inc.

- 1 - SW13501 Sidewinder COMMON COMPONENTS ASSEMBLY
- 2 - SW13601 Sidewinder STANDARD GUIDE ROD & DRIVE SCREW ASSEMBLY
- 2 - SW13602 Sidewinder COMPACT GUIDE ROD & DRIVE SCREW ASSEMBLY
- 3 - ASW13102 600 psi Sidewinder GAUGE KIT (NO DRAWING)
- 3 - ASW13103 1500 psi Sidewinder GAUGE KIT (NO DRAWING)
- 3 - ASW13104 300 psi Sidewinder GAUGE KIT (NO DRAWING)
- 3 - ASW13105 1000 psi Sidewinder GAUGE KIT (NO DRAWING)
- 4 - SW04701 3" PIVOT RELEASE MASTER INSERT ASSEMBLY
- 4 - SW07301 4" PIVOT RELEASE MASTER INSERT ASSEMBLY (OPTIONAL)
- 5 - ASW10201 Sidewinder JAW CLAMP ASSEMBLY
- 5 - ASW10301 Sidewinder CHAIN CLAMP ASSEMBLY
- 6 - 214905 2" Multi-Mc SIDEWALL & SOCKET HEATER ASSEMBLY 100-120V, 50/60Hz, 1Ph
- 6 - 214906 2" Multi-Mc SIDEWALL & SOCKET HEATER ASSEMBLY 200-240V, 50/60Hz, 1Ph
- 7 - 424315 #14 Multi-Mc SIDEWALL & SOCKET HEATER ASSEMBLY 100-120V, 50/60Hz, 1Ph
- 7 - 424316 #14 Multi-Mc SIDEWALL & SOCKET HEATER ASSEMBLY 200-240V, 50/60Hz, 1Ph

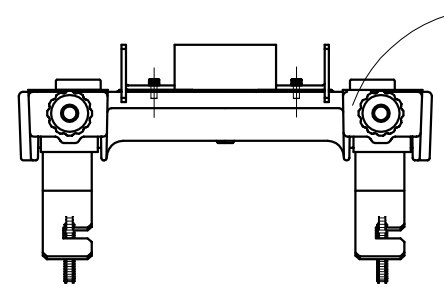
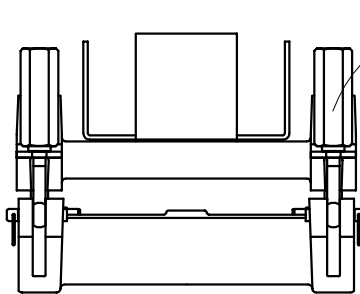
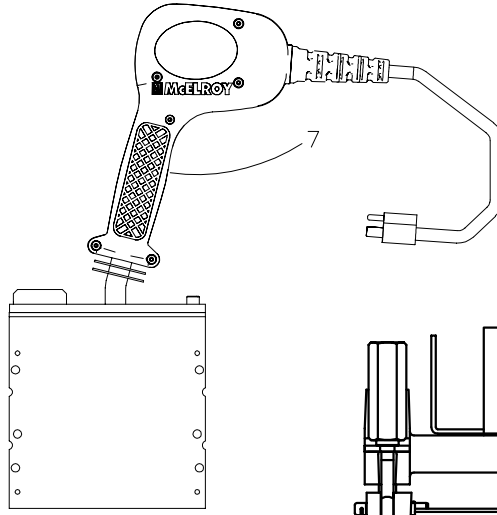
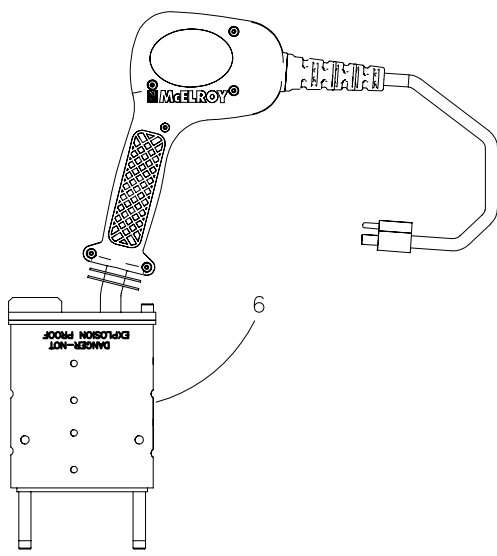
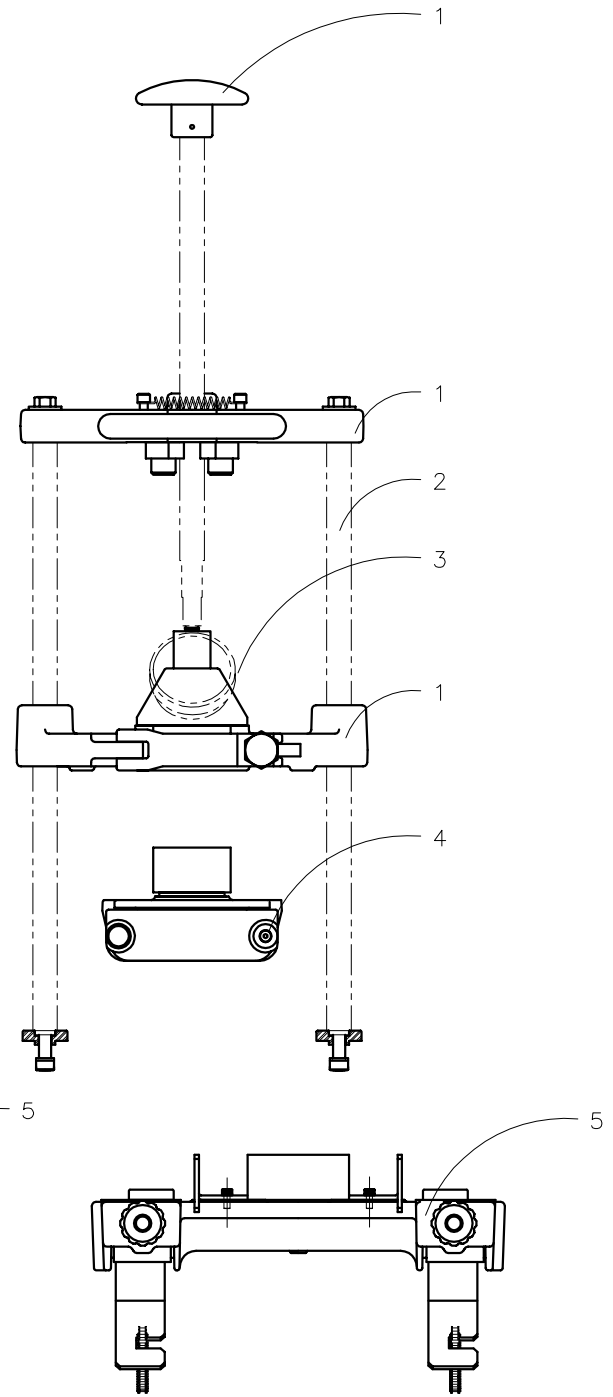

DRAWING REVISION HISTORY LISTING

PART NO: _ASSYSW

DESCRIPTION: Sidewinder FUSION MACHINE GROUPING DRAWING FOR SW00100 ASSEMBLIES

<u>APPR.</u>	<u>REV</u>	<u>DATE</u>	<u>BY</u>	<u>DESCRIPTION OF REVISION</u>
TMT	A	05/16/02	BWW	REVISED TO REPLACE 214901 WITH 214903, 214902 WITH 214904, 424308 WITH 424311 AND 424309 WITH 424312 TO SHOW NEW HEATER ASSEMBLIES WITH ELECTRONIC CONTROL.
SWB	B	08/22/05	BWW	UPDATED ITEMS 6 AND 7 TO NEW STYLE HEATERS WITH SHORTER HANDLES.