



McElroy Manufacturing, Inc.

The leader by design.

Tulsa, Oklahoma U.S.A.

DRAWN: TLW

CHECK: BWP

APPRVD: B

DATE: 5/18/95

SHT No: 1

REV No: J

PART No: SW04701

3" IPS PIVOT RELEASE MASTER INSERT ASSEMBLY

NOTE: THIS DRAWING AND THE INFORMATION CONTAINED THEREIN IS THE CONFIDENTIAL AND PROPRIETARY PROPERTY OF McElroy Manufacturing, Inc. THE DRAWING IS NOT TO BE REPRODUCED IN ANY MANNER, SUBMITTED TO OUTSIDE PARTIES FOR EXAMINATION, OR USED DIRECTLY OR INDIRECTLY FOR THE PURPOSES OTHER THAN THOSE FOR WHICH IT WAS FURNISHED WITHOUT WRITTEN PERMISSION OF McElroy Manufacturing, Inc.

NOTES:

1. INSTALL ITEM 1 INTO ITEM 9 WITH MEDIUM STRENGTH THREAD LOCKER SO THAT 2 7/16" OF STUD IS EXPOSED.
2. STAKE HOLES TO RETAIN PIN.
3. ADJUST ANGULARITY BETWEEN ITEM 12 AND ITEM 9 PER ES-102.

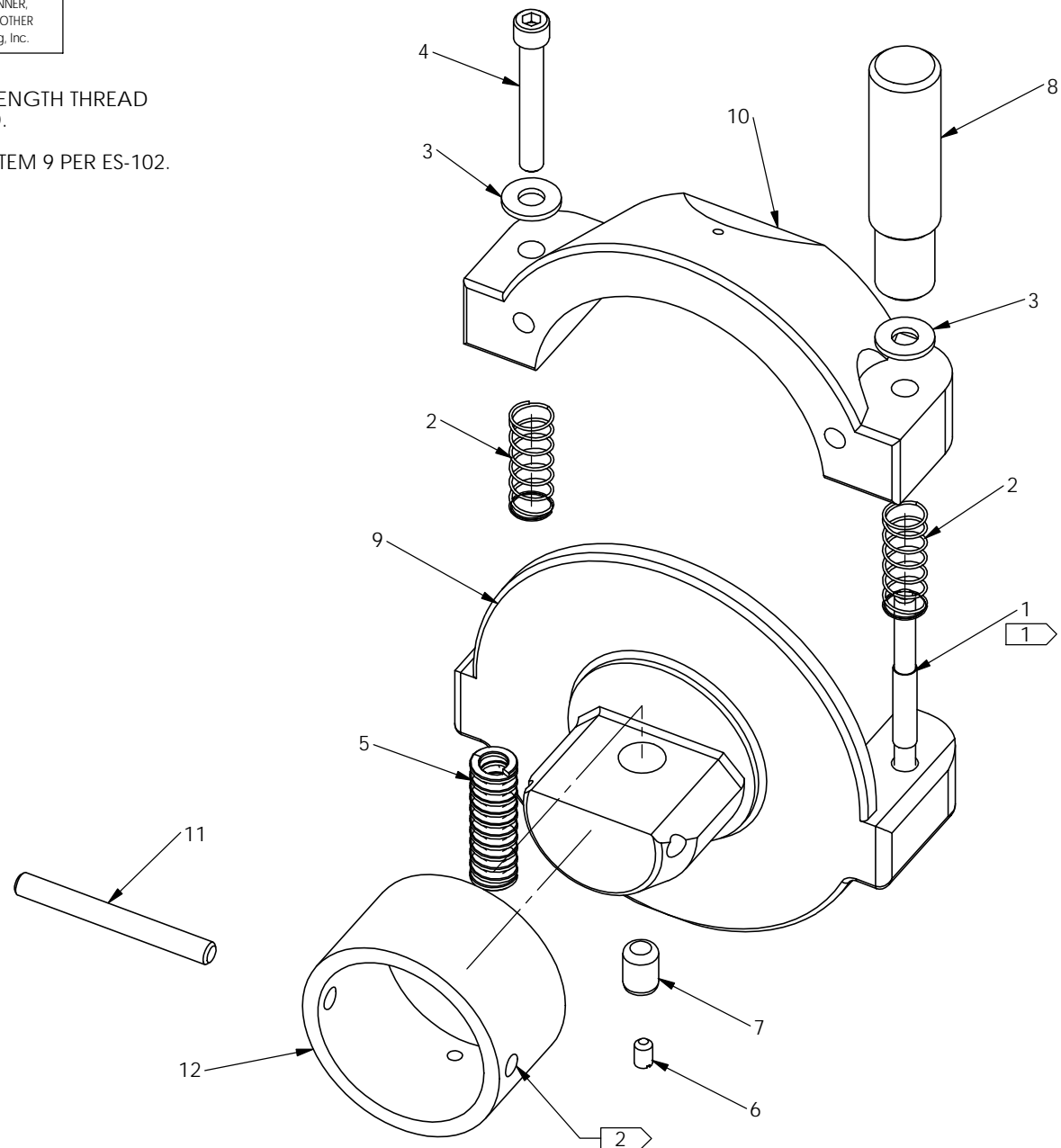

3" IPS PIVOT RELEASE MASTER INSERT ASSEMBLYPARTS LIST

ITEM	PART NO.	QTY	DESCRIPTION
	SW04701		Assembly
1	MJQ00028	1	1/4-20NC x 3 TYPE 2 DOUBLE END STUD
2	MJE00006	2	SPRING
3	MBF00005	2	1/4 TYPE A WIDE FLAT WASHER
4	MAC00058	1	1/4-20 NC x 1-3/4" LG. SHCS
5	MJE00007	1	SPRING
6	MAG00013	1	#10-32NF x 1/4" Lg. SOCKET SET SCREW
7	MCI00008	1	3/8" Dia. x 1/2" LG. DOWEL PIN
8	SW05501	1	INSERT BODY HAND KNOB
9	SW04703	1	3 IPS PIVOT RELEASE BODY
10	SW04705	1	3 IPS PIVOT RELEASE CLAMP
11	SW04707	1	PIVOT RELEASE MASTER INSERT PIVOT PIN
12	SW04706	1	PIVOT RELEASE MASTER INSERT SLEEVE

DRAWING REVISION HISTORY LISTING

PART NO: SW04701

DESCRIPTION: 3" IPS PIVOT RELEASE MASTER INSERT ASSEMBLY

<u>APPR.</u>	<u>REV</u>	<u>DATE</u>	<u>BY</u>	<u>DESCRIPTION OF REVISION</u>
B	H	5/18/95	TLW	SCANNED AND REDUCED TO 'A' SIZE FORMAT. CREATED TYPED PARTS LIST.
SWB	J	05/12/05	BWW	CREATED EXPLODED ISOMETRIC VIEW FOR CLARITY. REMOVED NOTE FOR INSERT SETS WHICH IS NOT NECESSARY AND UPDATED OTHER NOTES TO CURRENT SPECIFICATION.