

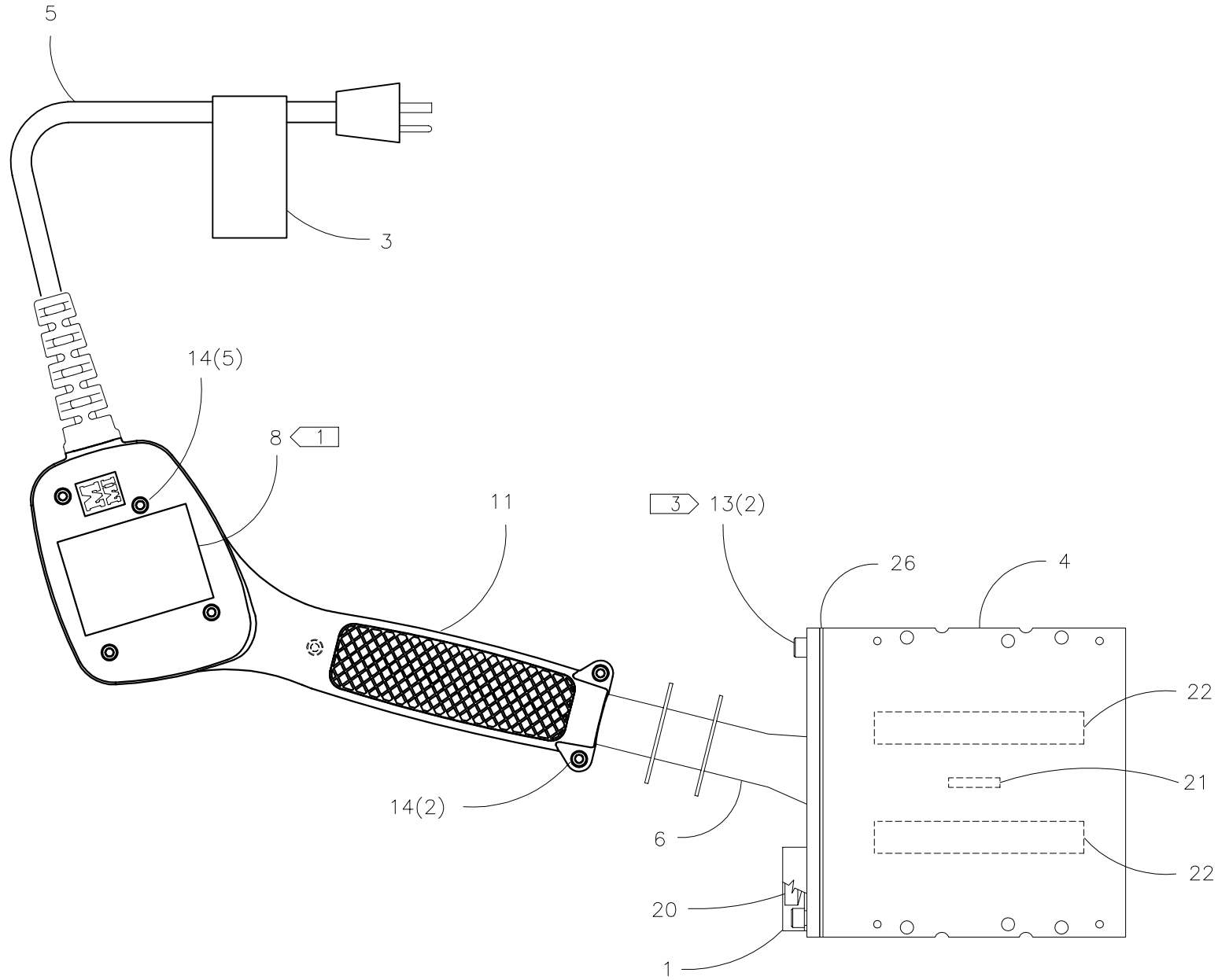

McElroy Manufacturing, Inc.
 The leader by design.
 Tulsa, Oklahoma U.S.A.

DRAWN: RLE	CHECK: TMT	APPRV'D: JRP	DATE: 3/25/02	DWG No: 424300	SHT No: 11A	REV No: C	PART No: 424311
#14 Multi-Mc SIDEWALL & SOCKET HEATER ASSEMBLY 100-120V, 50/60Hz, 1Ph							CAD No: 424311

NOTE: THIS DRAWING AND THE INFORMATION CONTAINED THEREIN IS THE CONFIDENTIAL AND PROPRIETARY PROPERTY OF McElroy Manufacturing, Inc. THE DRAWING IS NOT TO BE REPRODUCED IN ANY MANNER, SUBMITTED OUTSIDE PARTIES FOR EXAMINATION, OR USED DIRECTLY OR INDIRECTLY FOR THE PURPOSES OTHER THAN THOSE FOR WHICH IT WAS FURNISHED WITHOUT WRITTEN PERMISSION OF McElroy Manufacturing, Inc.





NOTE: THIS DRAWING AND THE INFORMATION CONTAINED THEREIN IS THE CONFIDENTIAL AND PROPRIETARY PROPERTY OF McElroy Manufacturing, Inc. THE DRAWING IS NOT TO BE REPRODUCED IN ANY MANNER, SUBMITTED OUTSIDE PARTIES FOR EXAMINATION, OR USED DIRECTLY OR INDIRECTLY FOR THE PURPOSES OTHER THAN THOSE FOR WHICH IT WAS FURNISHED WITHOUT WRITTEN PERMISSION OF McElroy Manufacturing, Inc.

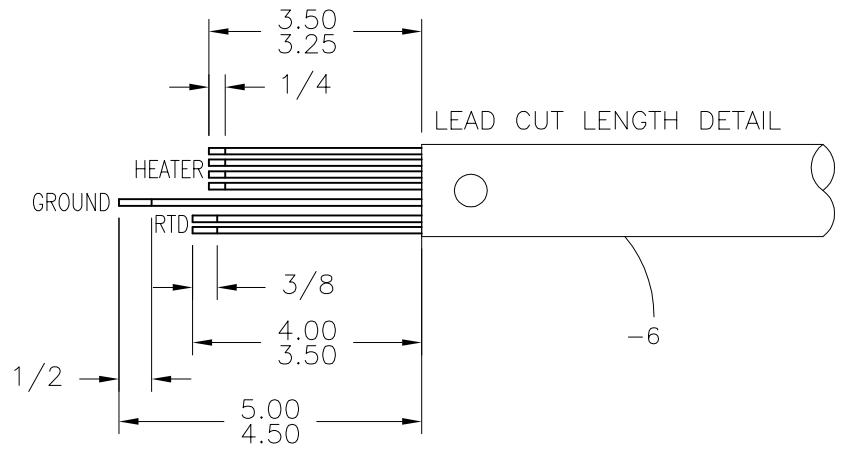
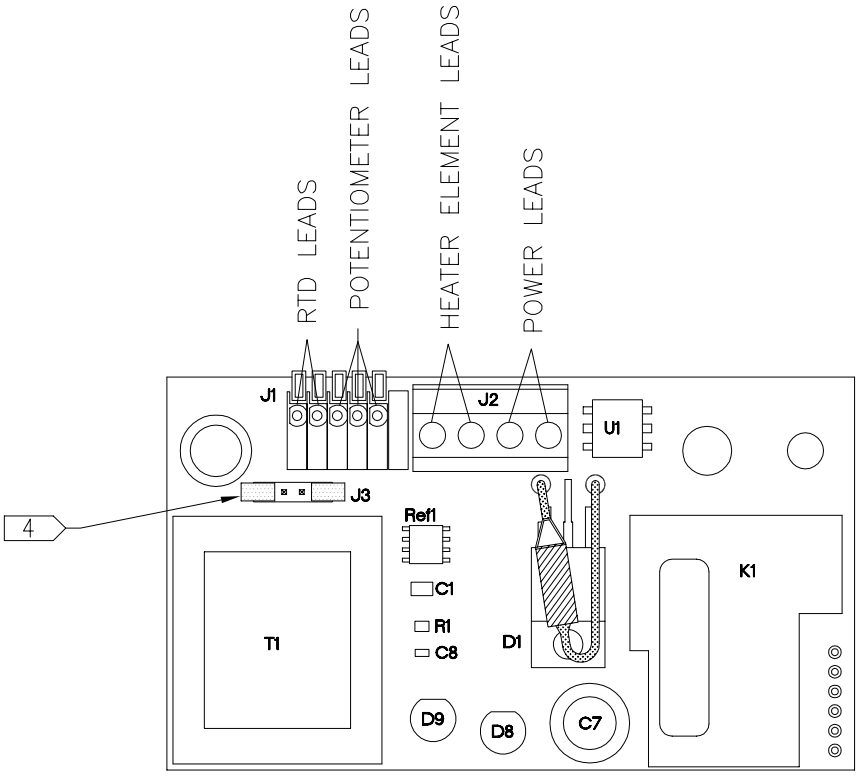
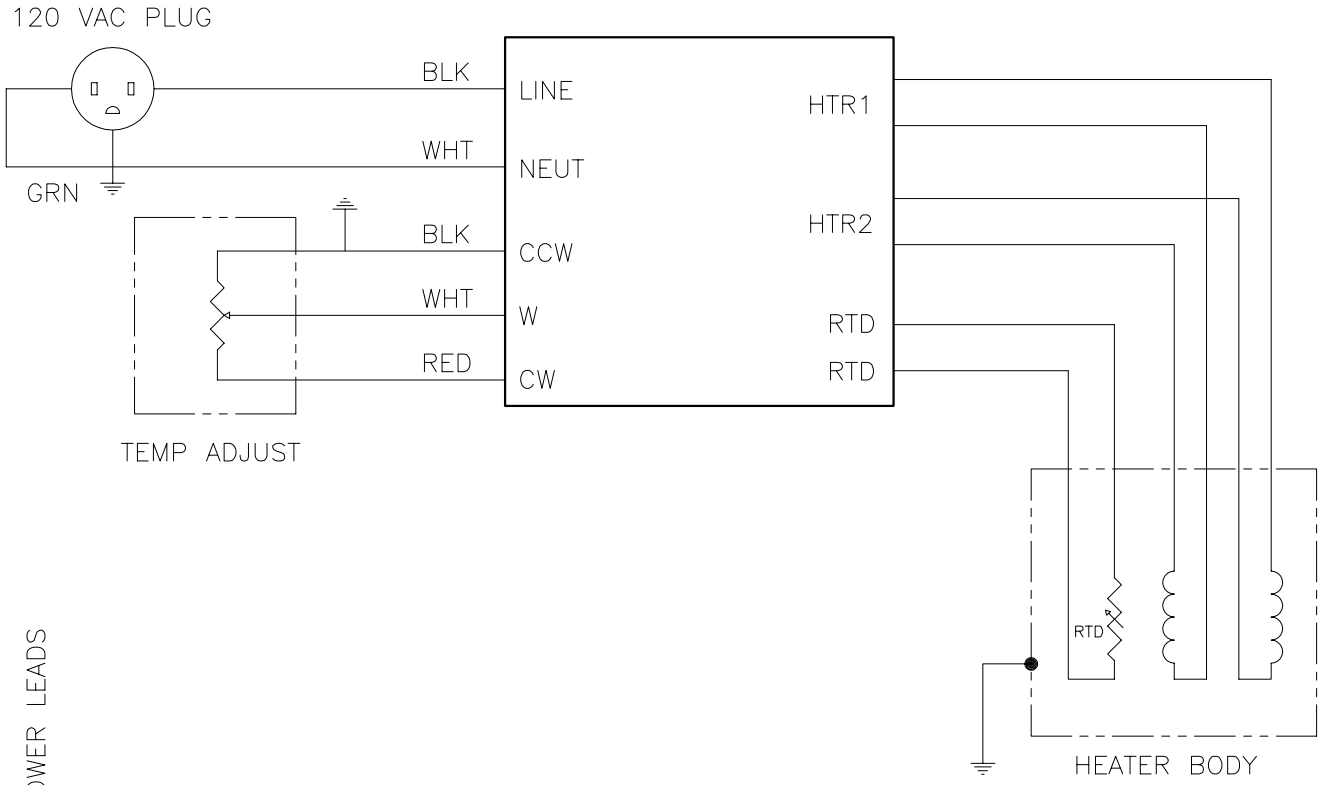

DETAIL ITEM -9 REF.



McElroy Manufacturing, Inc.
 The leader by design.
 Tulsa, Oklahoma U.S.A.

DRAWN: RLE	CHECK: TMT	APPRV'D: JRP	DATE: 3/25/02	DWG No: 424300	SHT No: 11C	REV No: C	PART No: 424311
#14 Multi-Mc SIDEWALL & SOCKET HEATER ASSEMBLY 100-120V, 50/60Hz, 1Ph							CAD No: 424311

NOTE: THIS DRAWING AND THE INFORMATION CONTAINED THEREIN IS THE CONFIDENTIAL AND PROPRIETARY PROPERTY OF McElroy Manufacturing, Inc. THE DRAWING IS NOT TO BE REPRODUCED IN ANY MANNER, SUBMITTED OUTSIDE PARTIES FOR EXAMINATION, OR USED DIRECTLY OR INDIRECTLY FOR THE PURPOSES OTHER THAN THOSE FOR WHICH IT WAS FURNISHED WITHOUT WRITTEN PERMISSION OF McElroy Manufacturing, Inc.

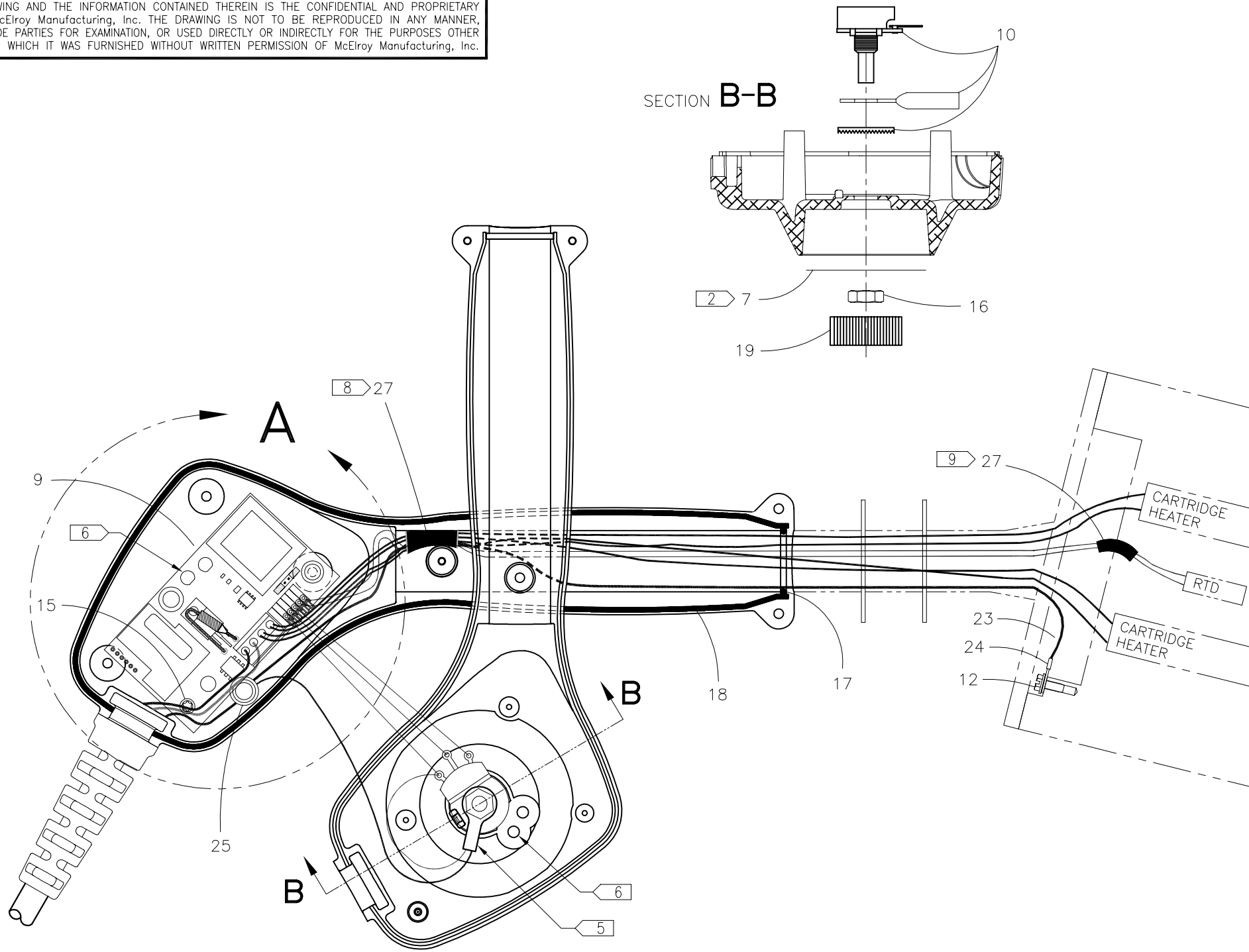



McElroy Manufacturing, Inc.
The leader by design.
Tulsa, Oklahoma U.S.A.

DRAWN: RLE	CHECK: TMT	APPRV'D: JRP	DATE: 3/25/02	DWG No: 424300	SHT No: 11D	REV No: C	PART No: 424311
#14 Multi-Mc SIDEWALL & SOCKET HEATER ASSEMBLY 100-120V, 50/60Hz, 1Ph							CAD No: 424311

NOTE: THIS DRAWING AND THE INFORMATION CONTAINED THEREIN IS THE CONFIDENTIAL AND PROPRIETARY PROPERTY OF McElroy Manufacturing, Inc. THE DRAWING IS NOT TO BE REPRODUCED IN ANY MANNER, SUBMITTED OUTSIDE PARTIES FOR EXAMINATION, OR USED DIRECTLY OR INDIRECTLY FOR THE PURPOSES OTHER THAN THOSE FOR WHICH IT WAS FURNISHED WITHOUT WRITTEN PERMISSION OF McElroy Manufacturing, Inc.

DETAIL TO SHOW HOW TO LAY WIRES INTO ENCLOSURE

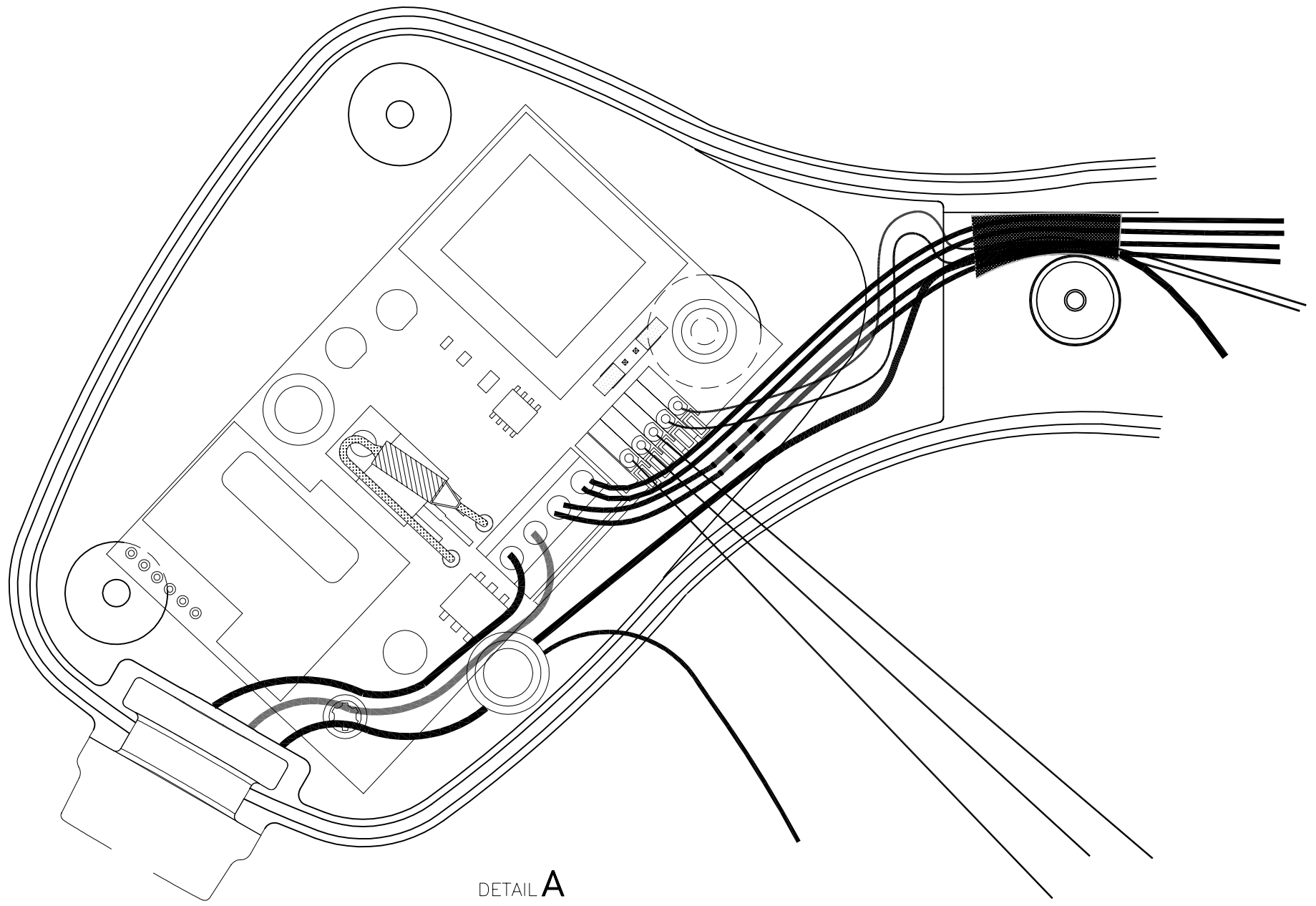

DETAIL A

**#14 Multi-Mc SIDEWALL & SOCKET HEATER ASSEMBLY
100-120V, 50/60Hz, 1Ph**

Parts List

ITEM	PART NO.	QTY.	DESCRIPTION
	424311		ASSEMBLY
1	214801	1	Multi-Mc THERMAL GUARD
2	A424901	1	4" Multi-Mc HEATER SCREW & DRIVER KIT (NOT SHOWN)
3	410906	1	DANGER NOT EXPLOSION PROOF TAG LABEL
4	424402	1	HEATER BODY
5	434201	1	13AMP/120V POWER CORD
6	436001	1	HEATER COVER PLATE WELDMENT
7	816382	1	TEMPERATURE SCALE LABEL
8	816389	1	MODEL 424311 PART NO. LABEL
9	T5030001	1	HEATER CONTROL PCB ASSEMBLY
10	T5030002	1	POTENTIOMETER ASSEMBLY
11	T5030103	1	HEATER HANDLE/ENCLOSURE
12	MAH00036	1	#6-32NC x 3/8 LG. HWH TC SCREW
13	MAH00052	2	1/4-20NC x 3/4 LG. SHCS SS
14	MAL00010	7	#6-19 x 3/4 LG. TORX T15 PAN HEAD SCREW
15	MAL00011	1	#6-19 x 1/4 LG. TORX T15 PAN HEAD SCREW
16	MBA00067	1	HEX SEAL NUT
17	MDL00018	1	O-RING
18	MDL00243	26IN	.070 DIA. BUNA-N O-RING STOCK
19	MJJ00023	1	CONTROL KNOB
20	MJK00001	1	5" LG., 150-750° F THERMOMETER
21	MKI00003	1	1 x 3/16 316SS 100 OHM PLATINUM RTD
22	MLD00011	2	120V, 600W, 5/8 x 4 CARTRIDGE HEATER
23	MLL00004	18IN	#18 TYPE TGGT ELECTRICAL WIRE
24	MLM00004	1	RING TERMINAL
25	MLM00010	1	CONNECTOR
26	436301	1	COVER PLATE GASKET
27	MLN00219	8IN	FIBERGLASS TAPE

NOTES:

- ITEM 8 SHOULD BE ORIENTED THE SAME AS THE MMI LOGO.
- ITEM 7 MUST BE ORIENTED SO THE NOTCH ENGAGES THE KEY ON ITEM 11.
- INSTALL WITH HIGH TEMPERATURE ANTI-SEIZE COMPOUND.
- PLACE TWO JUMPERS AS SHOWN FOR 100-120V OPERATION.
- RING TERMINAL MUST BE ORIENTED AS SHOWN.
- WHEN MATING HALVES, MAKE SURE THE LED ON THE PC BOARD, ITEM 9, FITS INTO LONG SOCKET ON COVER.

#14 Multi-Mc SIDEWALL & SOCKET HEATER ASSEMBLY
100-120V, 50/60Hz, 1Ph

Parts List

ITEM	PART NO.	QTY.	DESCRIPTION
7.			SET AND CHECK TEMPERATURE PER SP-9.
8.			TAPE WIRES IN AREA OF HANDLE BOSS TO PREVENT PINCHING AT ASSEMBLY.
9.			TAPE RTD WIRES IN AREA OF RTD HOLE EXIT TO PREVENT CHAFFING.

DRAWING REVISION HISTORY LISTING

PART NO: 424311

DESCRIPTION: #14 Multi-Mc SIDEWALL & SOCKET HEATER ASSEMBLY 100-120V, 50/60Hz, 1Ph

<u>APPR.</u>	<u>REV</u>	<u>DATE</u>	<u>BY</u>	<u>DESCRIPTION OF REVISION</u>
SWB	A	01/23/03	BWW	ADDED ITEM 27 MLN00219 WITH A QTY OF 8IN & ADDED NOTE 8 AND 9 FOR TAPING WIRES. ADDED LENGTH TOLERANCE TO LEAD CUT LENGTH DETAIL.
SWB	B	8/15/03	RLE	REVISED STRIP LENGTH ON RTD ONLY FROM 3/16 TO 3/8 TO MAKE COMPATIBLE WITH CONNECTOR USED ON REV. 'B' HEATER CONTROL PCB ASSEMBLY (T5030001) & UPDATED PICTURE OF HEATER CONTROL PCB ASSEMBLY.
SWB	C	10/27/03	BWW	CORRECTED PICTORIALY THE VIEW OF THE PCB BOARD ON SHT 11C AND 11D TO SHOW CURRENT DESIGN.