

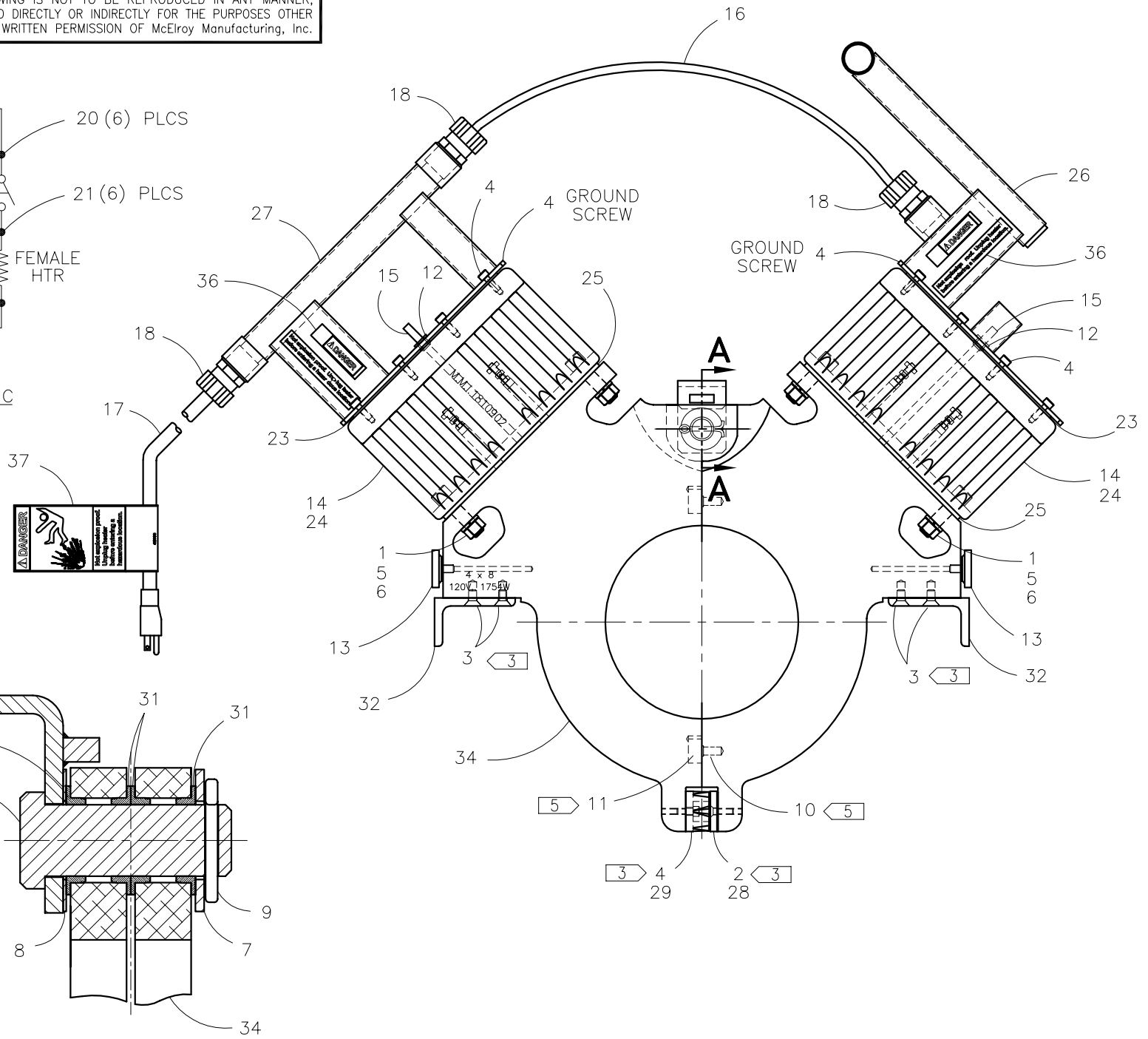

McElroy Manufacturing, Inc.
 The leader by design.
 Tulsa, Oklahoma U.S.A.

DRAWN: SS	CHECK: BWP	APPRVD: JRP	DATE: 7/23/97	DWG No: 829900	SHT No: 1	REV No: C	PART No: 829901
4 x 8 SPLIT HEATER ASSEMBLY 120V, 50/60Hz, 1Ph							CAD No: 829901

NOTE: THIS DRAWING AND THE INFORMATION CONTAINED THEREIN IS THE CONFIDENTIAL AND PROPRIETARY PROPERTY OF McElroy Manufacturing, Inc. THE DRAWING IS NOT TO BE REPRODUCED IN ANY MANNER, SUBMITTED OUTSIDE PARTIES FOR EXAMINATION, OR USED DIRECTLY OR INDIRECTLY FOR THE PURPOSES OTHER THAN THOSE FOR WHICH IT WAS FURNISHED WITHOUT WRITTEN PERMISSION OF McElroy Manufacturing, Inc.

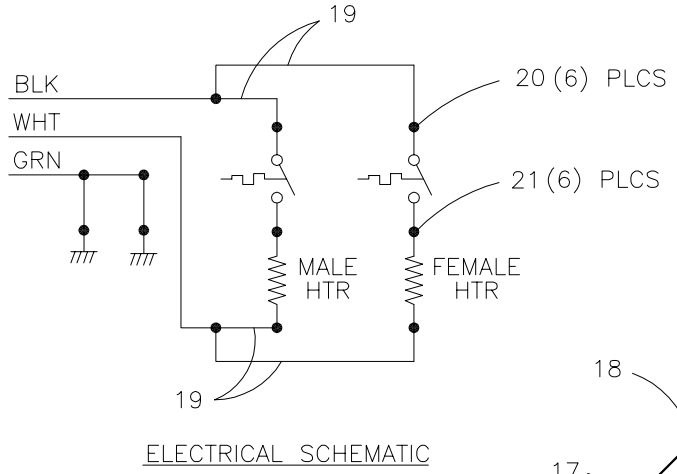

SECTION **A-A**

4 x 8 SPLIT HEATER ASSEMBLY
120V, 50/60Hz, 1Ph

Parts List

ITEM	PART NO.	QTY.	DESCRIPTION
	829901	1	ASSEMBLY
1	MAH00078	4	3/8-16NC x 1-1/2 LG. SHCS SS
2	MAH00105	1	#10-24NC x 3/4 LG. FHSCS SS
3	MAN00014	4	1/4-20NC x 1/2 LG. FHSCS SS
4	MAH00046	19	#10-24 x 1/2 LG. SHCS SS
5	MBA00007	4	3/8-16NC FINISHED HEX NUT
6	MBE00007	4	3/8" REGULAR SPLIT LOCK WASHER
7	MBG00004	1	3/4" TYPE 'AN' FLAT WASHER
8	MBG00006	1	3/4" TYPE 'AN' FLAT WASHER
9	MCH00001	1	1/8" DIA. x 1" LG. COTTER PIN
10	MCK00025	2	1/4" DIA. BULLET NOSE DOWEL (REF.)
11	MCK00026	2	1/4" I.D. SLOTTED LOCATOR BUSHING (REF.)
12	MDL00071	2	GROMMET
13	MJK00002	2	150-750° F THERMOMETER
14	MJQ00125	4	1/16" x 3.3" x 6.63" GASKET
15	MLC00006	2	THERMOSWITCH
16	MLE00003	1 FT	#14/3 ELECTRICAL CABLE
17	MLE00010	1	#14/3 ELECTRICAL CABLE ASSEMBLY
18	MLK00007	3	STRAIN RELIEF CONNECTOR
19	MLL00020	4 FT	#14 TYPE TGGT WIRE
20	MLM00010	6	CONNECTOR
21	MLM00013	6	CONNECTOR
22			
23	1808102	2	HEATER GASKET
24	1810902	2	TERMINAL ENCLOSURE
25	1207302	2	TERMINAL ENCLOSURE GASKET
26	1237601	1	MALE SPLIT HEATER HANDLE BRACKET WELDMENT
27	1237701	1	FEMALE SPLIT HEATER HANDLE BRACKET WELDMENT
28	1238001	1	SPLIT HEATER MAGNETIC CATCH
29	1238002	1	SPLIT HEATER MAGNET MODIFICATION
30	1238101	1	SPLIT HEATER PIVOT PIN
31	1238301	4	SPLIT HEATER PIVOT BUSHING
32	1238501	2	SPLIT HEATER MOUNTING BRACKET
33	1238503	1	SPLIT HEATER STRIPPER BAR WELDMENT
34	A829913	1	4 X 8 SPLIT HEATER BODY SET
35			

4 x 8 SPLIT HEATER ASSEMBLY
120V, 50/60Hz, 1Ph

Parts List

ITEM	PART NO.	QTY.	DESCRIPTION
36	410903	4	DANGER NOT EXPLOSION PROOF LABEL
37	410906	1	DANGER NOT EXPLOSION PROOF TAG LABEL
38	223901	1	HEATER TAG
39	1243801	1	SPLIT HEATER OPERATOR'S MANUAL

NOTES:

1. ITEMS 38 & 39 NOT SHOWN.
2. SET AND CHECK TEMPERATURE PER SP-9.
3. INSTALL WITH HIGH TEMPERATURE ANTI-SEIZE COMPOUND
4. ITEMS 7 & 8 ARE USED AS REQUIRED; QUANTITIES MAY VARY DUE TO TOLERANCE STACK.
5. ITEMS 10 & 11 ARE INCLUDED AS PART OF #A829913 4 x 8 SPLIT HEATER BODYSET.

DRAWING REVISION HISTORY LISTING

PART NO: 829901

DESCRIPTION: 4 x 8 SPLIT HEATER ASSEMBLY 120V, 50/60Hz, 1Ph

<u>APPR.</u>	<u>REV</u>	<u>DATE</u>	<u>BY</u>	<u>DESCRIPTION OF REVISION</u>
TLW	A	07/28/98	MRP	ADDED NOTES #5 & #6
SWB	B	4/9/02	RLE	REMOVED ITEM 35 & REVISED ITEM 34 TO A829913 SPLIT HEATER BODY SET WHICH CONTAINS BOTH MALE & FEMALE BODIES. THIS WAS NECESSARY SINCE BODIES ARE MANUFACTURED AS MATCHED SETS. REVISED NOTES 5 & 6 ACCORDINGLY & CONSOLIDATED INTO ONE NOTE.
SWB	C	08/26/02	BWW	CORRECTED BY REMOVING ITEM NUMBER 22 FROM FACE OF DRAWING.