

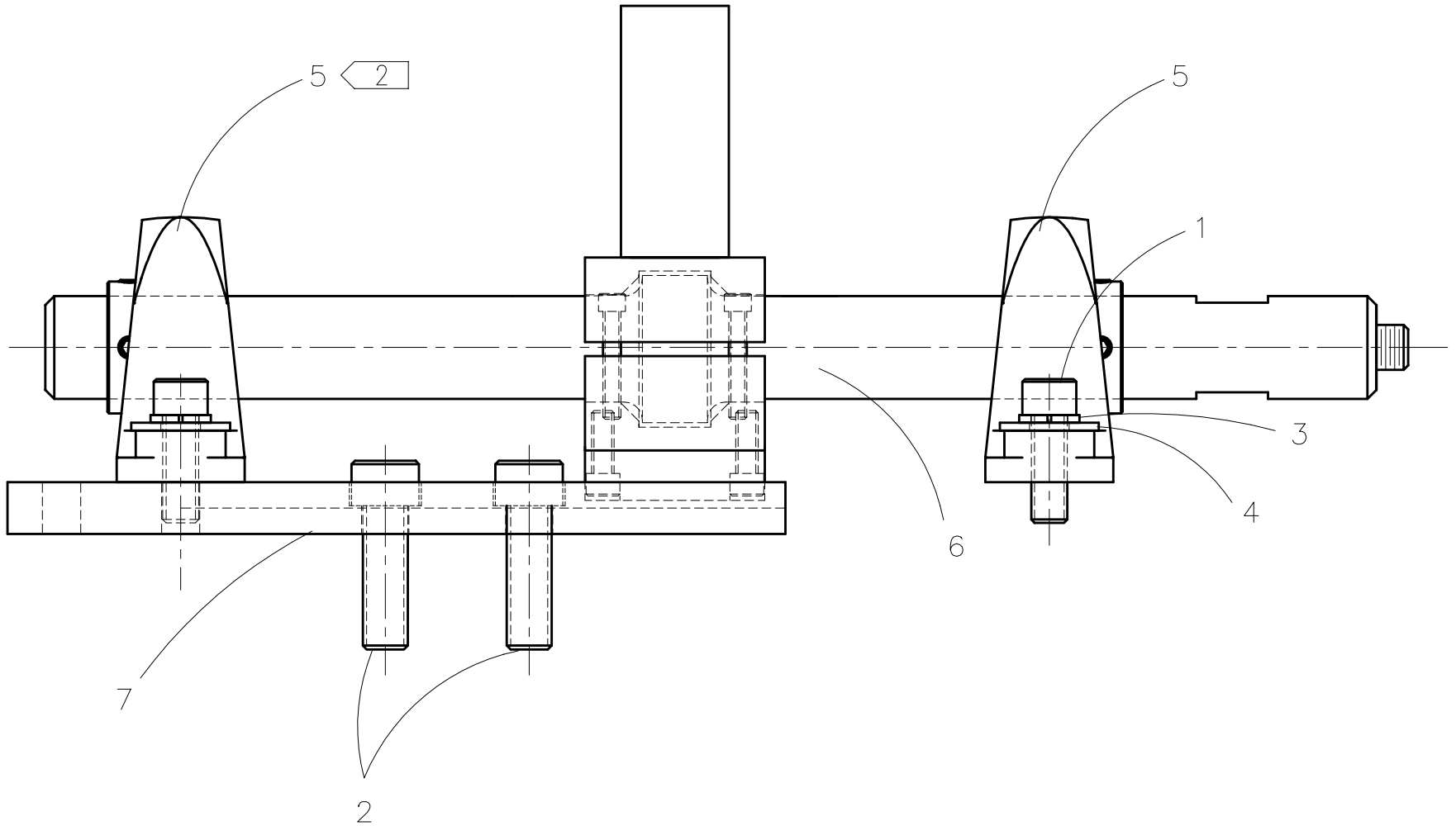

McElroy Manufacturing, Inc.
The leader by design.
Tulsa, Oklahoma U.S.A.

DRAWN: CED	CHECK: BWP	APPRV'D: RAD	DATE: 5/19/98	DWG No: S01000	SHT No: 1	REV No: A	PART No: S01001
SIDEWALL FUSION TESTING FIXTURE							CAD No: S01001

NOTE: THIS DRAWING AND THE INFORMATION CONTAINED THEREIN IS THE CONFIDENTIAL AND PROPRIETARY PROPERTY OF McElroy Manufacturing, Inc. THE DRAWING IS NOT TO BE REPRODUCED IN ANY MANNER, SUBMITTED OUTSIDE PARTIES FOR EXAMINATION, OR USED DIRECTLY OR INDIRECTLY FOR THE PURPOSES OTHER THAN THOSE FOR WHICH IT WAS FURNISHED WITHOUT WRITTEN PERMISSION OF McElroy Manufacturing, Inc.



McSNAPPER™ SIDEWALL FUSION TESTING FIXTUREParts List

ITEM	PART NO.	QTY.	DESCRIPTION
	S01001		ASSEMBLY
1	MAC00141	4	1/2-13NC X 1-1/2"LG SHCS STL BL
2	MAC00165	2	5/8-11NC X 2"LG SHCS STL BL
3	MBE00009	4	1/2" REG SPLIT LK WASHER STL PL.
4	MBF00009	4	1/2" TYPE 'A' WIDE FLT WASHER STL PL
5	MDM00285	2	PILLOW BLOCK BEARING
6	S01101	1	SHAFT HAMMER ASSEMBLY
7	S01108	1	SIDEWALL EXTENSION PLATE
8	S0100101	1	INSTRUCTION SHEET

NOTES:

1. INSTRUCTION SHEET ITEM #8 NOT SHOWN.
2. REMOVE SET SCREWS ON ITEM #5 AND INSTALL WITH EXTENDED BEARING SIDE FACING AWAY FROM 5/8" HOLES.

DRAWING REVISION HISTORY LISTING

PART NO: S01001

DESCRIPTION: SIDEWALL FUSION TESTING FIXTURE

<u>APPR.</u>	<u>REV</u>	<u>DATE</u>	<u>BY</u>	<u>DESCRIPTION OF REVISION</u>
CED	A	05/11/99	AH	CHANGED ITEM #2(MAC00165) QTY OF (4) TO QTY. OF (2). ADDED NOTE #2.