



McElroy Manufacturing, Inc.
 The leader by design.
 Tulsa, Oklahoma U.S.A.

DRAWN: TGW	CHECK: TLW	APPRV'D: SWB	DATE: 11/18/98	DWG No.: 220000	SHT No.: 7	REV No.: B	PART No.: TABULATED
2" HOT TAPPING TOOL ASSEMBLIES							CAD No.: 220000

NOTE: THIS DRAWING AND THE INFORMATION CONTAINED THEREIN IS THE CONFIDENTIAL AND PROPRIETARY PROPERTY OF McElroy Manufacturing, Inc. THE DRAWING IS NOT TO BE REPRODUCED IN ANY MANNER, SUBMITTED TO OUTSIDE PARTIES FOR EXAMINATION, OR USED DIRECTLY OR INDIRECTLY FOR THE PURPOSES OTHER THAN THOSE FOR WHICH IT WAS FURNISHED WITHOUT WRITTEN PERMISSION OF McElroy Manufacturing, Inc.

ASSY NO.	DESCRIPTION	ITEM #1
220002	MED. DENSITY 2406 HTT ASSY	22120302
220003	HIGH DENSITY 3408 HTT ASSY	22120303
220006	DRISCOPIPE-8100 HTT ASSY	22120306

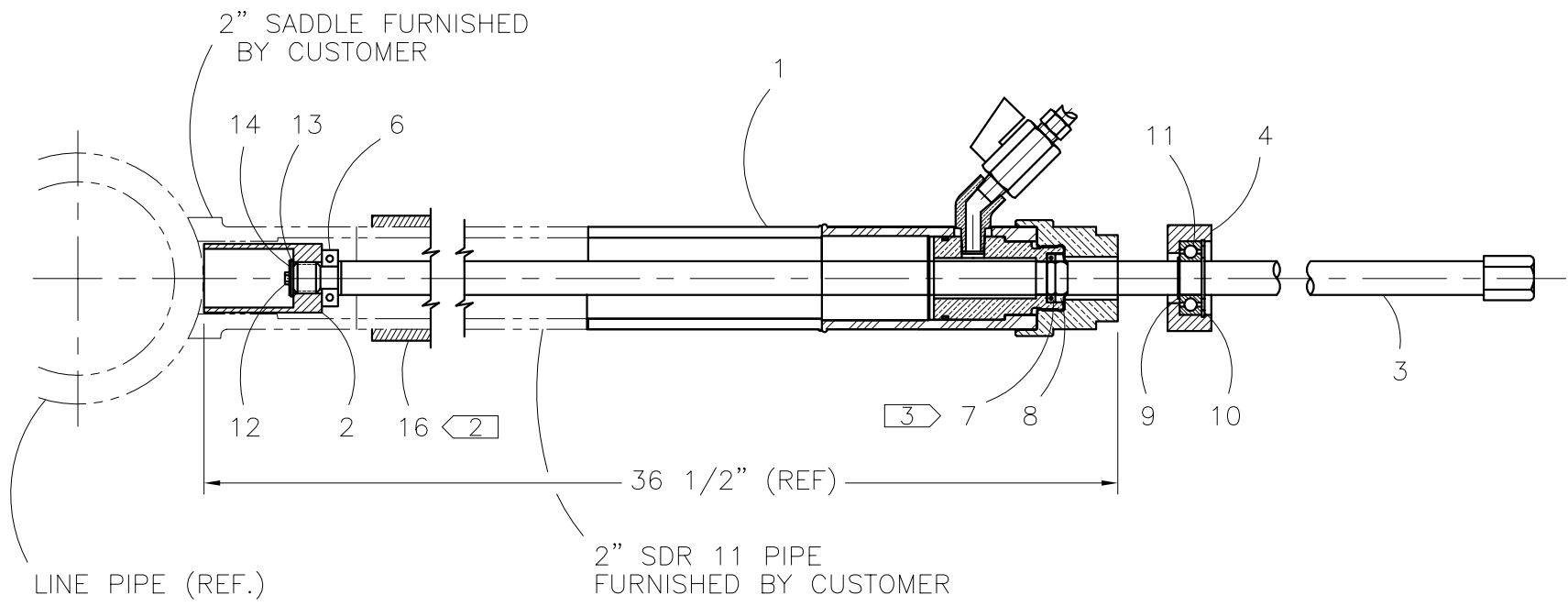

2" HOT TAPPING TOOL ASSEMBLIESPARTS LIST

ITEM	PART NO.	QTY	DESCRIPTION
	TABULATED		ASSEMBLY
1	TABULATED	1	GLAND FITTING ASSEMBLY
2	221501	1	TOOTHED CUTTER
3	221301	1	SHAFT
4	220701	1	BEARING HOUSING
5	220501	1	STORAGE BOX
6	MJQ00056	1	CLAMP COLLAR
7	MDL00023		SEAL
8	MDL00024		WIPER
9	MCB00003	2	EXT SNAP RING
10	MCA00007	1	INT SNAP RING
11	MDM00028	1	BALL BEARING
12	MAH00091	1	1/4-20NC x 1/2" LG HHCS W/ NYLON LOCK
13	MBG00025	1	3/8" THRUST WASHER
14	MBF00005	1	1/4" TYPE 'A' WIDE FLAT WASHER
15	MJL00004	1	7/8 & 3/4 RATCHET BOX WRENCH
16	220801	1	SLEEVE

NOTES:

1. ITEMS #5 AND #15 ARE NOT SHOWN.
2. ITEM #16 IS OPTIONAL.
3. ITEMS #7 AND #8 ARE PART OF ITEM #1 (GLAND FITTING ASSEMBLY).

DRAWING REVISION HISTORY LISTING

PART NO: 220000
DESCRIPTION: 2" HOT TAPPING TOOL ASSEMBLIES

<u>APPR.</u>	<u>REV</u>	<u>DATE</u>	<u>BY</u>	<u>DESCRIPTION OF REVISION</u>
SWB	---	11/18/98	TGW	COMBINED ALL 2" HOT TAPPING TOOL ASSEMBLIES ONTO SHEET 7. DELETED ASSEMBLY #'s 220001 & 220004. ADDED ASSEMBLY #'s 220007 THRU 220009.
SWB	A	2/11/02	ALK	UPDATED VIEW TO MATCH 225007 GLAND FITTING SUB-ASSEMBLY ON 5/29/01
SWB	B	12/04/06	PJD	REVISED DRS6500 TO MED. DENSITY 2406, PLX3408 TO HIGH DENSITY 3408, AND DRS8100 TO DRISCOPIPE-8100 AND DELETED ASSY NO.: 220007, 220008, AND 220009 TO CONSOLIDATE LIKE MATERIAL TYPE.