



McElroy Manufacturing, Inc.
 The leader by design.
 Tulsa, Oklahoma U.S.A.

DRAWN: DOUG	CHECK: BWP	APPRV'D: B	DATE: 6/5/91	DWG No: CTS00700	SHT No: 3	REV No: D	PART No: CTS00703
1" Mini-Mc HEATER ASSEMBLY 200-240V, 50/60Hz, 1Ph							CAD No: CTS00703

NOTE: THIS DRAWING AND THE INFORMATION CONTAINED THEREIN IS THE CONFIDENTIAL AND PROPRIETARY PROPERTY OF McElroy Manufacturing, Inc. THE DRAWING IS NOT TO BE REPRODUCED IN ANY MANNER, SUBMITTED OUTSIDE PARTIES FOR EXAMINATION, OR USED DIRECTLY OR INDIRECTLY FOR THE PURPOSES OTHER THAN THOSE FOR WHICH IT WAS FURNISHED WITHOUT WRITTEN PERMISSION OF McElroy Manufacturing, Inc.

NOTES:

1. USE SLEEVING (ITEM 17) TO COVER EXPOSED WIRING.
2. SPLICE LEADS IN HADLE.

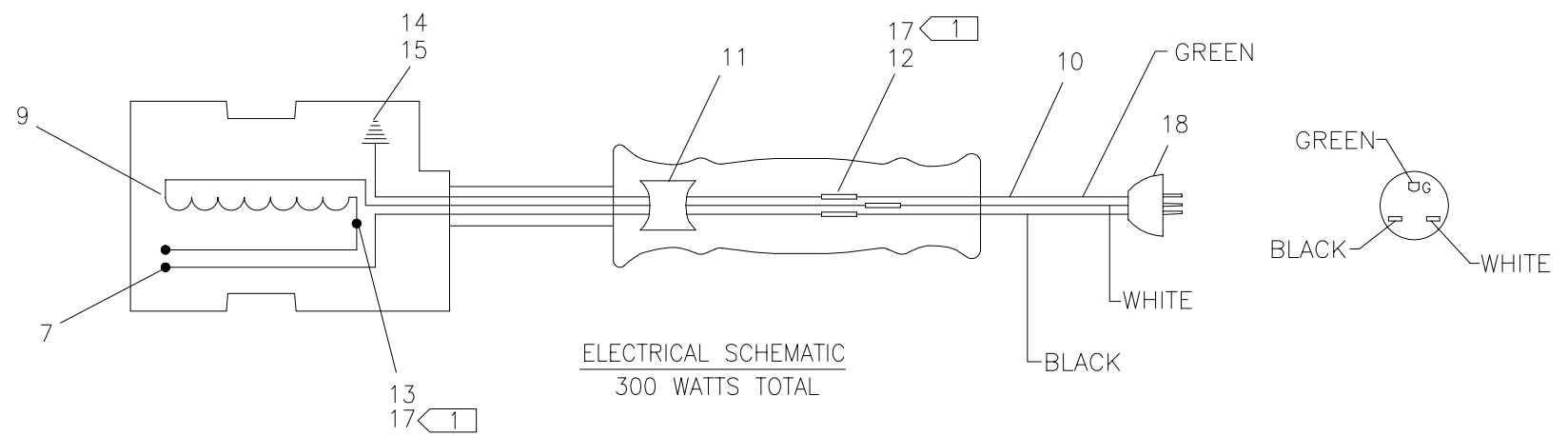
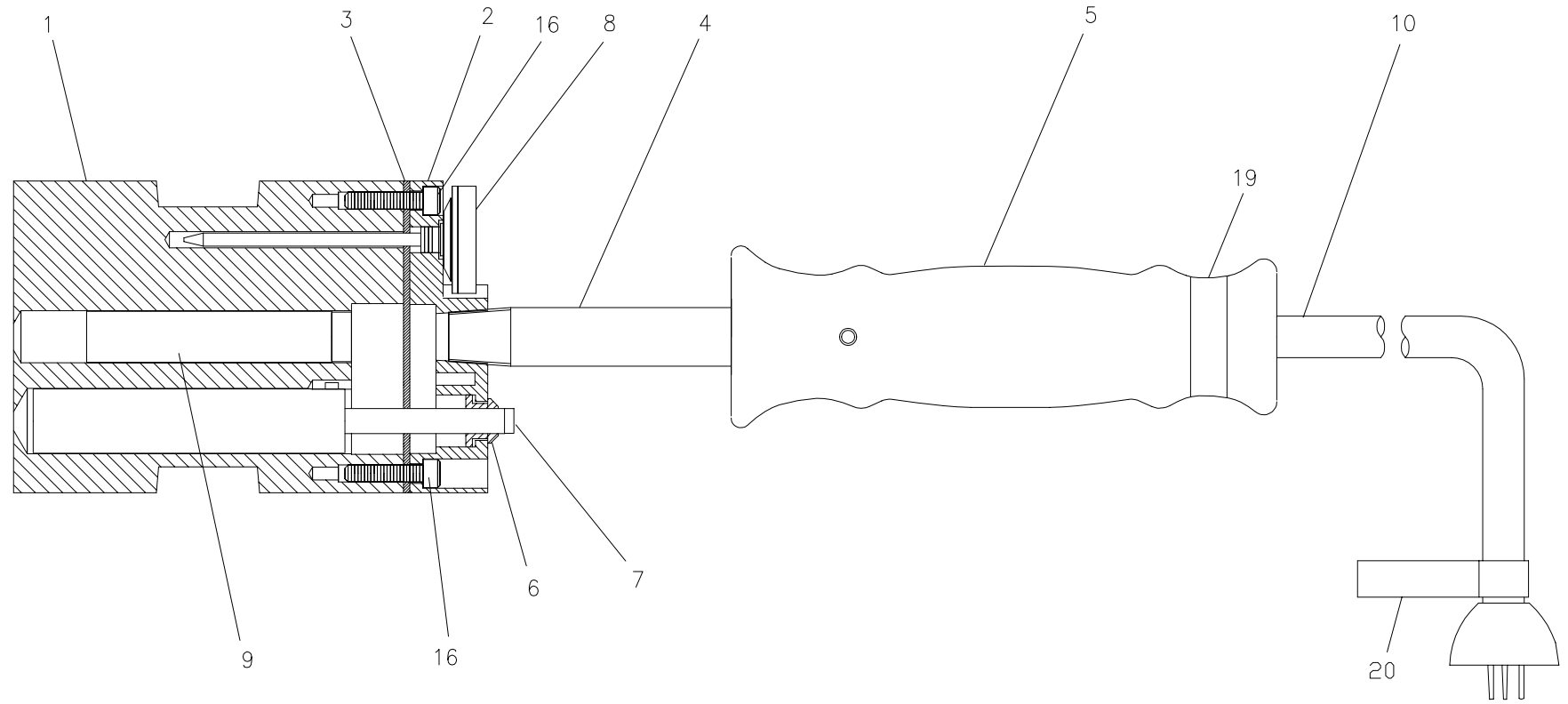

**1" IPS Mini-Mc HEATER ASSEMBLY
200-240V, 50/60Hz, 1 Ph**

PARTS LIST

ITEM	PART NO.	QTY	DESCRIPTION
	CTS00703		Assembly
1	CTS01002	1	Heater Body
2	CTS01102	1	Cover Plate
3	CTS01201	1	Gasket
4	206101	1	Nipple
5	409801	1	Handle Modification
6	215601	1	Grommet
7	MLC00010	1	Thermoswitch
8	MJK00002	1	Thermometer
9	MLD00021	1	Cartridge Heater
10	MLE00034	20FT	#16/3 Electrical Cable
11	MLN00010	1	5/16" Strain Relief Clamp
12	MLM00003	3	Insulated Butt Splice
13	MJQ00046	1	Ferrule
14	MLM00004	1	Ring Terminal
15	MAH00036	1	#6-32 NC x 3/8" Lg. HHWF Type 'F' SET SCREW
16	MAH00042	4	#8-32 NC x 1/2" Lg. SHCS SS
17	MLW00002	.25FT	Fiberglass Sleeving
18	MLF00007	1	Electrical Plug
19	816361	1	Model CTS00703 Part No. Label
20	410906	1	Danger Not Explosion Proof Tag Label

DRAWING REVISION HISTORY LISTING

PART NO: CTS00703
DESCRIPTION: 1" Mini-Mc HEATER ASSEMBLY 200-240V, 50/60Hz, 1Ph

<u>APPR.</u>	<u>REV</u>	<u>DATE</u>	<u>BY</u>	<u>DESCRIPTION OF REVISION</u>
B	B	6/15/95	SWB	Reduced to 'A' size in Bravo. Replaced #MAH00041 w/ #MAH00042. Replaced #MLN00219 w/ #MLW00002. Created typed parts list.
SWB	C	1/20/97	DJL	CHANGE 220-240V TO 200-240V. RE-NUMBER DRAWING AND BOM TO CLEAN UP. ADDED ITEM 19(P/N 816361) LABEL TO SPECIFY VOLTAGE AND WATTS. ADDED ITEM 20(P/N410906) EXPLOSION PROOF LABEL AT PLUG END OF POWER CORD. ADDED PLUG WIRE LOCATIONS FOR ITEM 18. REMOVED NOTE 3 FOR RESTAMPING BODY FOR 220V.
TLW	-	12/12/97	JPS	CHANGED ITEM #17 FROM 8" TO 4".
SWB	D	11/09/05	BWW	MOVED NOTES TO FACE OF DRAWING FOR CLARITY.