



McElroy Manufacturing, Inc.
 The leader by design.
 Tulsa, Oklahoma U.S.A.

DRAWN: TLW

CHECK: doug

APPRV'D: B

DATE: 5/13/96

DWG No: B3-2800

SHT No: 1

REV No: E

PART No: B3-2801

3" JIS Bullet ASSEMBLY

CAD FILE No: B3-2801

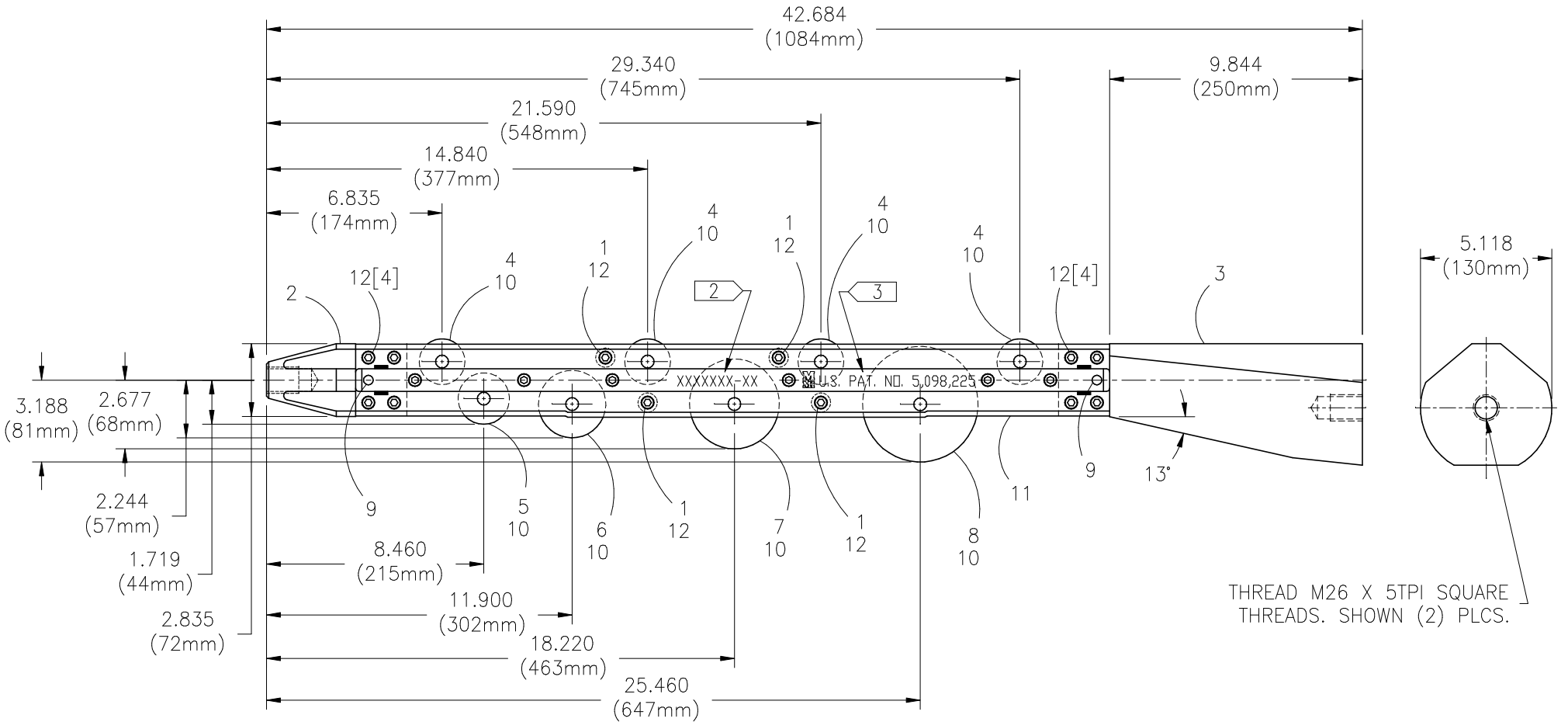
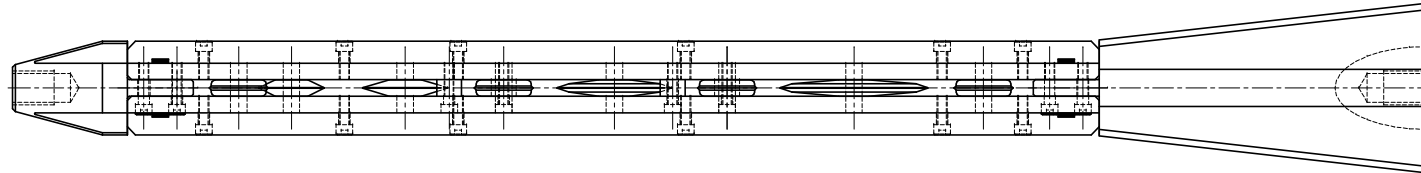

NOTE:

DIMENSIONS IN () ARE IN MILLIMETERS. ALL OTHER DIMENSIONS ARE IN INCHES.

APPROVED AS DRAWN _____ DATE _____

REVISED AS NOTED _____ DATE _____

NOTE: This drawing and the information contained therein is the confidential and proprietary property of McElroy Manufacturing, Inc. The drawing is not to be reproduced in any manner, submitted to outside parties for examination, or used directly or indirectly for purposes other than those for which it was furnished without written permission of McElroy Manufacturing, Inc.

3" JIS Bullet™ ASSEMBLYParts List

ITEM	PART NO.	QTY.	DESCRIPTION
	B3-2801	1	ASSEMBLY
1	B3-1401	4	SPLITTER BODY SPACER
2	B3-2901	1	NOSE CONE (JAPAN)
3	B3-3101	1	75MM EXPANDER (JAPAN)
4	B3-401	4	GUIDE ROLLER
5	B3-901	1	CUTTER WHEEL-2" DIA.
6	B3-902	1	CUTTER WHEEL-2-5/8" DIA.
7	B3-903	1	CUTTER WHEEL 3-1/2" DIA.
8	B3-904	1	CUTTER WHEEL- 4-1/2" DIA.
9	MCI00005	2	3/8" DIA X 2-3/4"LG DOWEL PIN
10	MCI00014	8	1/2" DIA X 1-1/2"LG DOWEL PIN
11	B3-3501	1	3" SPLITTER BODY SET (JAPAN)
12	MAC00076	12	5/16-18NC X 1-1/4"LG SHCS STL BL

NOTES:

1. STAMP SERIAL NUMBER ON FLAT AS SHOWN.
MMI JOB NO. XXXXXXXX-XX 01, 01, ECT.
(TYP. N.S. & F.S.)
2. STAMP MMI LOGO & U.S. PATENT NUMBER 5,098,225 ON FLAT AS SHOWN. (TYP. N.S. & F.S.)