



McElroy Manufacturing, Inc.
The leader by design.
Tulsa, Oklahoma U.S.A.

DRAWN: TLW

CHECK:

APPRV'D:

DATE: 02-05-96

DWG No: B2-200

SHT No: 2

REV No: A

PART No: B2-202

2" BULLET ASSEMBLY

CAD FILE No: B2-202

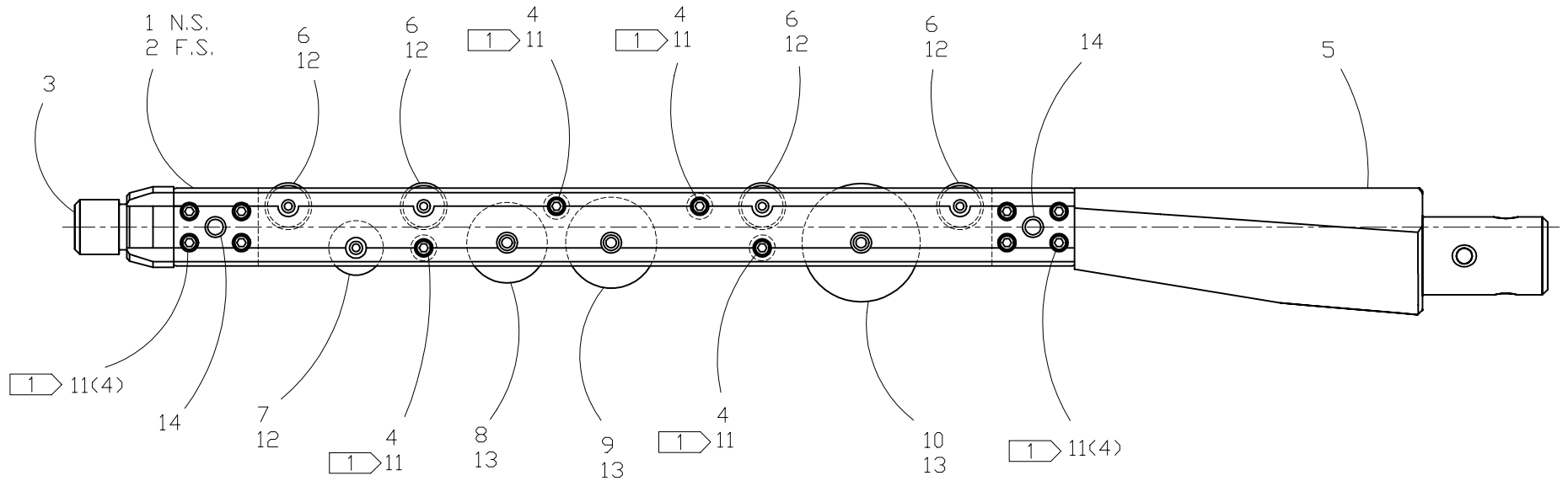

NOTE: This drawing and the information contained therein is the confidential and proprietary property of McElroy Manufacturing, Inc. The drawing is not to be reproduced in any manner, submitted to outside parties for examination, or used directly or indirectly for purposes other than those for which it was furnished without written permission of McElroy Manufacturing, Inc.

2" BULLET ASSEMBLYParts List

ITEM	PART NO.	QTY.	DESCRIPTION
	B2-202	1	ASSEMBLY
1	B2-3001	1	C'BORED SPLITTER BODY(MODULAR)
2	B2-3002	1	TAPPED SPLITTER BODY(MODULAR)
3	B2-3101	1	NOSE CONE (MODULAR)
4	B2-3301	4	SPLITTER BODY SPACER (MODULAR)
5	B2-3602	1	2" EXPANDER/PULLER CONE
6	B2-401	4	GUIDE ROLLER
7	B2-901	1	CUTTER WHEEL-1.312 DIA.
8	B2-902	1	CUTTER WHEEL-1.937 DIA.
9	B2-903	1	CUTTER WHEEL-2.187 DIA.
10	B2-904	1	CUTTER WHEEL-2.875 DIA.
11	MAC00055	12	1/4-20NC X 1"LG SHCS STL PL
12	MCI00023	5	5/16" DIA X 1"LG DOWEL PIN
13	MCI00024	3	3/8" DIA X 1"LG DOWEL PIN
14	MCI00019	2	1/2" DIA X 1-3/4"LG DOWEL PIN

NOTES:

1. Install With Loctite #242.