



McElroy Manufacturing, Inc.  
The leader by design.  
Tulsa, Oklahoma U.S.A.

DRAWN: TLW

CHECK:

APPRV'D:

DATE: 02-06-96

DWG No: B150-200

SHT No: 1

REV No:

PART No: B150-201

CAD FILE No: B150-201

1 1/2" BULLET ASSEMBLY

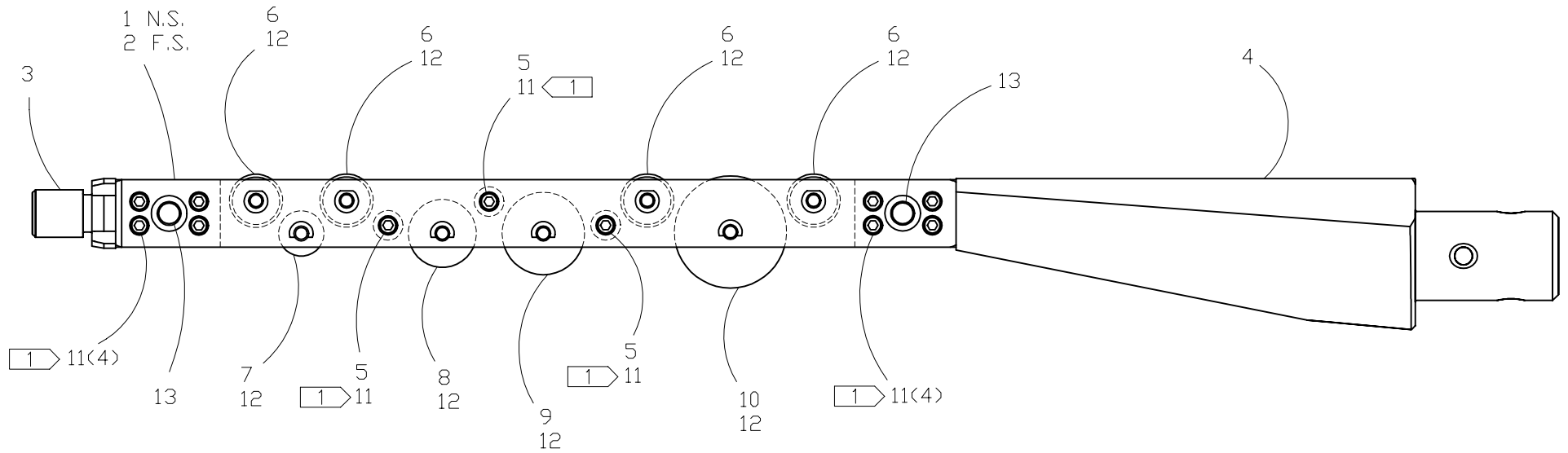

NOTE: This drawing and the information contained therein is the confidential and proprietary property of McElroy Manufacturing, Inc. The drawing is not to be reproduced in any manner, submitted to outside parties for examination, or used directly or indirectly for purposes other than those for which it was furnished without written permission of McElroy Manufacturing, Inc.

**1 1/2" BULLET ASSEMBLY**Parts List

ITEM	PART NO.	QTY.	DESCRIPTION
	<b>B150-201</b>	<b>1</b>	<b>ASSEMBLY</b>
1	B150-1501	1	SPLITTER BODY (COUNTERBORED)
2	B150-1502	1	SPLITTER BODY (TAPPED)
3	B150-1601	1	NOSE CONE
4	B150-1702	1	1-1/2" EXPANDER
5	B150-1801	3	SPLITTER BODY SPACER
6	B150-1901	4	GUIDE ROLLER
7	B150-901	1	CUTTER WHEEL-31/32" DIA.
8	B150-902	1	CUTTER WHEEL-1-7/16" DIA.
9	B150-903	1	CUTTER WHEEL-1-3/4" DIA.
10	B150-904	1	CUTTER WHEEL-2-3/8" DIA.
11	MAC00053	11	1/4-20NC X 3/4"LG SHCS STL BL
12	MCI00021	8	5/16" DIA X 3/4"LG DOWEL PIN
13	MCI00022	2	1/2" DIA X 1-1/4"LG DOWEL PIN

**NOTES:**

1. Install With Loctite #242.