

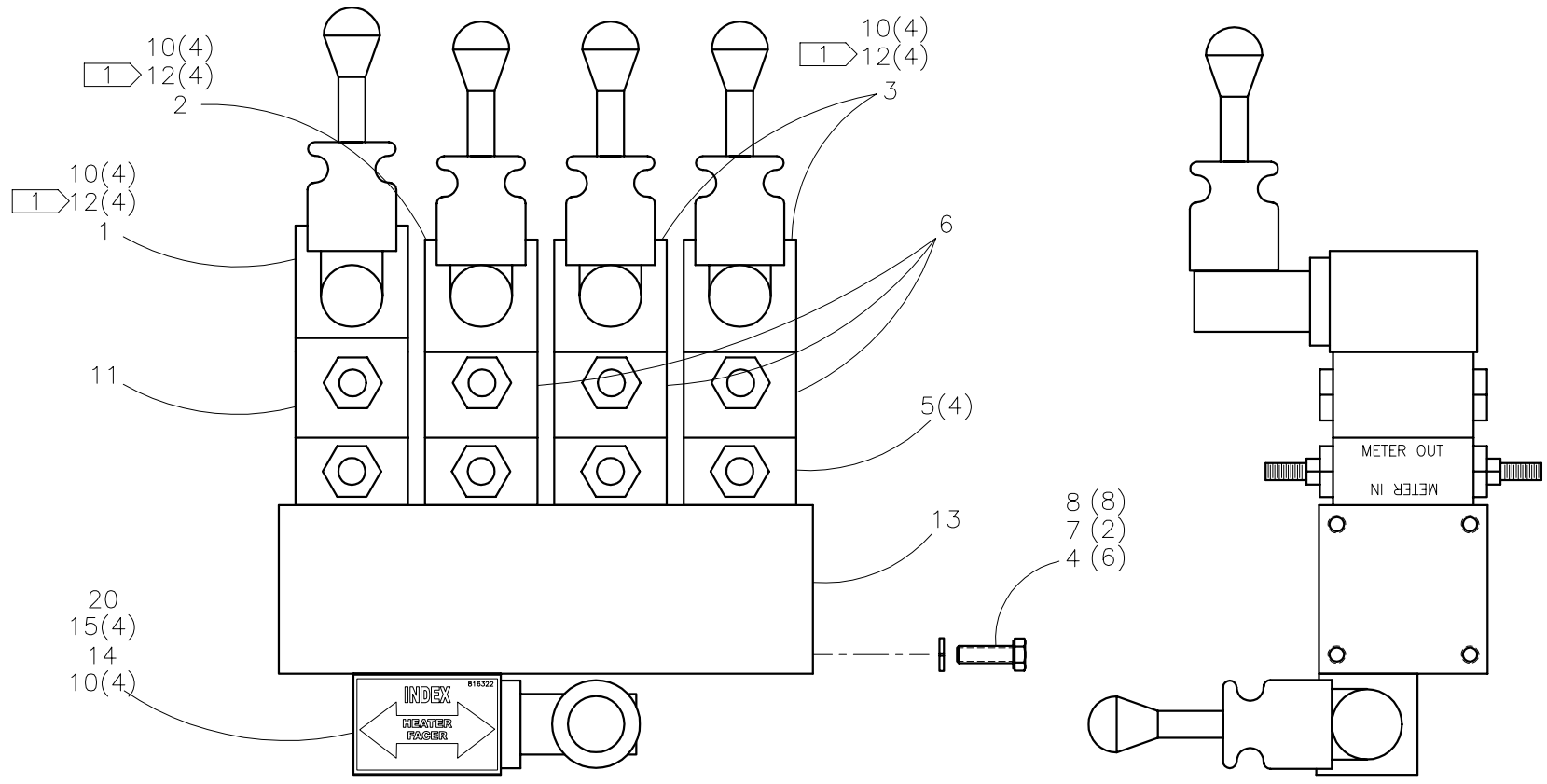

McElroy Manufacturing, Inc.
 The leader by design.
 Tulsa, Oklahoma U.S.A.

DRAWN: TLW	CHECK: SWB	APPRV'D: SWB	DATE: 11/04/99	DWG No.: 2424600	SHT No.: 5	REV No.: B	PART No.: 2424605
#824A/#2065 FIXED JAW STACK ASSEMBLY w/ MODIFIED MANIFOLD							CAD No.: 2424605

NOTE: THIS DRAWING AND THE INFORMATION CONTAINED THEREIN IS THE CONFIDENTIAL AND PROPRIETARY PROPERTY OF McElroy Manufacturing, Inc. THE DRAWING IS NOT TO BE REPRODUCED IN ANY MANNER, SUBMITTED TO OUTSIDE PARTIES FOR EXAMINATION, OR USED DIRECTLY OR INDIRECTLY FOR THE PURPOSES OTHER THAN THOSE FOR WHICH IT WAS FURNISHED WITHOUT WRITTEN PERMISSION OF McElroy Manufacturing, Inc.

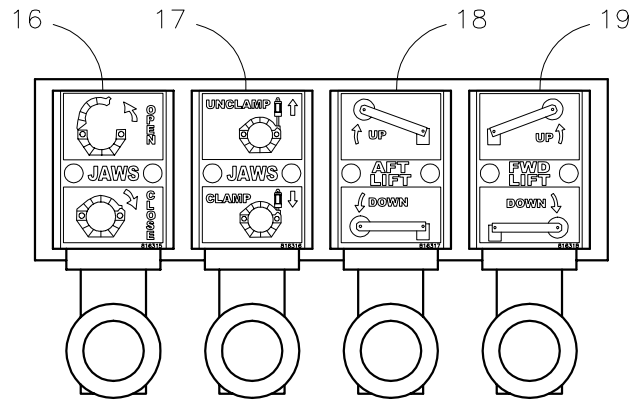

**#824A / #2065 FIXED JAW STACK ASSEMBLY
w/ MODIFIED MANIFOLD**

Parts List

ITEM	PART NO.	QTY.	DESCRIPTION
	2424605		ASSEMBLY
1	MEF00016	1	DIRECTIONAL VALVE
2	MEF00017	1	DIRECTIONAL VALVE
3	MEF00015	2	DIRECTIONAL VALVE
4	MAB00032	6	5/16-18NC X 3/4" LG HHCS
5	MEJ00001	4	FLOW CONTROL VALVE
6	MEJ00002	3	CHECK VALVE
7	MAB00033	2	5/16-18NC X 1" LG HHCS
8	MBE00006	8	5/16" LOCK WASHER
9			
10	MBE00004	20	#10 REG SPLIT LK WASHER
11	MEH00005	1	RELIEF VALVE
12	MAC00049	16	#10-24NC X 4-1/4" LG SHCS
13	3601001	1	MODIFIED MANIFOLD
14	MEF00048	1	DIRECTIONAL VALVE
15	MAC00040	4	#10-24NC X 1" LG SHCS
16	816315	1	JAWS OPEN/CLOSE LABEL
17	816316	1	JAWS CLAMP/UNCLAMP LABEL
18	816317	1	AFT PIPE LIFT UP/DOWN LABEL
19	816318	1	FWD PIPE LIFT UP/DOWN LABEL
20	816322	1	INDEX HEATER/FACER LABEL

NOTES:

- TORQUE TO 4-5 FT LBS (48-60 IN. LBS)
- USE #MDL00093 FOR REPLACEMENT O-RING NUMBERS FOR ITEMS: 1,2,3,5,6, & 11.
QUANTITY OF (4) FOR EACH ITEM.
- THIS ASSEMBLY IS USED ON ALL #824 MACHINES INCLUDING AND AFTER S/N 345120.

DRAWING REVISION HISTORY LISTING

PART NO: 2424605

DESCRIPTION: #824A/#2065 FIXED JAW STACK ASSEMBLY w/ MODIFIED MANIFOLD

<u>APPR.</u>	<u>REV</u>	<u>DATE</u>	<u>BY</u>	<u>DESCRIPTION OF REVISION</u>
SWB	A	06/07/05	JAB	CORRECTED DRAWING & MOUNTING HARDWARE OF ITEM #11 RELIEF VALVE TO MATCH AS BUILT. ADDED QTY TO ALL ITEMS FOR CLARITY.
SPA	B	12/19/05	JAB	REMOVED ITEM 9 (MAC00048) AND CHANGED QTY OF ITEM 12 (MAC00049) FROM 4 TO 16. CHANGES MADE TO ALLOW MORE THREAD ENGAGEMENT INTO MANIFOLD AND EASE ASSEMBLY PROCESS. ALSO ADDED NOTE 1 TO ENSURE PROPER TORQUE ON MOUNTING BOLTS.