



McElroy Manufacturing, Inc.

The leader by design.

Tulsa, Oklahoma U.S.A.

DRAWN: RLE

CHECK: TLW

APPRVD: SWB

DATE: 3/15/99

SHT No: 1

REV No: G

PART No: 4829101

1648 ROLLING CHASSIS ASSEMBLY

NOTE: THIS DRAWING AND THE INFORMATION CONTAINED THEREIN IS THE CONFIDENTIAL AND PROPRIETARY PROPERTY OF McElroy Manufacturing, Inc. THE DRAWING IS NOT TO BE REPRODUCED IN ANY MANNER, SUBMITTED TO OUTSIDE PARTIES FOR EXAMINATION, OR USED DIRECTLY OR INDIRECTLY FOR THE PURPOSES OTHER THAN THOSE FOR WHICH IT WAS FURNISHED WITHOUT WRITTEN PERMISSION OF McElroy Manufacturing, Inc.

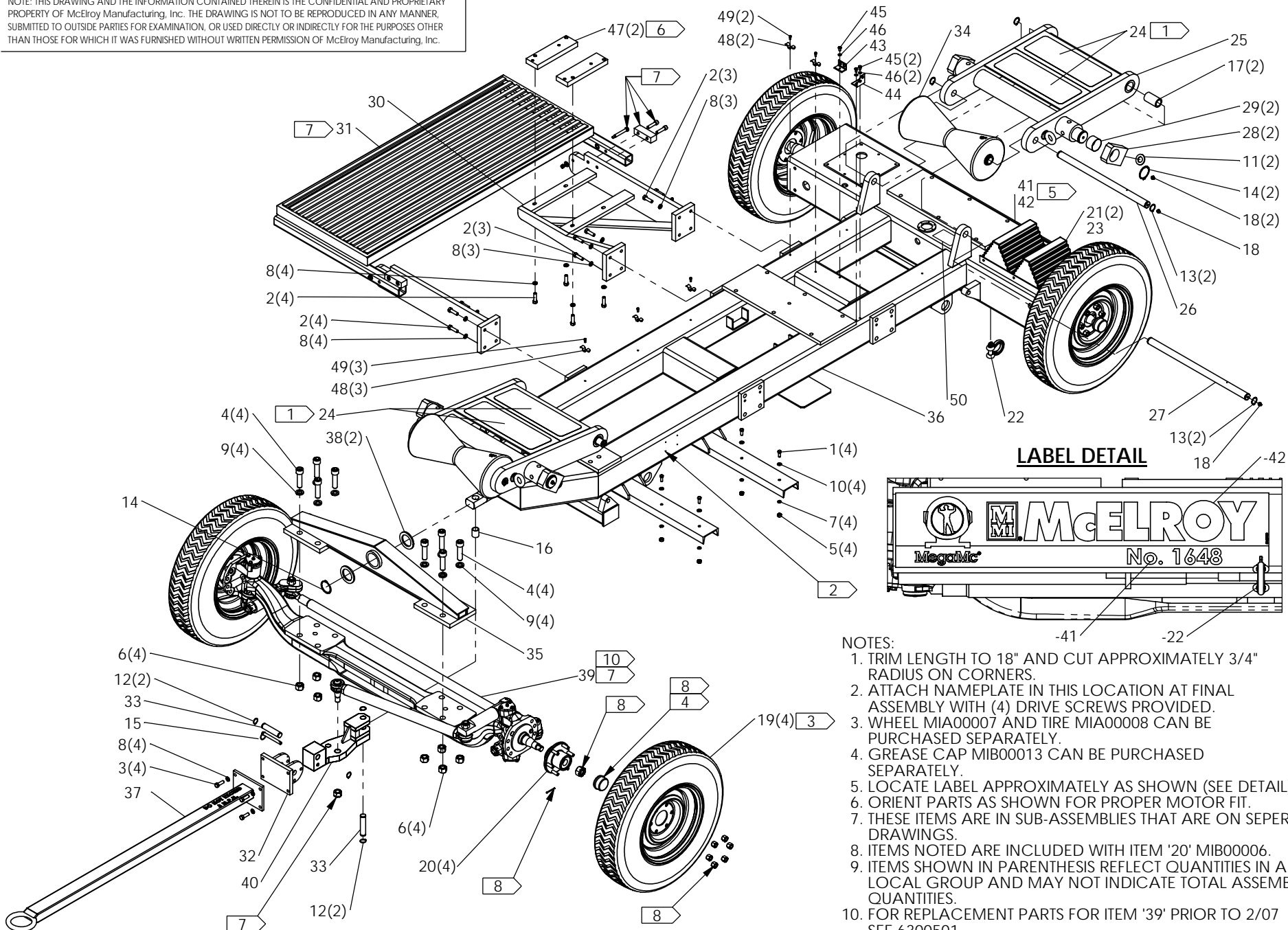

LABEL DETAIL

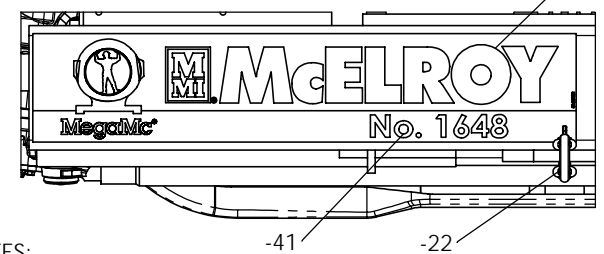

- NOTES:
1. TRIM LENGTH TO 18" AND CUT APPROXIMATELY 3/4" RADIUS ON CORNERS.
 2. ATTACH NAMEPLATE IN THIS LOCATION AT FINAL ASSEMBLY WITH (4) DRIVE SCREWS PROVIDED.
 3. WHEEL MIA00007 AND TIRE MIA00008 CAN BE PURCHASED SEPARATELY.
 4. GREASE CAP MIB00013 CAN BE PURCHASED SEPARATELY.
 5. LOCATE LABEL APPROXIMATELY AS SHOWN (SEE DETAIL).
 6. ORIENT PARTS AS SHOWN FOR PROPER MOTOR FIT.
 7. THESE ITEMS ARE IN SUB-ASSEMBLIES THAT ARE ON SEPARATE DRAWINGS.
 8. ITEMS NOTED ARE INCLUDED WITH ITEM '20' MIB00006.
 9. ITEMS SHOWN IN PARENTHESIS REFLECT QUANTITIES IN A LOCAL GROUP AND MAY NOT INDICATE TOTAL ASSEMBLY QUANTITIES.
 10. FOR REPLACEMENT PARTS FOR ITEM '39' PRIOR TO 2/07 SEE 6300501.

#1648 ROLLING CHASSIS ASSEMBLY

Parts List

ITEM	PART NO.	QTY.	DESCRIPTION
	4829101		ASSEMBLY
1	MAB00064	4	3/8-16NC x 1" LG. HHCS
2	MAB00104	14	1/2-13NC x 1-3/4 LG. HHCS
3	MAB00082	4	1/2-13NC x 1-1/2 LG. HHCS
4	MAN00060	8	7/8-9NC x 3-1/4 LG. SHCS SS
5	MBA00007	4	3/8-16NC HEX NUT
6	MBA00013	8	7/8-9NC HEX NUT
7	MBE00007	4	3/8" LOCK WASHER
8	MBE00009	18	1/2" LOCK WASHER
9	MBE00013	8	7/8" LOCK WASHER
10	MBF00007	4	3/8" FLAT WASHER
11	MBG00011	4	1" FLAT WASHER
12	MCB00006	4	EXTERNAL SNAP RING
13	MCB00008	8	EXTERNAL SNAP RING
14	MCB00018	5	EXTERNAL SNAP RING
15	MCE00014	1	1/2 DIA. x 4.10 GRIP DETENT PIN
16	MDM00106	1	BUSHING
17	MDM00107	4	BUSHING
18	MFJ00002	8	1/8 NPT GREASE ZERK
19	MIA00013	4	WHEEL & TIRE ASSEMBLY
20	MIB00006	4	HUB W/ BEARING, SEAL, CAPS & LUG NUTS
21	MIE00007	2	WHEEL CHOCK
22	MJD00012	1	5/8", 5-TON SHACKLE
23	MJG00001	1	9" RUBBER BUNGE CORD W/S-HOOK
24	MJQ00188	6 FT	SAFE-T-WALK W/PRESSURE SENSITIVE ADHESIVE
25	4805103	2	PIPE LIFT ROLLER SUPPORT WELDMENT
26	4805501	2	PIPE LIFT SHAFT
27	4805502	2	PIPE LIFT SHAFT
28	4805701	4	PIPE LIFT FEMALE EYE
29	4805801	4	PIPE LIFT FEMALE EYE BUSHING
30	4806301	1	PUMP MOUNT WELDMENT
31	4806401	1	OPERATOR PLATFORM ASSEMBLY
32	4808101	1	FORWARD-REVERSE CYLINDER MOUNTING BRACKET
33	4808401	2	HITCH PIN
34	4814702	2	PIPE LIFT ROLLER ASSEMBLY
35	4815307	1	FRONT AXLE SUPPORT ASSEMBLY
36	4818701	1	CHASSIS
37	4823801	1	TOW BAR WELDMENT
38	4824602	2	FRONT AXLE SUPPORT THRUST WASHER
39	4831301	1	48 FRONT AXLE MOD ASSEMBLY
40	6307102	1	STEERING ARM ADAPTER WELDMENT

#1648 ROLLING CHASSIS ASSEMBLY

Parts List

ITEM	PART NO.	QTY.	DESCRIPTION
41	8163128	1	NO. 1648 LABEL
42	8163122	1	MEGAMC McELROY LABEL
43	3613501	1	1/2" NPTF BULKHEAD FITTING ANGLE CLIP
44	4826901	1	JAW CLAMP CYLINDER HOSE CLIP
45	MAB00031	3	5/16-18NC x 1/2 LG. HHCS
46	MBE00006	3	5/16" LOCK WASHER
47	4830001	2	MOTOR MOUNT ADAPTER PLATE
48	MHA00032	5	5/8" HOSE CLAMP
49	MAH00050	5	1/4-20NC x 1/2 LG. SHCS SS
50	8163106	1	HYDRAULIC OIL SPECIFICATION LABEL

DRAWING REVISION HISTORY LISTING

PART NO: 4829101
DESCRIPTION: #1648 ROLLING CHASSIS ASSEMBLY

<u>APPR.</u>	<u>REV</u>	<u>DATE</u>	<u>BY</u>	<u>DESCRIPTION OF REVISION</u>
TLW	--	07/07/99	RLE	UPDATED PICTURE & REVISED QTY. OF ITEM #24 MJQ00188 FROM 4.5 FT. TO 6 FT.
TLW	A	01/04/01	BWW	REVISED TO ADD ITEM #47 4830001 QTY 2 AND INCREASE QTY OF ITEM #2 FROM 10 TO 14 AND #8 FROM 14 TO 18. REVISED TO PROPER MOTOR MOUNTING BRACKET ORIENTATION FOR CLARITY PER ASSEMBLY REQUEST.
SWB	B	07/25/02	BWW	REVISED TO REMOVE ITEM #41 841201 NAMEPLATE. ITEM TO BE ADDED AT FINAL ASSEMBLY. CHANGED ITEM 43 FROM 4826801 TO 3613501 QTY 1. ADDED ITEM 48 MHA00032 QTY 5 AND ITEM 49 MAH00050 QTY 5. CHANGES MADE TO MATCH AS BUILT CONDITION.
SWB	C	03/11/03	BWW	REVISED TO ADD NOTE 2 FOR ATTACHMENT OF NAME PLATE AT FINAL ASSEMBLY.
SWB	D	04/25/03	BWW	ADDED PARTS CONTAINED WITHIN ITEM 20 MIB00006 TO DESCRIPTION FOR CLARITY. ADDED NOTE 3 FOR PURCHASING OF WHEEL AND TIRE FOR ITEM 19 SEPARATELY. REMOVED PART NUMBERS FOR TIRE AND WHEEL FROM DESCRIPTION OF ITEM 19. ADDED NOTE 4 FOR PURCHASING GREASE CAP MIB00013 SEPARATELY.
SWB	E	10/26/04	MLM	REVISED TO ADD ITEM-50 (HYDRAULIC OIL SPECIFICATION LABEL-8163106)
SWB	F	2/9/05	RLE	REVISED ITEM #42 4824301 TO 8163122 & ADDED ITEM #41 8163128 QTY. (1). ADDED DETAIL AND NOTE 5 TO CLARIFY LABEL LOCATION FOR NEW BRANDING LABEL.
SPA	G	3/20/07	ARB	REDRAWN FOR PARTS FINDER, AND REVISED ITEM '39' FROM (6300501) TO (4831301) TO IMPROVE MANUEVERABILITY, REVISED ITEM '4' FROM (MAC00200) TO (MAN00060) TO REMOVE BLACK BOLTS. ALSO ADDED NOTES '6, 7, 8, 9, 10' FOR CLARITY.