

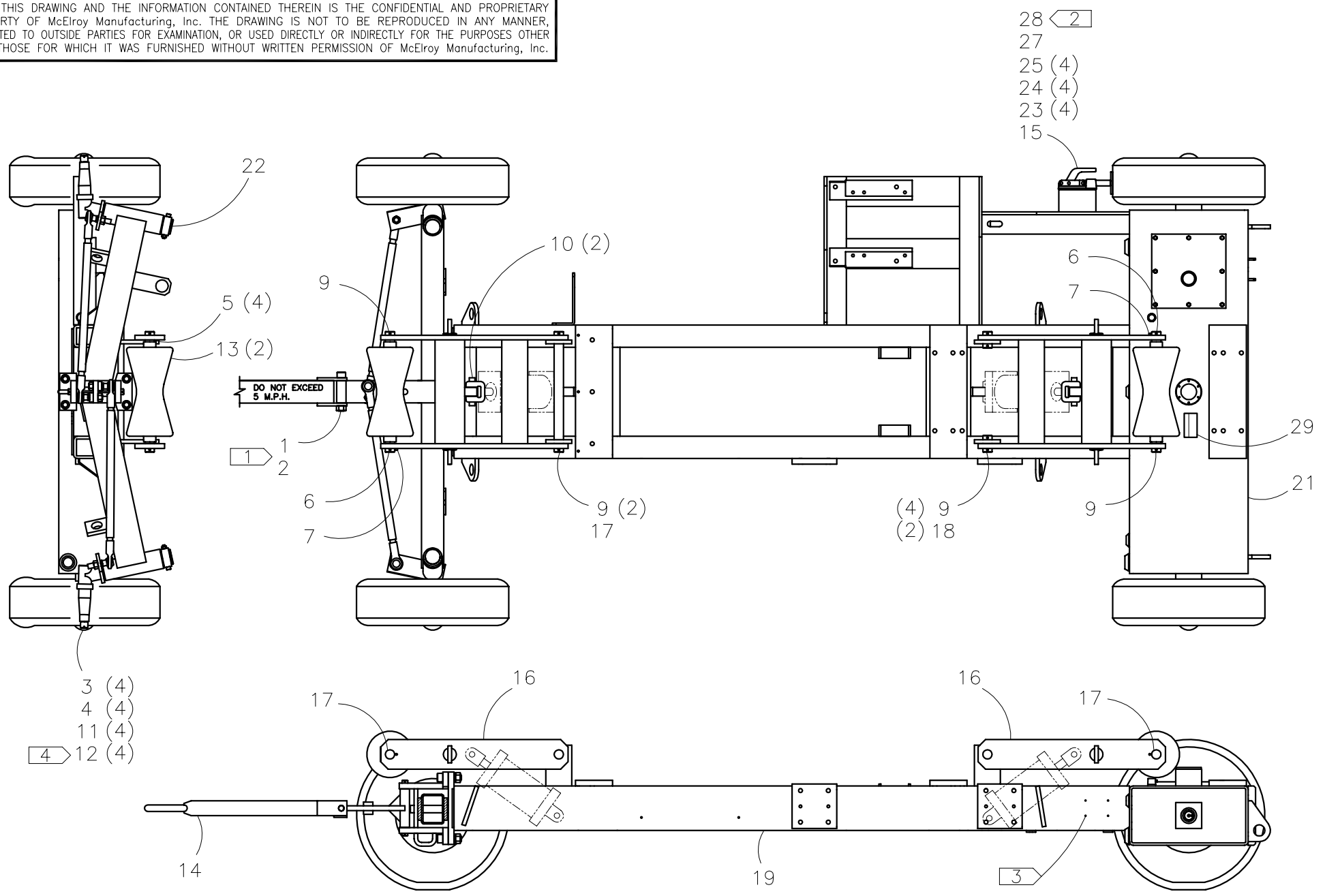

McElroy Manufacturing, Inc.
 The leader by design.
 Tulsa, Oklahoma U.S.A.

DRAWN: TGW	CHECK: TLW	APPRV'D: SWB	DATE: 9/23/98	DWG No.: 3631300	SHT No.: 1	REV No.: G	PART No.: 3631301
#824A/#1236A ROLLING CHASSIS ASSEMBLY							CAD No.: 3631301

NOTE: THIS DRAWING AND THE INFORMATION CONTAINED THEREIN IS THE CONFIDENTIAL AND PROPRIETARY PROPERTY OF McElroy Manufacturing, Inc. THE DRAWING IS NOT TO BE REPRODUCED IN ANY MANNER, SUBMITTED TO OUTSIDE PARTIES FOR EXAMINATION, OR USED DIRECTLY OR INDIRECTLY FOR THE PURPOSES OTHER THAN THOSE FOR WHICH IT WAS FURNISHED WITHOUT WRITTEN PERMISSION OF McElroy Manufacturing, Inc.



#824A/#1236A ROLLING CHASSIS ASSEMBLYPARTS LIST

ITEM	PART NO.	QTY	DESCRIPTION
	3631301		ASSEMBLY
1	MAC00192	1	3/4-10 NC x 4-1/2" LG. SHCS
2	MBA00012	1	3/4-10 NC HEX NUT
3	MBD00041	4	1-14UNS AXLE NUT
4	MBE00017	4	LOCK WASHER
5	MBF00015	4	1-1/4" FLAT WASHER
6	MCG00031	2	1/4" DIA. x 2" LG. ROLL PIN
7	MCG00032	2	1/4" DIA. x 3/4" LG. ROLL PIN
8			
9	MCH00003	6	3/16" DIA. x 1-1/2" LG. COTTER PIN
10	MEK00006	2	FEMALE ROD CLEVIS W/ PIN & COTTERS
11	MIA00004	4	WHEEL & TIRE ASSEMBLY
12	MIB00002	4	HUB W/ BEARING, SEAL, CAPS & LUG NUTS
13	3603304	2	PIPE LIFT ROLLER
14	3612101	1	TOW BAR ASSEMBLY
15	MJA00006	1	TOGGLE CLAMP
16	3612802	2	PIPE LIFT WELDMENT
17	3612803	3	PIPE LIFT PIVOT PIN/ROLLER PIN
18	3612805	2	PIPE LIFT PIVOT PIN (AFT)
19	3616001	1	CHASSIS ASSEMBLY
20			
21	8163122	1	MEGAMC McELROY LABEL
22	3631201	1	FRONT AXLE ASSEMBLY
23	MAA00033	4	5/16-18 NC x 1" LG. HHCS
24	MBA00006	4	5/16-18 NC HEX NUT
25	MBE00006	4	5/16" LOCK WASHER
26			
27	1857001	1	BRAKE PAD
28	MAD00073	1	3/8-16NCX1LG FHSCS
29	8163106	1	HYDRAULIC OIL SPECIFICATION LABEL

NOTES:

1. INSTALL WITH MEDIUM STRENGTH THREAD LOCKING COMPOUND.
2. INSTALL WITH HIGH STRENGTH THREAD LOCKING COMPOUND.
3. ATTACH NAMEPLATE AT FINAL ASSEMBLY WITH (4) DRIVE SCREWS.
4. GREASE CAP MIB00013 CAN BE PURCHASED SEPARATELY.

DRAWING REVISION HISTORY LISTING

PART NO: 3631301
DESCRIPTION: #824/#1236 ROLLING CHASSIS ASSEMBLY

<u>APPR.</u>	<u>REV</u>	<u>DATE</u>	<u>BY</u>	<u>DESCRIPTION OF REVISION</u>
SWB	A	1/11/99	DJL	ITEM 15 WAS PARKING BRAKE WELDMENT(3612603) ADDED ITEMS 27,28 & NOTE 2. CHANGED PARKING BRAKE TO BE CONSISTENT WITH 412/618 PARKING BRAKE.
TLW	B	2/24/99	AH	DELETED ITEMS #8(MCH00001) & #20(3617101) AND REVISED ITEM #10(MEK00006) FEMALE ROD CLEVIS TO FEMALE ROD CLEVIS WITH PIN AND COTTERS.
SWB	--	4/10/01	RLE	REVISED ITEM #3 FROM MBC00018 TO MBD00041 TO ELIMINATE DUPLICATE PART NUMBER.
LAA	C	7/8/02	ALK	REMOVED ITEM #26 841201 NAMEPLATE. ITEM TO BE ADDED AT FINAL ASSEMBLY. UPDATED ITEM 19 3616001 CHASSIS ASSEMBLY TO SHOW HEATER SUPPORT RAILS.
SWB	D	03/17/03	BWW	REVISED TO ADD NOTE 3 FOR ATTACHMENT OF NAMEPLATE AT FINAL ASSEMBLY.
SWB	E	04/25/03	BWW	ADDED PARTS CONTAINED WITHIN ITEM 12 MIB00002 TO DESCRIPTION FOR CLARITY. ADDED NOTE 4 FOR ORDERING GREASE CAP SEPARATELY.
SWB	F	10/25/04	MLM	REVISED TO ADD ITEM-29 (HYDRAULIC OIL SPECIFICATION LABEL- 8163106)
SWB	G	05/13/05	JAB	REVISED ITEM #21 FROM 4824301 TO 8163122. CHANGED ITEM #14 TO REFLECT AS BUILT.