

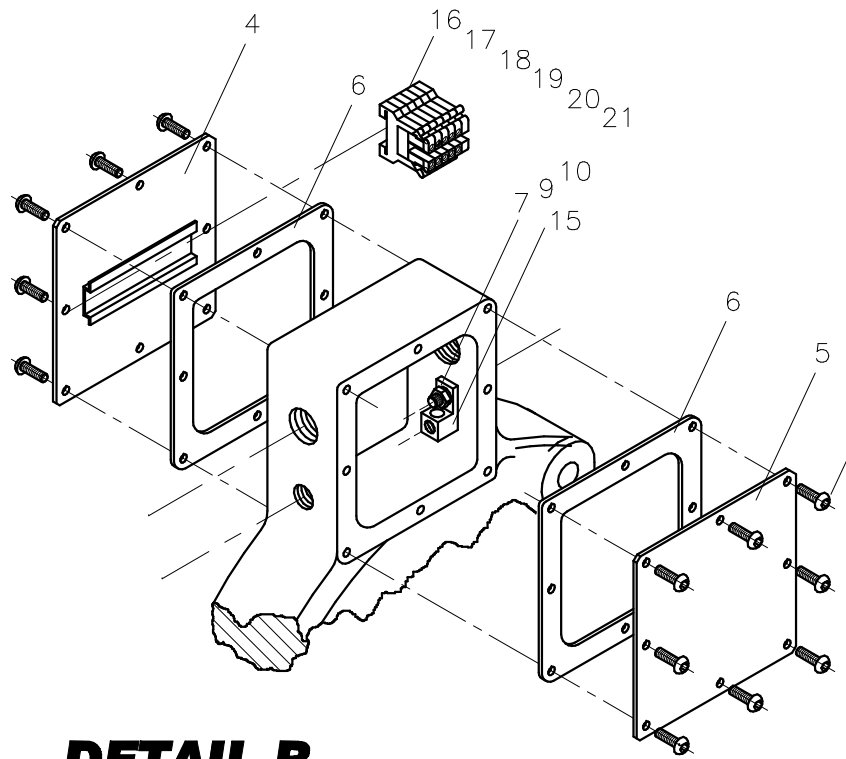

**McElroy Manufacturing, Inc.**  
 The leader by design.  
 Tulsa, Oklahoma U.S.A.

DRAWN: AH	CHECK: BWP	APPRV'D: B	DATE: 1/31/96	DWG No: 3608000	SHT No: 2	REV No: D	PART No: 3608002
#824A HEATER PIVOT ARM JUNCTION BOX ASSEMBLY							CAD No: 3608002

NOTE: THIS DRAWING AND THE INFORMATION CONTAINED THEREIN IS THE CONFIDENTIAL AND PROPRIETARY PROPERTY OF McElroy Manufacturing, Inc. THE DRAWING IS NOT TO BE REPRODUCED IN ANY MANNER, SUBMITTED OUTSIDE PARTIES FOR EXAMINATION, OR USED DIRECTLY OR INDIRECTLY FOR THE PURPOSES OTHER THAN THOSE FOR WHICH IT WAS FURNISHED WITHOUT WRITTEN PERMISSION OF McElroy Manufacturing, Inc.



**DETAIL B**

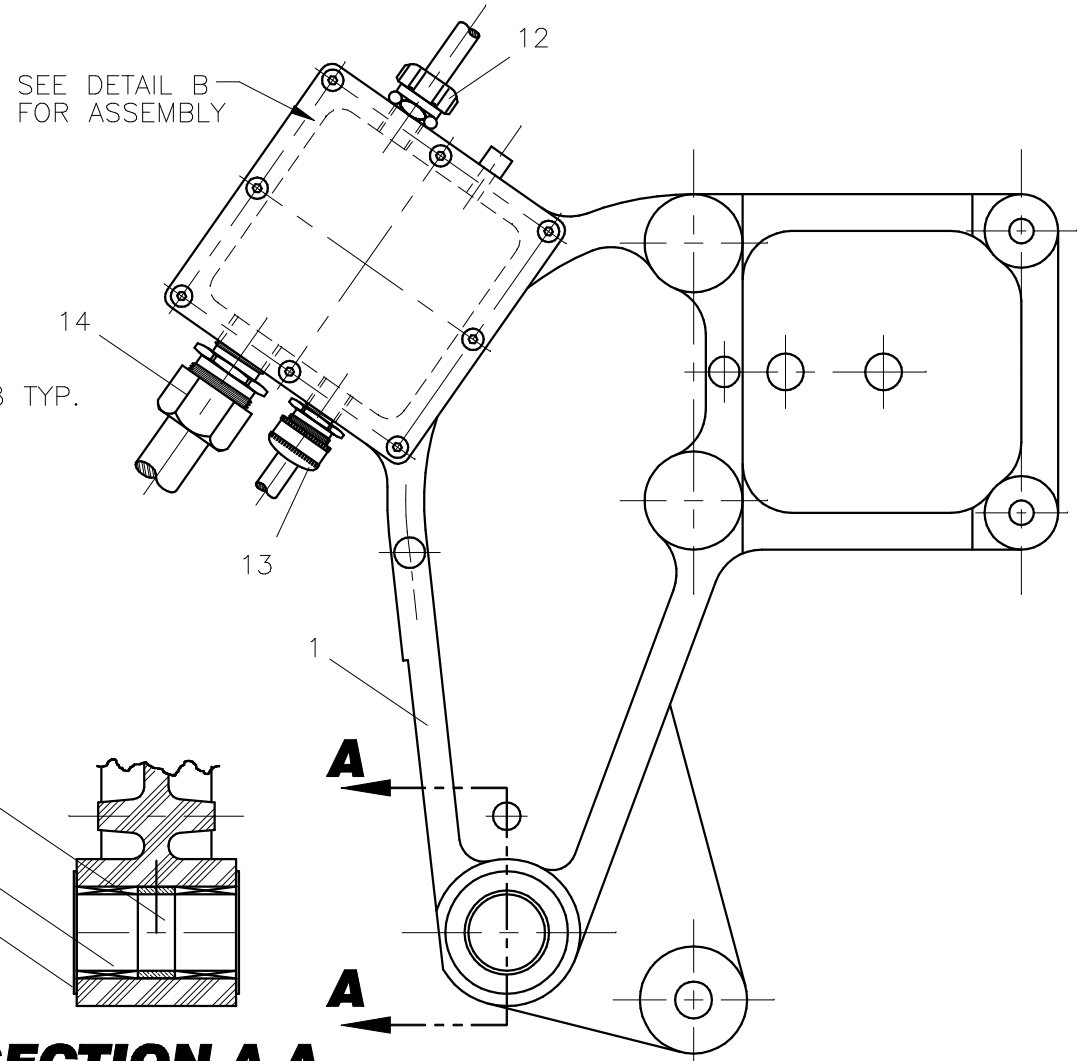

SEE DETAIL B FOR ASSEMBLY

**SECTION A-A**

**#824A HEATER PIVOT ARM JUNCTION BOX ASSEMBLY**Parts List

ITEM	PART NO.	QTY.	DESCRIPTION
	<b>3608002</b>		<b>ASSEMBLY</b>
1	2419707	1	PIVOT ARM, 24" HEATER
2	3602206	2	OUTER SPACER-PIVOT ARM
3	3602207	1	INNER SPACER-PIVOT ARM
4	3608005	1	COVER W/RAIL-HEATER PIVOT ARM
5	3608006	1	COVER-PIVOT ARM/JUNCTION BOX
6	3608007	2	GASKET-PIVOT ARM/JUNCTION BOX
7	MAC00056	1	1/4-20NC X 1-1/4"LG SHCS STL PL
8	MAH00111	16	10-24NC X 1/2"LG HHWF ROLL FORMING ST. SCR
9	MBA00005	1	1/4-20NC FINISHED HEX NUT STL PL
10	MBE00005	1	1/4" REG SPLIT LK WASHER STL PL
11	MDM00074	2	NEEDLE BEARING
12	MLJ00012	1	CONDUIT CONNECTOR 1/2" STR.
13	MLK00015	1	1/2" STRAIN RELIEF CONNECTOR
14	MLK00016	1	1" STRAIN RELIEF CONNECTOR
15	MLM00037	1	SOLDERLESS GROUND LUG
16	MLM00051	2	TERMINAL
17	MLM00055	1	END COVER
18	MLM00056	2	END CLAMP
19	MLM00057	2	TRANSPARENT MARKER CARRIER
20	MLM00060	3	TRANSPARENT MARKER CARRIER
21	MLM00068	3	TERMINAL

## DRAWING REVISION HISTORY LISTING

**PART NO:** 3608002

**DESCRIPTION:** #824A HEATER PIVOT ARM JUNCTION BOX ASSEMBLY

<u>APPR.</u>	<u>REV</u>	<u>DATE</u>	<u>BY</u>	<u>DESCRIPTION OF REVISION</u>
TLW	---	7/8/98	TGW	REVISED ITEM #8 P/N FROM MAE00024 TO MAH00111.