



McElroy Manufacturing, Inc.

The leader by design.

Tulsa, Oklahoma U.S.A.

DRAWN: SS

CHECK: BWP

APPRVD: B

DATE: 10/07/96

SHT No: 3

REV No: E

PART No: 2421301

824A OUTER MOVABLE JAW ASSEMBLY

NOTE: THIS DRAWING AND THE INFORMATION CONTAINED THEREIN IS THE CONFIDENTIAL AND PROPRIETARY PROPERTY OF McElroy Manufacturing, Inc. THE DRAWING IS NOT TO BE REPRODUCED IN ANY MANNER, SUBMITTED TO OUTSIDE PARTIES FOR EXAMINATION, OR USED DIRECTLY OR INDIRECTLY FOR THE PURPOSES OTHER THAN THOSE FOR WHICH IT WAS FURNISHED WITHOUT WRITTEN PERMISSION OF McElroy Manufacturing, Inc.

NOTES:

1. HAND GRIND OFF RIDGES ON TOP OF BOLTS.
2. LOCATE PORT ON NEAR SIDE.
3. INSTALL WITH HIGH STRENGTH THREAD LOCKING COMPOUND.
4. ORDER # A2409702 LOWER OUTER MOVABLE JAW KIT. INCLUDES ITEMS 2, 12, 14 THRU 18 & 22 PRE-ASSEMBLED.

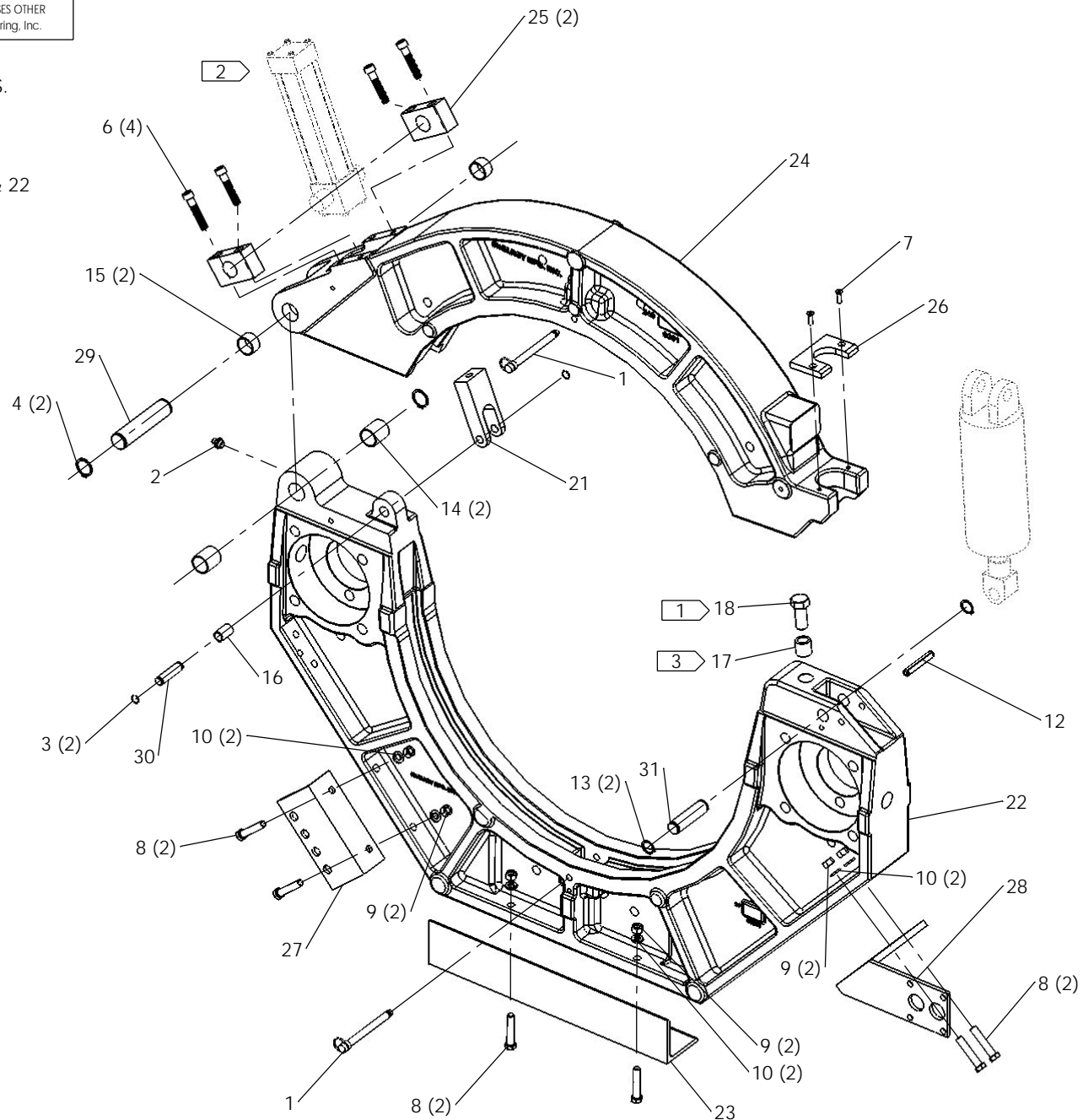

#824A OUTER MOVABLE JAW ASSEMBLYPARTS LIST

ITEM	PART NO.	QTY	DESCRIPTION
	2421301		ASSEMBLY
1	MCE00004	2	3/8" DIA. x 3.75" GRIP DETENT PIN
2	MFJ00002	1	1/8 NPT GREASE ZERK
3	MCB00001	2	EXTERNAL SNAP RING
4	MCB00006	2	EXTERNAL SNAP RING
5			
6	MAC00338	4	3/8-24NF x 2" LG. SHCS
7	MAD00033	2	#10-24NC x 3/4" LG. FHSCS
8	MAB00068	6	3/8-16NC x 2" LG. HHCS
9	MBA00007	6	3/8-16NC FINISHED HEX NUT
10	MBE00007	6	3/8" REGULAR SPLIT LOCK WASHER
11			
12	MCG00023	1	3/8" DIA. x 2-1/2" LG. ROLL PIN
13	MCB00003	2	EXTERNAL SNAP RING
14	MDM00004	2	BUSHING
15	MDM00003	2	BUSHING
16	MDM00001	1	BUSHING
17	MJM00002	1	5/8-18 x 7/8-14 THREAD INSERT
18	MAH00038	1	5/8-18NF x 1-1/2" LG. HHCS W/NYLON LOCK
19			
20			
21	2402202	1	UPPER JAW PIVOT CYLINDER CLEVIS
22	2409702	1	LOWER OUTER MOVABLE JAW
23	3601501	1	CARRIAGE HOSE TROUGH
24	2409901	1	UPPER JAW
25	3607101	2	TRUNNION BLOCK ASSEMBLY
26	2416701	1	UPPER JAW CLAMP PAD
27	2423701	1	PLUMBING MOUNTING ANGLE
28	2424006	1	MOVABLE JAW VALVE STACK MOUNTING BRACKET
29	2414001	1	1" DIA. JAW PIN
30	2414002	1	1/2" DIA. JAW PIN
31	2414003	1	3/4" DIA. JAW PIN

DRAWING REVISION HISTORY LISTING

PART NO: 2421301
DESCRIPTION: #824A OUTER MOVABLE JAW ASSEMBLY

<u>APPR.</u>	<u>REV</u>	<u>DATE</u>	<u>BY</u>	<u>DESCRIPTION OF REVISION</u>
SWB	B	10/26/98	TGW	ADDED ITEMS 8, 9, 10, 23, 27 & 28.
TLW	-	5/20/99	DJL	ADDED NOTE 4 FOR PRE-ASSEMBLED JAW KIT.
MLM	C	5/13/03	RLE	REVISED ITEM #7, MAD00032 #10-24NC x 5/8 LG. FHSCS, TO MAD00033 #10-24NC x 3/4 LG. FHSCS. NEEDED LONGER SCREW DUE TO INCREASE IN UPPER JAW CLAMP PAD THICKNESS.
SWB	D	01/04/05	BWW	REMOVED ITEM 32 2415901 TO MATCH AS BUILT CONDITION. THIS REVISION TOOK EFFECT WITH THE REVISION OF 2400801 HYDRAULIC SCHEMATIC ON 4/15/03.
SWB	E	1/08/07	PJD	REVISED AND REDRAWN TO SHOW EXPLODED VIEW TO IMPROVE CLARITY FOR ASSEMBLY