



McElroy Manufacturing, Inc.
The leader by design.
Tulsa, Oklahoma U.S.A.

DRAWN: BWW	CHECK: TMT/BP	APPRV'D: SWB	DATE: 6/07/00	SHT No: 1	REV No: E	PART No: 433701
------------	---------------	--------------	---------------	-----------	-----------	-----------------

PitBull® No. 14 FACER ASSEMBLY 100-120V, 50/60Hz, 1Ph

NOTE: THIS DRAWING AND THE INFORMATION CONTAINED THEREIN IS THE CONFIDENTIAL AND PROPRIETARY PROPERTY OF McElroy Manufacturing, Inc. THE DRAWING IS NOT TO BE REPRODUCED IN ANY MANNER, SUBMITTED OUTSIDE PARTIES FOR EXAMINATION, OR USED DIRECTLY OR INDIRECTLY FOR THE PURPOSES OTHER THAN THOSE FOR WHICH IT WAS FURNISHED WITHOUT WRITTEN PERMISSION OF McElroy Manufacturing, Inc.

NOTES:

1. ON OUTER RACE ONLY, CLEAN WITH SOLVENT, ASSEMBLE WITH LOCTITE #680.
2. USE PERMATEX #2C NON-HARDENING SEALANT AT JOINT COMMON TO FACER BODY & COVER.
3. HANDLE ONLY MAY BE ORDERED AS MJQ00060.
4. INSTALL SCREWS USING 40-45 PSI AIR PRESSURE AND A THREAD LUBE.
5. ADD HIGH TEMPERATURE GREASE TO INSIDE CAVITY.
6. INSTALL WITH C5-A HIGH TEMP ANTI-SEIZE LUBRICANT. CLEAN OFF EXCESS.
7. FOR REPLACEMENT BLADES ORDER 413702 WHICH CONTAINS (4) 413701, FACER BLADES

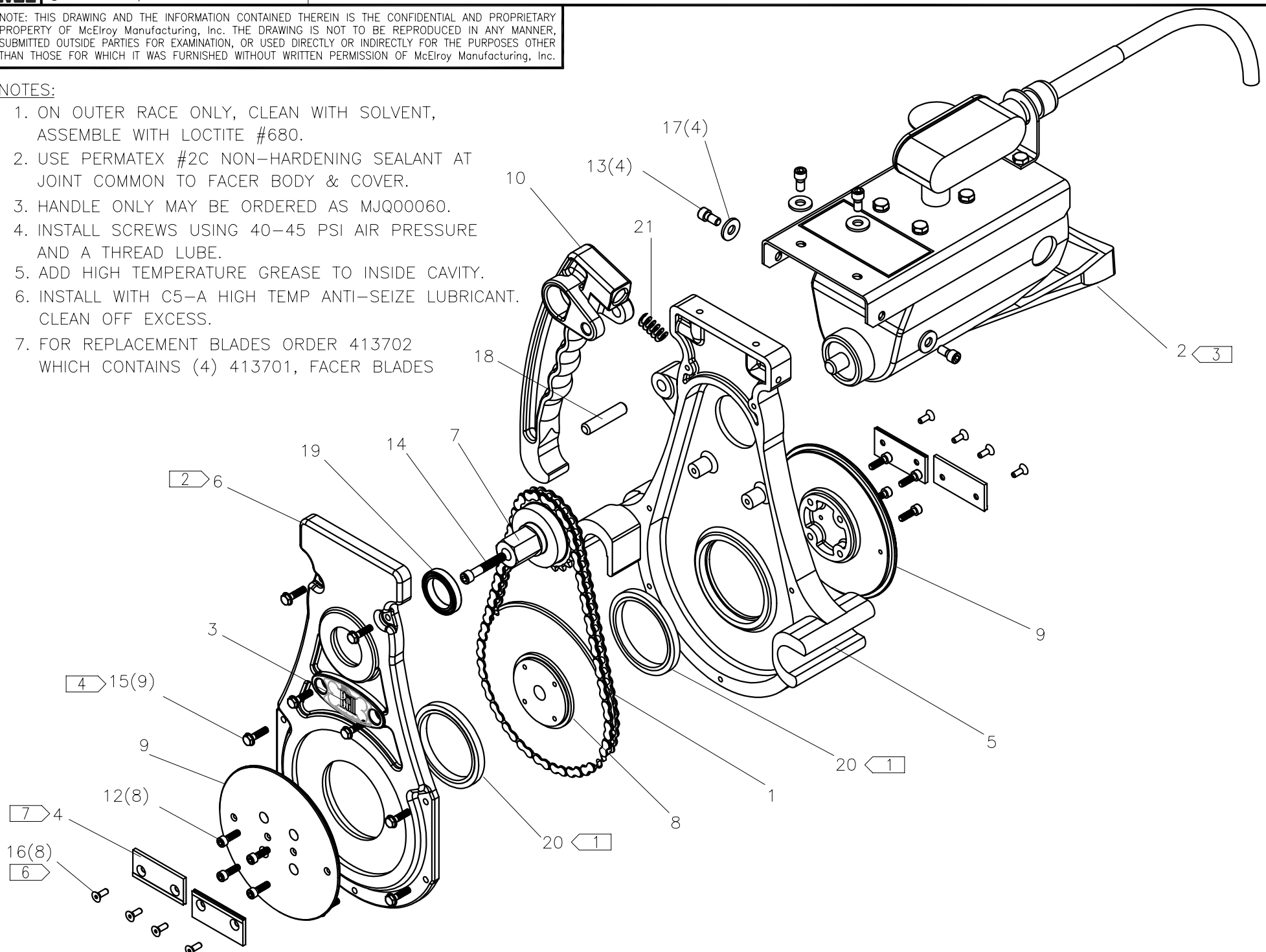

PitBull® No. 14 FACER ASSEMBLY
100-120V, 50/60Hz, 1Ph

PARTS LIST

ITEM	PART NO.	QTY.	DESCRIPTION
	433701		Assembly
1	A422701	1	FACER CHAIN ASSEMBLY
2	A424101	1	FACER MOTOR ASS'Y
3	433801	1	PitBull® No. 14 OVAL STICKER
4	413701	4	FACER BLADE 2.25 LG
5	432101	1	PitBull® No. 14 FACER BODY
6	432001	1	PitBull® No. 14 FACER COVER
7	417202	1	DRIVER SPROCKET WELDMENT
8	417301	1	DRIVEN SPROCKET
9	432501	2	PitBull® No. 14 BLADE HOLDER
10	433002	1	PitBull® No. 14 LATCH HANDLE
11			
12	MAC00037	8	10-24NC X 5/8"LG SHCS
13	MAC00051	4	1/4-20NC X 1/2"LG SHCS
14	MAC00065	1	1/4-20NC X 1-1/2"LG L/H SHCS
15	MAH00037	9	#10-24NC X 3/4"LG HHWF TYPE '23'
16	MAH00074	8	#8-32NC X 3/8"LG FHSCS SS
17	MBF00005	4	1/4" TYPE 'A' WIDE FLAT WASHER
18	MCK00017	1	3/8"DIA X 1-3/4"LG LOCK PIN
19	MDM00087	1	BALL BEARING
20	MDM00089	2	BALL BEARING
21	MJE00008	1	DIE SPRING

DRAWING REVISION HISTORY LISTING

PART NO: 433701

DESCRIPTION: PitBull® No. 14 FACER ASSEMBLY 100-120V, 50/60Hz, 1Ph

<u>APPR.</u>	<u>REV</u>	<u>DATE</u>	<u>BY</u>	<u>DESCRIPTION OF REVISION</u>
TMT	A	7/31/00	BWW	REVISED TO REMOVE ITEM #11 HOIST HANDLE. NEW STAND DOESN'T REQUIRE IT. CHANGED QTY OF ITEM #17 FROM 2 TO 4.
SWB	B	12/18/01	MLM	REVISED NOTE #1 LOCTITE FROM RC/601 TO #680, REMOVED PRIMER 'T' AND CURE TIME, ADDED CLEAN W/ SOLVENT & INSTALL WITH LOCTITE 680 TO AGREE WITH CURRENT ASSEMBLY PROCEDURES.MOVED NOTE #3 FOR WIRING MOTOR TO A424101 MOTOR ASSEMBLY DRAWING.
SWB	C	4/25/02	ALK	REVISED ITEM 15 MAH00037 DESCRIPTION FROM TYPE 'F' TO TYPE '23' TO INCREASE STRENGTH OF SCREW.
SWB	D	1/29/03	ALK	REVISED TO ADD FLAG NOTE #3 & NOTE 3. (HANDLE ONLY MAYBE ORDERED AS MJQ00060.) TO PARTS LIST.
SWB	E	06/01/05	BWW	CREATED ISOMETRIC VIEW FOR CLARITY. CHANGED ITEM 4 FROM 413702 TO 413701 QTY 4 TO MATCH PRODUCT STRUCTURE.