

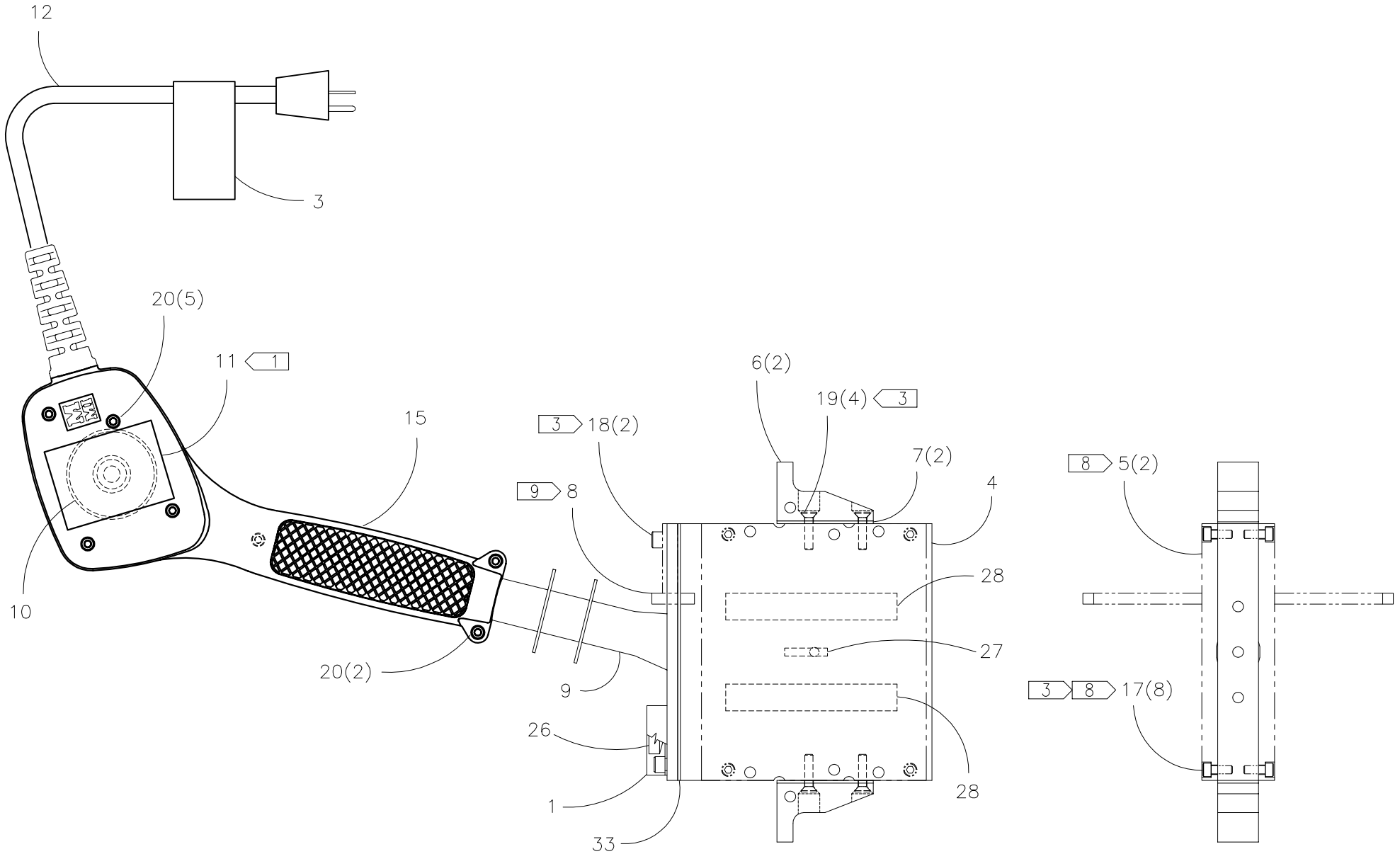

**McElroy Manufacturing, Inc.**  
 The leader by design.  
 Tulsa, Oklahoma U.S.A.

DRAWN: RLE	CHECK: TMT	APPRV'D: JRP	DATE: 3/11/02	DWG No: 424300	SHT No: 14A	REV No: C	PART No: 424314
#14 Pit Bull BUTT PLATE HEATER ASSEMBLY 200-240V, 50/60Hz, 1Ph							CAD No: 424314

NOTE: THIS DRAWING AND THE INFORMATION CONTAINED THEREIN IS THE CONFIDENTIAL AND PROPRIETARY PROPERTY OF McElroy Manufacturing, Inc. THE DRAWING IS NOT TO BE REPRODUCED IN ANY MANNER, SUBMITTED OUTSIDE PARTIES FOR EXAMINATION, OR USED DIRECTLY OR INDIRECTLY FOR THE PURPOSES OTHER THAN THOSE FOR WHICH IT WAS FURNISHED WITHOUT WRITTEN PERMISSION OF McElroy Manufacturing, Inc.





**McElroy Manufacturing, Inc.**  
The leader by design.  
Tulsa, Oklahoma U.S.A.

DRAWN: RLE	CHECK: TMT	APPR'D: JRP	DATE: 3/11/02	DWG No: 424300	SHT No: 14B	REV No: C	PART No: 424314
#14 Pit Bull BUTT PLATE HEATER ASSEMBLY 200-240V, 50/60Hz, 1Ph							CAD No: 424314

NOTE: THIS DRAWING AND THE INFORMATION CONTAINED THEREIN IS THE CONFIDENTIAL AND PROPRIETARY PROPERTY OF McElroy Manufacturing, Inc. THE DRAWING IS NOT TO BE REPRODUCED IN ANY MANNER, SUBMITTED OUTSIDE PARTIES FOR EXAMINATION, OR USED DIRECTLY OR INDIRECTLY FOR THE PURPOSES OTHER THAN THOSE FOR WHICH IT WAS FURNISHED WITHOUT WRITTEN PERMISSION OF McElroy Manufacturing, Inc.

240 VAC PLUG

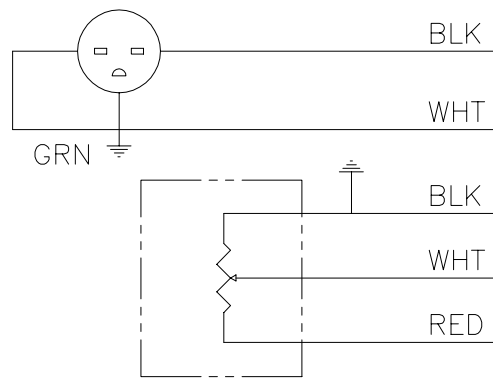

TEMP ADJUST

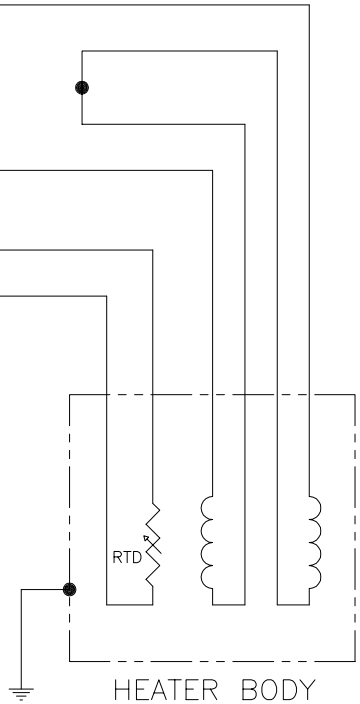
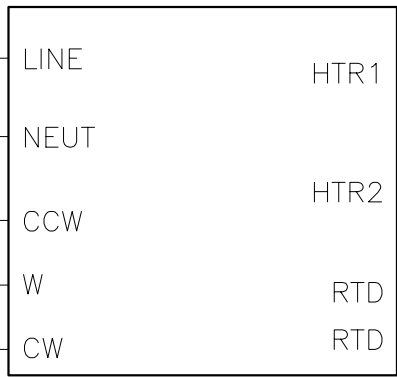

HEATER BODY

RTD LEADS  
POTENTIOMETER LEADS  
HEATER ELEMENT LEADS  
POWER LEADS

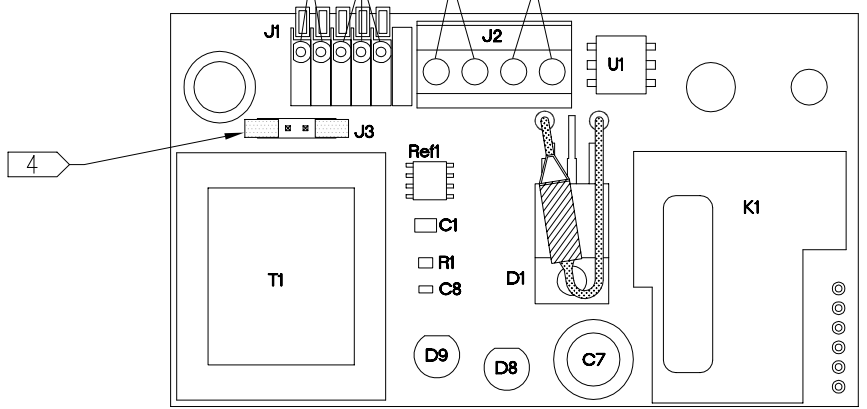

DETAIL ITEM -13 REF.

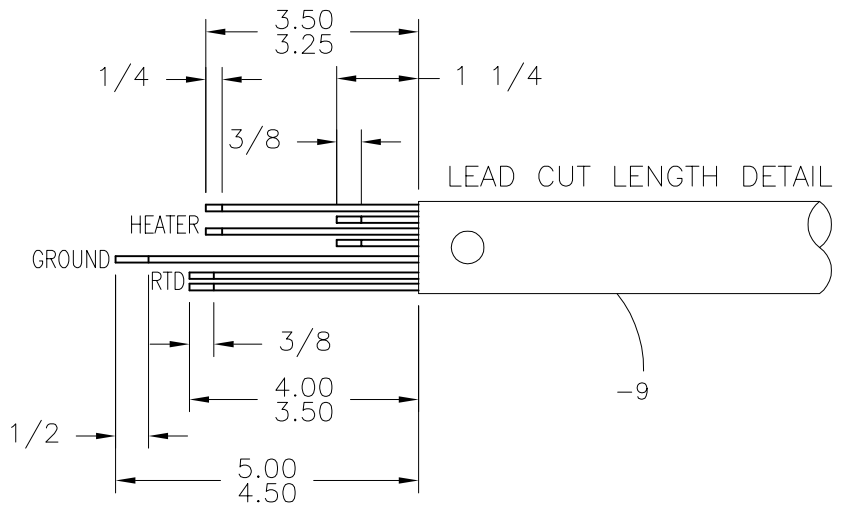



**McElroy Manufacturing, Inc.**  
 The leader by design.  
 Tulsa, Oklahoma U.S.A.

DRAWN: RLE	CHECK: TMT	APPRV'D: JRP	DATE: 3/11/02	DWG No: 424300	SHT No: 14C	REV No: C	PART No: 424314
#14 Pit Bull BUTT PLATE HEATER ASSEMBLY 200-240V, 50/60Hz, 1Ph							CAD No: 424314

NOTE: THIS DRAWING AND THE INFORMATION CONTAINED THEREIN IS THE CONFIDENTIAL AND PROPRIETARY PROPERTY OF McElroy Manufacturing, Inc. THE DRAWING IS NOT TO BE REPRODUCED IN ANY MANNER, SUBMITTED OUTSIDE PARTIES FOR EXAMINATION, OR USED DIRECTLY OR INDIRECTLY FOR THE PURPOSES OTHER THAN THOSE FOR WHICH IT WAS FURNISHED WITHOUT WRITTEN PERMISSION OF McElroy Manufacturing, Inc.

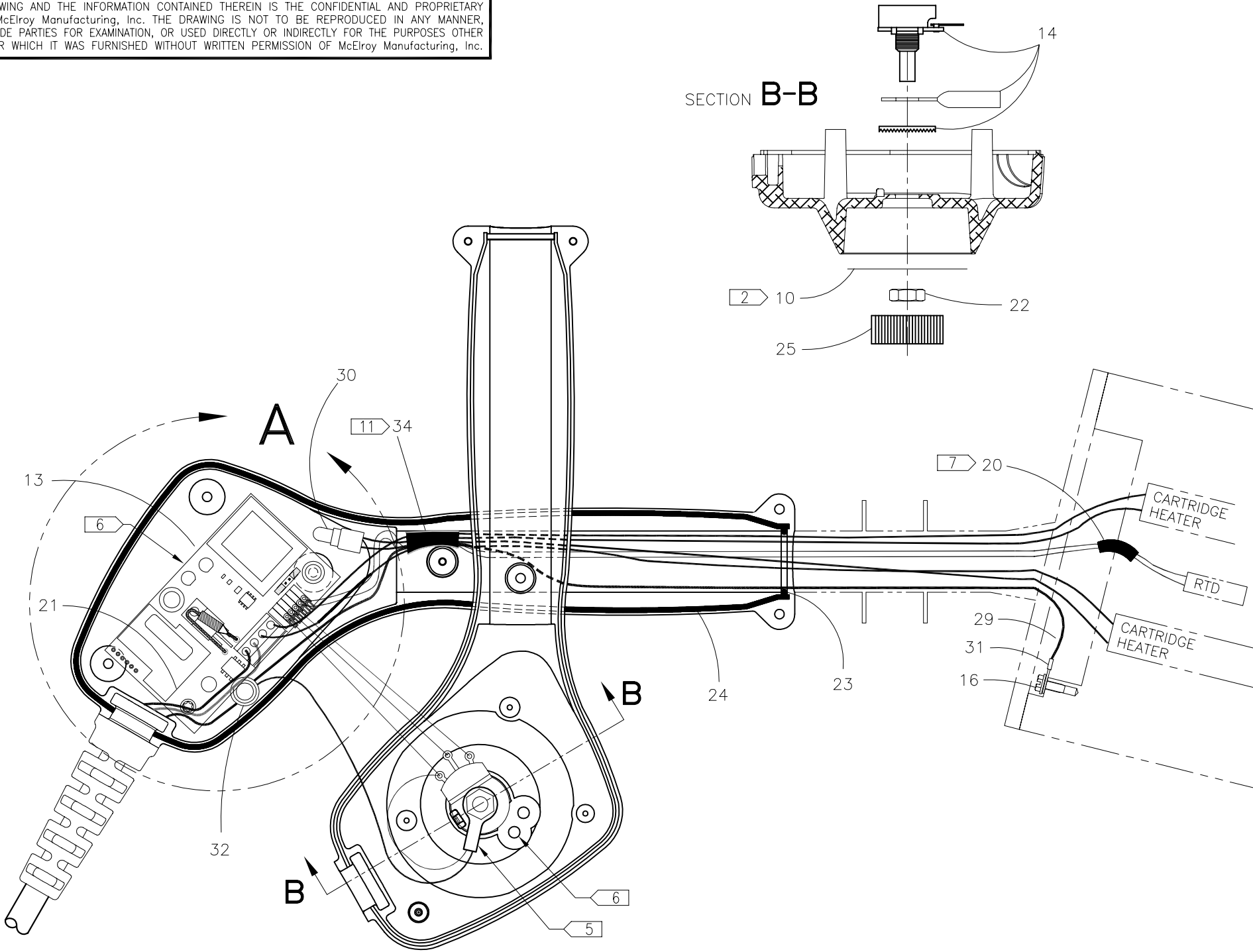



McElroy Manufacturing, Inc.  
The leader by design.  
Tulsa, Oklahoma U.S.A.

DRAWN: RLE	CHECK: TMT	APPRV'D: JRP	DATE: 3/11/02	DWG No: 424300	SHT No: 14D	REV No: C	PART No: 424314
#14 Pit Bull BUTT PLATE HEATER ASSEMBLY 200-240V, 50/60Hz, 1Ph							CAD No: 424314

NOTE: THIS DRAWING AND THE INFORMATION CONTAINED THEREIN IS THE CONFIDENTIAL AND PROPRIETARY PROPERTY OF McElroy Manufacturing, Inc. THE DRAWING IS NOT TO BE REPRODUCED IN ANY MANNER, SUBMITTED OUTSIDE PARTIES FOR EXAMINATION, OR USED DIRECTLY OR INDIRECTLY FOR THE PURPOSES OTHER THAN THOSE FOR WHICH IT WAS FURNISHED WITHOUT WRITTEN PERMISSION OF McElroy Manufacturing, Inc.

DETAIL TO SHOW HOW TO LAY WIRES INTO ENCLOSURE

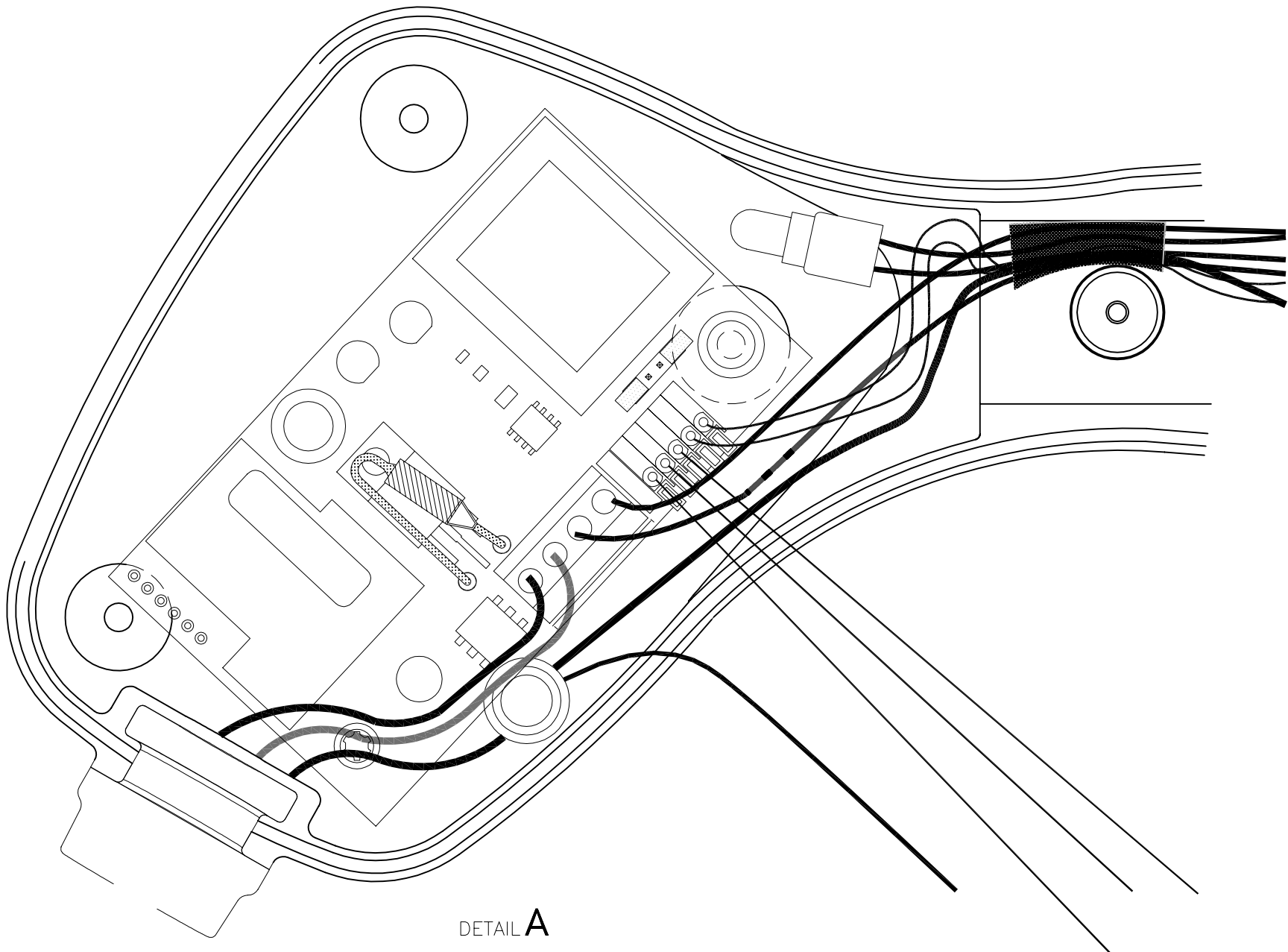

DETAIL A

**#14 Pit Bull BUTT PLATE HEATER ASSEMBLY  
200-240V, 50/60Hz, 1Ph**

Parts List

ITEM	PART NO.	QTY.	DESCRIPTION
	<b>424314</b>		<b>ASSEMBLY</b>
1	214801	1	Multi-Mc THERMAL GUARD
2	A424901	1	4" Multi-Mc HEATER SCREW & DRIVER KIT (NOT SHOWN)
3	410906	1	DANGER NOT EXPLOSION PROOF TAG LABEL
4	424402	1	HEATER BODY
5	424601	2	HEATER BUTT PLATE
6	425901	2	4" Multi-Mc HEATER SUPPORT BRACKET
7	426001	2	4" Multi-Mc HEATER SUPPORT BRACKET GASKET
8	432901	1	STRIPPER BAR WELDMENT
9	436001	1	HEATER COVER PLATE WELDMENT
10	816382	1	TEMPERATURE SCALE LABEL
11	816392	1	MODEL 424314 PART NO. LABEL
12	1854801	1	15AMP/250V POWER CORD
13	T5030001	1	HEATER CONTROL PCB ASSEMBLY
14	T5030002	1	POTENTIOMETER ASSEMBLY
15	T5030103	1	HEATER HANDLE/ENCLOSURE
16	MAH00036	1	#6-32NC x 3/8 LG. HWH TC SCREW
17	MAH00046	8	#10-24NC x 1/2 LG. SHCS SS
18	MAH00052	2	1/4-20NC x 3/4 LG. SHCS SS
19	MAH00105	4	#10-24NC x 3/4 LG. FHSCS SS
20	MAL00010	7	#6-19 x 3/4 LG. TORX T15 PAN HEAD SCREW
21	MAL00011	1	#6-19 x 1/4 LG. TORX T15 PAN HEAD SCREW
22	MBA00067	1	HEX SEAL NUT
23	MDL00018	1	O-RING
24	MDL00243	26IN	.070 DIA. BUNA-N O-RING STOCK
25	MJJ00023	1	CONTROL KNOB
26	MJK00001	1	5" LG., 150-750° F THERMOMETER
27	MKI00003	1	1 x 3/16 316SS 100 OHM PLATINUM RTD
28	MLD00011	2	120V, 600W, 5/8 x 4 CARTRIDGE HEATER
29	MLL00004	18IN	#18 TYPE TGGT ELECTRICAL WIRE
30	MLM00002	1	CRIMP ON WIRE JOINT
31	MLM00004	1	RING TERMINAL
32	MLM00010	1	CONNECTOR
33	436301	1	COVER PLATE GASKET
34	MLN00219	8IN	FIBERGLASS TAPE

**#14 Pit Bull BUTT PLATE HEATER ASSEMBLY**  
**200-240V, 50/60Hz, 1Ph**

Parts List

ITEM	PART NO.	QTY.	DESCRIPTION
------	----------	------	-------------

**NOTES:**

1. ITEM 11 SHOULD BE ORIENTED THE SAME AS THE MMI LOGO.
2. ITEM 10 MUST BE ORIENTED SO THE NOTCH ENGAGES THE KEY ON ITEM 15.
3. INSTALL WITH HIGH TEMPERATURE ANTI-SEIZE COMPOUND.
4. PLACE ONE JUMPER ON CENTER TWO PINS FOR 200-240V OPERATION.
5. RING TERMINAL MUST BE ORIENTED AS SHOWN.
6. WHEN MATING HALVES, MAKE SURE THE LED ON THE PC BOARD, ITEM 13, FITS INTO LONG SOCKET ON COVER.
7. SET AND CHECK TEMPERATURE PER SP-9.
8. THESE ITEMS ARE NOT PART OF THIS ASSEMBLY. ORDER A425201 BUTT PLATE REPLACEMENT KIT FOR THESE PARTS.
9. THIS ITEM IS NOT PART OF THIS ASSEMBLY. ORDER 432901 STRIPPER BAR FOR THIS PART.
10. USE PART NUMBER A424314 FOR TOTAL ASSEMBLY WHICH INCLUDES BUTT PLATES AND STRIPPER BAR.
11. TAPE WIRES IN AREA OF HANDLE BOSS TO PREVENT PINCHING AT ASSEMBLY.
12. TAPE RTD WIRES IN AREA OF RTD HOLE EXIT TO PREVENT CHAFFING.

## DRAWING REVISION HISTORY LISTING

**PART NO:** 424314

**DESCRIPTION:** #14 Pit Bull BUTT PLATE HEATER ASSEMBLY 200-240V, 50/60Hz, 1Ph

<u>APPR.</u>	<u>REV</u>	<u>DATE</u>	<u>BY</u>	<u>DESCRIPTION OF REVISION</u>
SWB	A	01/23/03	BWW	ADDED ITEM 34 MLN00219 WITH A QTY OF 8IN & ADDED NOTE 11 AND 12 FOR TAPING WIRES. ADDED LENGTH TOLERANCE TO LEAD CUT LENGTH DETAIL.
SWB	B	8/15/03	RLE	REVISED STRIP LENGTH ON RTD ONLY FROM 3/16 TO 3/8 TO MAKE COMPATIBLE WITH CONNECTOR USED ON REV. 'B' HEATER CONTROL PCB ASSEMBLY (T5030001) & UPDATED PICTURE OF HEATER CONTROL PCB ASSEMBLY.
SWB	C	10/27/03	BWW	CORRECTED PICTORIALY THE VIEW OF THE PCB BOARD ON SHT 14C AND 14D TO SHOW CURRENT DESIGN.