

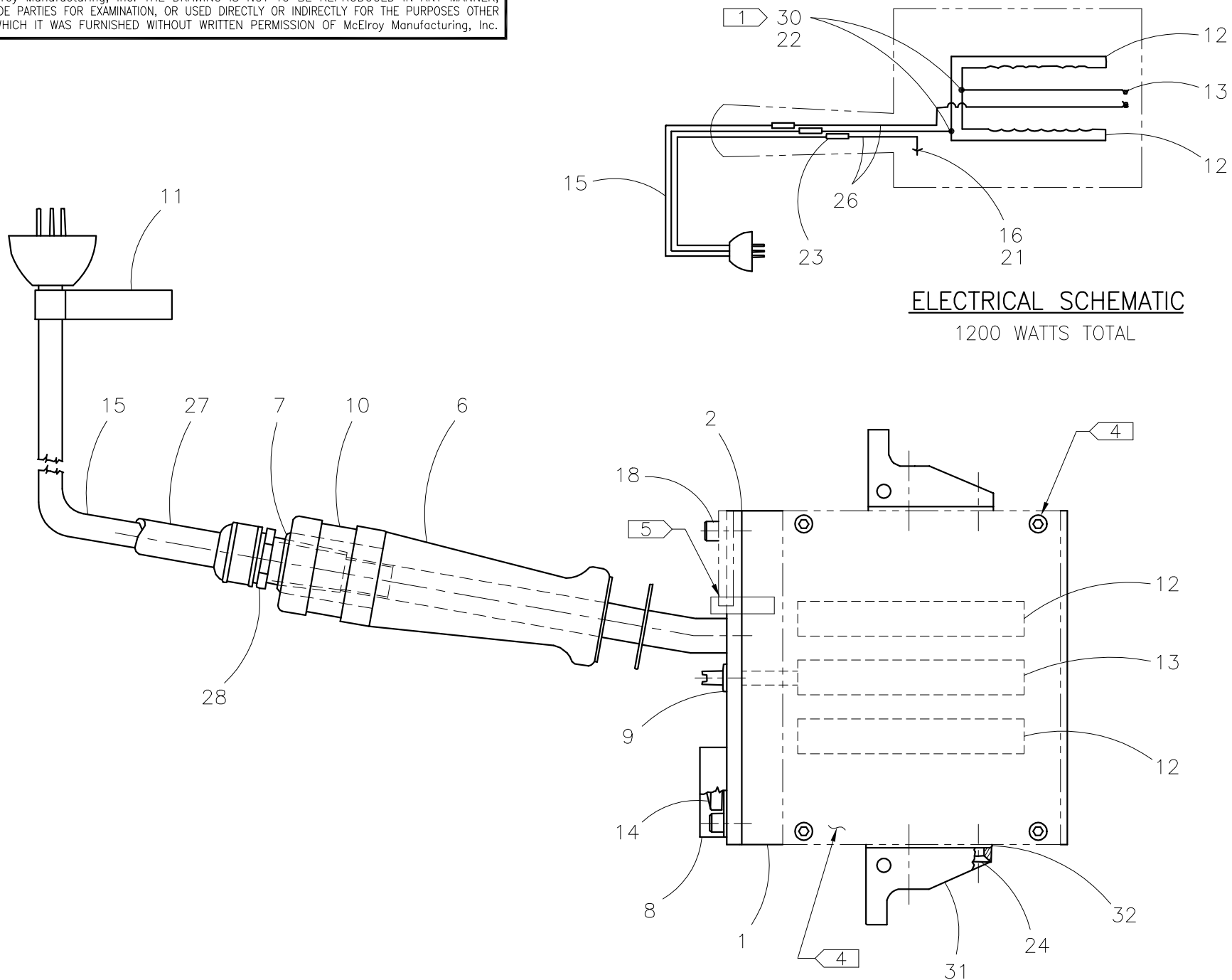

McElroy Manufacturing, Inc.
 The leader by design.
 Tulsa, Oklahoma U.S.A.

DRAWN: SWB	CHECK: BWP	APPRV'D: B	DATE: 5/16/95	DWG No: 424300	SHT No: 1	REV No: M	PART No: 424304
#14 Multi-Mc BUTT PLATE HEATER ASSEMBLY 100-120V, 50/60Hz, 1Ph							CAD No: 424304

NOTE: THIS DRAWING AND THE INFORMATION CONTAINED THEREIN IS THE CONFIDENTIAL AND PROPRIETARY PROPERTY OF McElroy Manufacturing, Inc. THE DRAWING IS NOT TO BE REPRODUCED IN ANY MANNER, SUBMITTED TO OUTSIDE PARTIES FOR EXAMINATION, OR USED DIRECTLY OR INDIRECTLY FOR THE PURPOSES OTHER THAN THOSE FOR WHICH IT WAS FURNISHED WITHOUT WRITTEN PERMISSION OF McElroy Manufacturing, Inc.



**#14 Multi-Mc BUTT PLATE HEATER ASSEMBLY
100-120V, 50/60 Hz, 1Ph**

PARTS LIST

ITEM	PART NO.	QTY	DESCRIPTION
	424304		ASSEMBLY
1	424402	1	HEATER BODY
2	428401	1	COVER PLATE WELDMENT
3			
4			
5			
6	414701	1	WOODEN HEATER HANDLE
7	415101	1	HEATER HANDLE THREADED ADAPTER
8	214801	1	MLMC THERMAL GUARD
9	215601	1	GROMMET
10	816354	1	MODEL 424304 PART NO. LABEL
11	410906	1	DANGER NOT EXPLOSION PROOF TAG LABEL
12	MLD00011	2	120V, 600W, 5/8 X 4 CARTRIDGE HEATER
13	MLC00007	1	100-600F, 10A-115V THERMOSWITCH
14	MJK00001	1	5 LG, 150-750 DEG F THERMOMETER
15	MLE00017	1	#16/3 ELEC CABLE ASSY X 20 FT
16	MAH00036	1	#6-32NC X 3/8 LG HWH TC SCR
17			
18	MAH00052	2	1/4-20NC X 3/4 LG SHCS 18-8 SS
19			
20			
21	MLM00004	1	#18-6 RING TERMINAL
22	MJQ00046	2	FERRULE
23	MLM00003	3	INSULATED BUTT SPLICE
24	MAH00105	4	#10-24NC X 3/4 LG FHSCS 18-8 SS
25			
26	MLL00004	12"	#18 TYPE TGGT ELEC WIRE
27	MHA00009	4"	3/8 ID X 9/16 OD AIR HOSE
28	MLK00007	1	STRAIN RELIEF CONNECTOR
29			
30	MLW00002	6"	FIBERGLASS SLEEVE
31	425901	2	HEATER SUPPORT BRACKET
32	426001	2	HEATER SUPPORT BRACKET GASKET
33			
34	A424901	1	4" Multi-Mc HEATER SCREW/DRIVER KIT

#14 Multi-Mc BUTT PLATE HEATER ASSEMBLY
100-120V, 50/60 Hz, 1Ph

PARTS LIST

ITEM	PART NO.	QTY	DESCRIPTION
------	----------	-----	-------------

NOTES:

1. USE SLEEVING (ITEM 30) TO COVER EXPOSED WIRING.
2. SPLICE LEADS IN HANDLE.
3. SET AND CHECK TEMPERATURE PER SP-9.
4. THESE ITEMS ARE NOT PART OF THIS ASSEMBLY, ORDER A425201 BUTT FUSION PLATE KIT FOR THESE PARTS.
5. THIS ITEM IS NOT PART OF THIS ASSEMBLY, ORDER 432901 STRIPPER BAR FOR THIS PART.
6. USE PART NO. A424304 FOR TOTAL ASSEMBLY WHICH INCLUDES BUTT PLATES AND STRIPPER BAR.
7. ITEM 34 NOT SHOWN ON DRAWING.

DRAWING REVISION HISTORY LISTING

PART NO: 424304

DESCRIPTION: #14 Multi-Mc BUTT PLATE HEATER ASSEMBLY 100-120V, 50/60Hz, 1Ph

<u>APPR.</u>	<u>REV</u>	<u>DATE</u>	<u>BY</u>	<u>DESCRIPTION OF REVISION</u>
B	F	7/24/95	TLW	Scanned & reduced to 'A' size format. Corrected parts list by adding Item 33. Del gasket #424801. MLW00002 was MLN00219.
B	G	11/21/95	TLW	CHANGE ITEM #2 424502 TO 428401. CHANGE ITEM #18 MAH00055 TO MAH00052.
SWB	H	1/17/97	DJL	CHANGED 120V TO 100-120V. CHANGED ITEM 10(P/N 410903) LABEL TO NEW LABEL(P/N 816354) TO SPECIFY VOLTAGE & WATTS. ADDED ITEM 11 (P/N 410906) EXPLOSION PROOF LABEL AT PLUG END OF POWER CORD. ITEM 22 P/N WAS MJQ00026.
TLW	J	2/4/98	TGW	DELETED ITEM 3 (P/N 424601), ITEM 4 (P/N 424702), ITEM 17 (P/N MAH00046), ITEM 19 (P/N MAH00045) & ITEM 20 (P/N MBB00005). ADDED ITEM 34 (P/N A424901) & NOTE #7.
TLW	K	11/10/98	TGW	DELETED ITEM 33 HELICOIL (MJM00015).
TMT	L	8/1/00	BWW	REVISED PICTURE AND NOTE 5 FROM A425302 SIDE MOUNT STRIPPER BAR KIT TO 432901 TOP MOUNT STRIPPER BAR. THIS IS COMPATIBLE WITH #14 Pit Bull AND ALL PREVIOUS #14 MACHINES.
SWB	M	9/20/00	DWK	STAGGERED POSITIONS OF BUTT SPLICES (ITEM 23) AND ELIMINATED SLEEVING (ITEM 30) FROM BUTT SPLICES TO MATCH AS-BUILT CONDITIONS.