

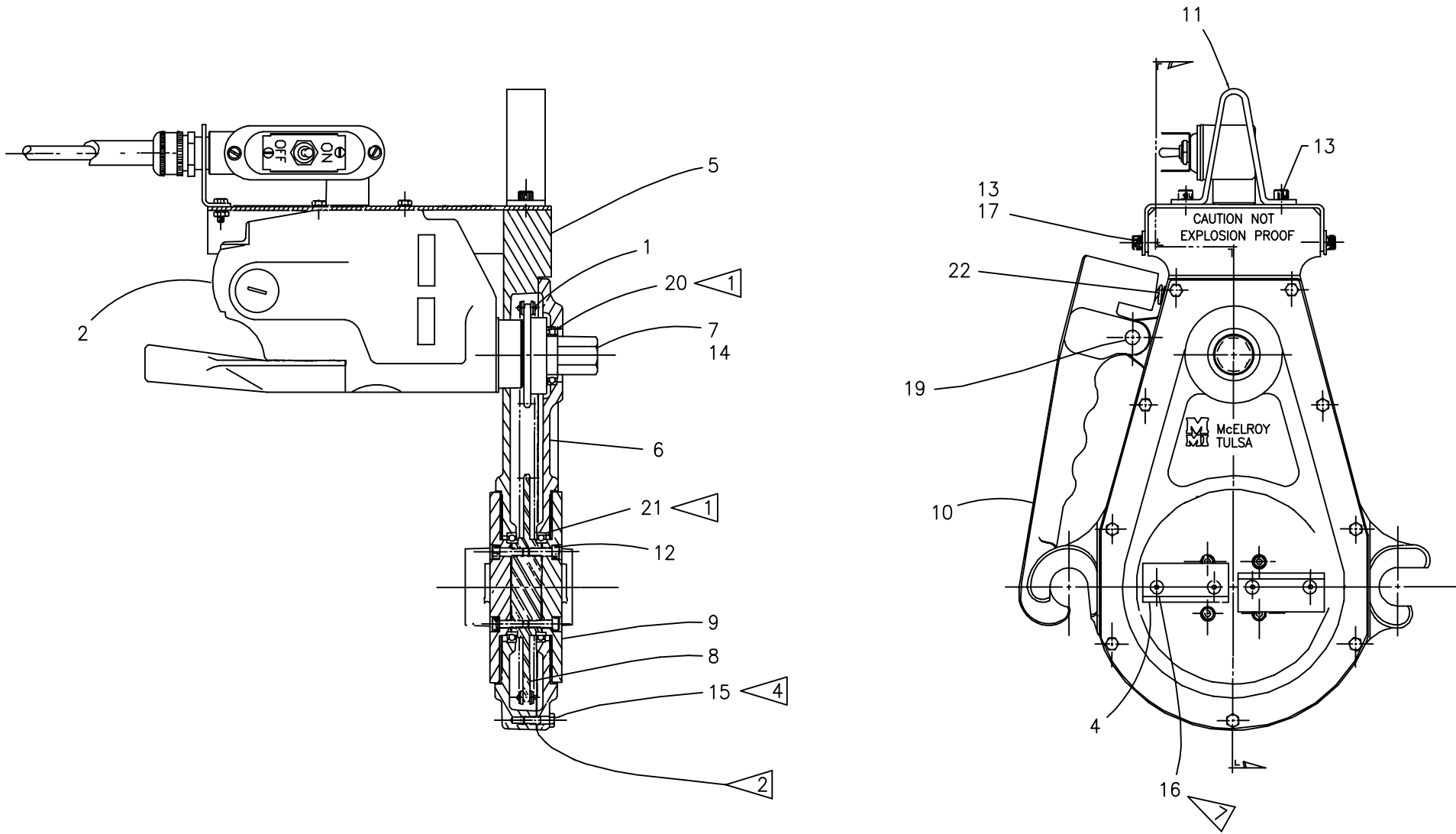

McElroy Manufacturing, Inc.
 The leader by design.
 Tulsa, Oklahoma U.S.A.

DRAWN: SWB	CHECK: BWP	APPRV'D: JMC	DATE: 5/16/95	DWG No: 401000	SHT No: 1	REV No: W	PART No: 401001
#14 FACER ASSEMBLY 100-120V, 50/60Hz, 1Ph							CAD No: 401001

NOTE: THIS DRAWING AND THE INFORMATION CONTAINED THEREIN IS THE CONFIDENTIAL AND PROPRIETARY PROPERTY OF McElroy Manufacturing, Inc. THE DRAWING IS NOT TO BE REPRODUCED IN ANY MANNER, SUBMITTED OUTSIDE PARTIES FOR EXAMINATION, OR USED DIRECTLY OR INDIRECTLY FOR THE PURPOSES OTHER THAN THOSE FOR WHICH IT WAS FURNISHED WITHOUT WRITTEN PERMISSION OF McElroy Manufacturing, Inc.



#14 FACER ASSEMBLY
100-120V, 50/60Hz, 1Ph

PARTS LIST

ITEM	PART NO.	QTY.	DESCRIPTION
	401001		Assembly
1	A422701	1	FACER CHAIN ASSEMBLY
2	A424101	1	FACER MOTOR ASS'Y
3			
4	413702	1	BLADE SET
5	417002	1	FACER BODY
6	417102	1	FACER COVER
7	417202	1	DRIVER SPROCKET WELDMENT
8	417301	1	DRIVEN SPROCKET
9	417401	2	BLADE HOLDER
10	433002	1	LATCH HANDLE
11	815902	1	HOIST HANDLE
12	MAC00037	8	#10-24NC X 5/8"LG SHCS STL BL
13	MAC00051	4	1/4-20NC X 1/2"LG SHCS STL BL
14	MAC00065	1	1/4-20NC X 1-1/2"LG L/H SHCS STL
15	MAH00037	9	#10-24NC X 3/4"LG HWH TYPE '23'
16	MAH00074	8	#8-32NC X 3/8"LG FHSCS 18-8SS
17	MBF00005	2	1/4" TYPE 'A' WIDE FLT WASHER
18			
19	MCK00017	1	3/8"DIA X 1-3/4"LG LOCK PIN ST
20	MDM00087	1	BALL BEARING
21	MDM00089	2	BALL BEARING
22	MJE00008	1	DIE SPRING

NOTES:

1. On outer race only, clean with solvent, assemble with Loctite #680 and cure one hour.
2. Use Permatex #2C Non-Hardening sealant at joint common to facer body & cover.
3. Wire motor for counter-clockwise rotation facing shaft end of motor.
4. Install screws using 40-45 psi air pressure and a thread lube.
- 5.
6. Add high temperature grease to inside cavity.
7. Install with C5-A high temp anti-seize lubricant.
8. Spray surfaces that contact guide rod with DOW 557 silicone dry film lubricant. Allow it to dry to touch before assembly

DRAWING REVISION HISTORY LISTING

PART NO: 401001

DESCRIPTION: #14 FACER ASSEMBLY 100-120V, 50/60Hz, 1Ph

<u>APPR.</u>	<u>REV</u>	<u>DATE</u>	<u>BY</u>	<u>DESCRIPTION OF REVISION</u>
JMC	P	5/16/95	SWB	Scanned & reduced to 'A' size format.
B	Q	9/03/95	TLW	Removed item #16(label)
JMC	R	4/03/96	SWB	Removed item #8 (417601) gasket. Replaced note 2 to use Permatex as a gasket. Added note 8 to BOM.
SWB	S	12/11/96	SS	CHANGED 120V TO 100-120V. RE-NUMBERED DRAWING AND BOM TO CLEAN UP
TLW	T	2/3/98	TGW	REMOVED ITEM #18 MCG00005 ROLL PIN. NOT NECESSARY FOR ASSEMBLY.
TLW	U	5/28/98	TGW	REMOVED ITEM #3 LABEL (410902).
SWB	V	9/29/00	DWK	REVISED NOTE 1 TO LOCTITE 680 AND CLEAN WITH SOLVENT INSTEAD OF PRIMER 'T', AND REVISED NOTE 6 ADD HIGH TEMP GREASE TO INSIDE CAVITY. REMOVED NOTE 5. THESE CHANGES MADE TO MATCH AS BUILT CONDITIONS.
MLM	-	03/27/01	BWW	REVISED ITEM #10 417702 TO 433002 TO USE NEW DESIGN.
SWB	W	5/1/02	ALK	REVISED ITEM 15 MAH00037 DESCRIPTION FROM TYPE 'F' TO TYPE '23' TO INCREASE STRENGTH OF SCREW.