

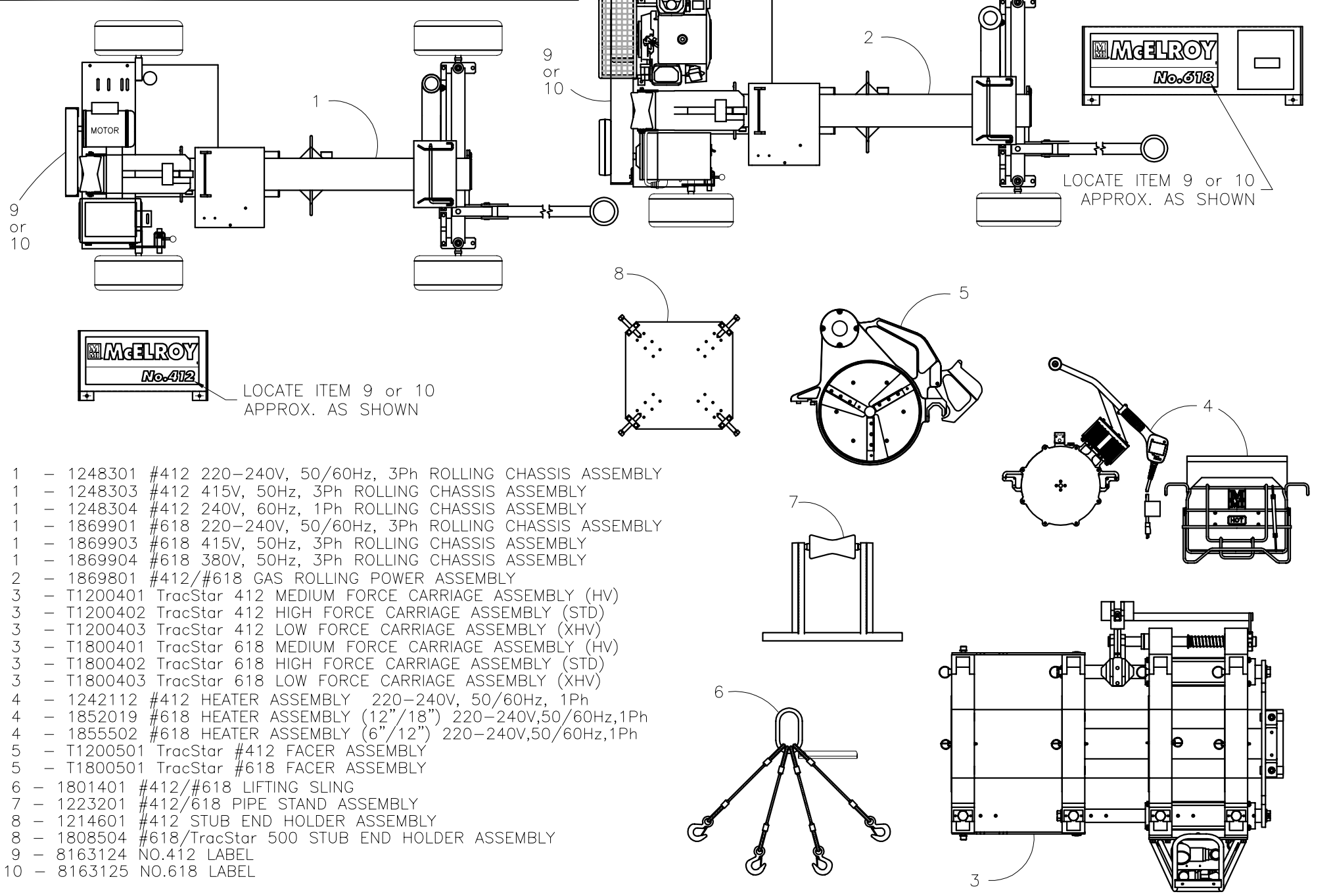

McElroy Manufacturing, Inc.
 The leader by design.
 Tulsa, Oklahoma U.S.A.

DRAWN: RLE	CHECK: BLM	APPRV'D: SWB	DATE: 7/28/03	DWG No:	SHT No:	REV No: D	PART No:
#412/#618 FUSION MACHINE GROUPING FOR 1248100 & 1869100 ASSEMBLIES							CAD No: _ASSY1218T

NOTE: THIS DRAWING AND THE INFORMATION CONTAINED THEREIN IS THE CONFIDENTIAL AND PROPRIETARY PROPERTY OF McElroy Manufacturing, Inc. THE DRAWING IS NOT TO BE REPRODUCED IN ANY MANNER, SUBMITTED OUTSIDE PARTIES FOR EXAMINATION, OR USED DIRECTLY OR INDIRECTLY FOR THE PURPOSES OTHER THAN THOSE FOR WHICH IT WAS FURNISHED WITHOUT WRITTEN PERMISSION OF McElroy Manufacturing, Inc.



- 1 - 1248301 #412 220-240V, 50/60Hz, 3Ph ROLLING CHASSIS ASSEMBLY
- 1 - 1248303 #412 415V, 50Hz, 3Ph ROLLING CHASSIS ASSEMBLY
- 1 - 1248304 #412 240V, 60Hz, 1Ph ROLLING CHASSIS ASSEMBLY
- 1 - 1869901 #618 220-240V, 50/60Hz, 3Ph ROLLING CHASSIS ASSEMBLY
- 1 - 1869903 #618 415V, 50Hz, 3Ph ROLLING CHASSIS ASSEMBLY
- 1 - 1869904 #618 380V, 50Hz, 3Ph ROLLING CHASSIS ASSEMBLY
- 2 - 1869801 #412/#618 GAS ROLLING POWER ASSEMBLY
- 3 - T1200401 TracStar 412 MEDIUM FORCE CARRIAGE ASSEMBLY (HV)
- 3 - T1200402 TracStar 412 HIGH FORCE CARRIAGE ASSEMBLY (STD)
- 3 - T1200403 TracStar 412 LOW FORCE CARRIAGE ASSEMBLY (XHV)
- 3 - T1800401 TracStar 618 MEDIUM FORCE CARRIAGE ASSEMBLY (HV)
- 3 - T1800402 TracStar 618 HIGH FORCE CARRIAGE ASSEMBLY (STD)
- 3 - T1800403 TracStar 618 LOW FORCE CARRIAGE ASSEMBLY (XHV)
- 4 - 1242112 #412 HEATER ASSEMBLY 220-240V, 50/60Hz, 1Ph
- 4 - 1852019 #618 HEATER ASSEMBLY (12"/18") 220-240V,50/60Hz,1Ph
- 4 - 1855502 #618 HEATER ASSEMBLY (6"/12") 220-240V,50/60Hz,1Ph
- 5 - T1200501 TracStar #412 FACER ASSEMBLY
- 5 - T1800501 TracStar #618 FACER ASSEMBLY
- 6 - 1801401 #412/#618 LIFTING SLING
- 7 - 1223201 #412/618 PIPE STAND ASSEMBLY
- 8 - 1214601 #412 STUB END HOLDER ASSEMBLY
- 8 - 1808504 #618/TracStar 500 STUB END HOLDER ASSEMBLY
- 9 - 8163124 NO.412 LABEL
- 10 - 8163125 NO.618 LABEL

DRAWING REVISION HISTORY LISTING

PART NO: _ASSY1218T

DESCRIPTION: #412/#618 FUSION MACHINE GROUPING FOR 1248100 & 1869100 ASSEMBLIES

<u>APPR.</u>	<u>REV</u>	<u>DATE</u>	<u>BY</u>	<u>DESCRIPTION OF REVISION</u>
SWB	A	12/2/03	ALK	REVISED TO ADD 1870001 #618 ELECTRIC ASSY. 380V, 50Hz, 3Ph
SWB	B	3/3/04	MLM	REVISED CONFIGURATIONS BY CREATING SEPARATE DWGS FOR EACH MOTOR WITH ROLLING CHASSIS. MOVED SCHEMATICS TO ROLLING CHASSIS REMOVED 220V CONFIGURATIONS & REVISED DESCRIPTIONS OF 240V CONFIGURATIONS TO DUAL VOLTAGE FOR CONSOLIDATION.
SWB	C	1/5/05	MLM	REVISED TO ADD 1248304 #412 240V, 60Hz, 1Ph CHASSIS.
SWB	D	01/06/05	BWW	ADDED ITEM 9 8163124 AND ITEM 10 8163125 AND DETAILS TO LOCATE LABELS.