



**McElroy Manufacturing, Inc.**  
 The leader by design.  
 Tulsa, Oklahoma U.S.A.

DRAWN: BWW	CHECK: TMT	APPRV'D: JRP	DATE: 04/05/02	SHT No: 12	REV No: F	PART No: 1242112
------------	------------	--------------	----------------	------------	-----------	------------------

#412 HEATER ASSEMBLY 220-240V, 50/60Hz, 1Ph

NOTE: THIS DRAWING AND THE INFORMATION CONTAINED THEREIN IS THE CONFIDENTIAL AND PROPRIETARY PROPERTY OF McElroy Manufacturing, Inc. THE DRAWING IS NOT TO BE REPRODUCED IN ANY MANNER, SUBMITTED OUTSIDE PARTIES FOR EXAMINATION, OR USED DIRECTLY OR INDIRECTLY FOR THE PURPOSES OTHER THAN THOSE FOR WHICH IT WAS FURNISHED WITHOUT WRITTEN PERMISSION OF McElroy Manufacturing, Inc.

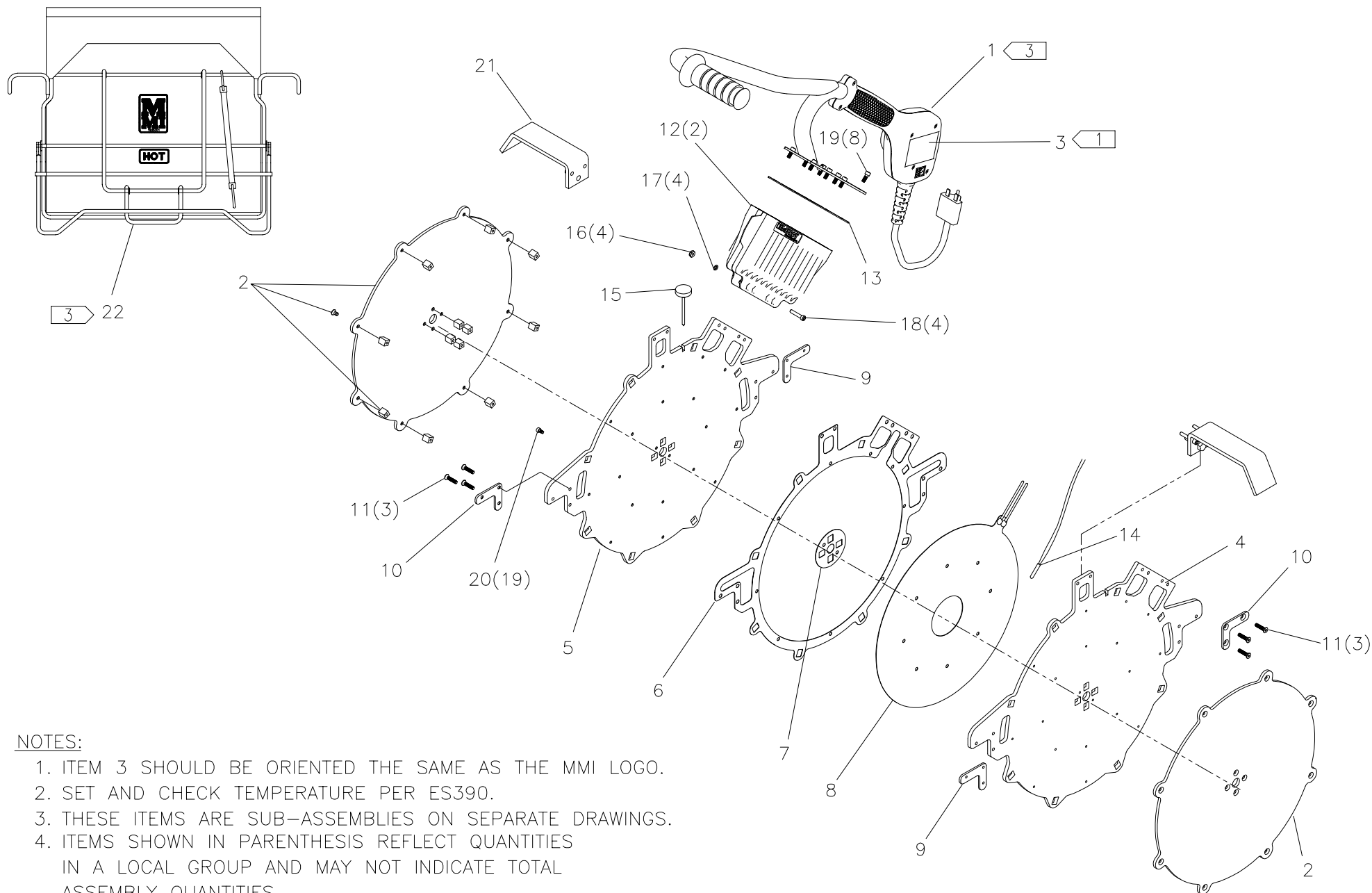

NOTES:

- ITEM 3 SHOULD BE ORIENTED THE SAME AS THE MMI LOGO.
- SET AND CHECK TEMPERATURE PER ES390.
- THESE ITEMS ARE SUB-ASSEMBLIES ON SEPARATE DRAWINGS.
- ITEMS SHOWN IN PARENTHESIS REFLECT QUANTITIES IN A LOCAL GROUP AND MAY NOT INDICATE TOTAL ASSEMBLY QUANTITIES.

**#412 HEATER ASSEMBLY 220-240V, 50/60Hz, 1Ph**Parts List

ITEM	PART NO.	QTY.	DESCRIPTION
	<b>1242112</b>		<b>ASSEMBLY</b>
1	1862601	1	8"-18" 220-240V, 50/60Hz, 1Ph HEATER HANDLE/CONTROLLER ASSEMBLY
2	A1242108	1	12 HEATER BUTT PLATE KIT
3	816395	1	MODEL 1242112 PART NO. LABEL
4	1242103	1	RIGHT HEATER BODY
5	1242104	1	LEFT HEATER BODY
6	1242105	1	HEATER O.D. SPACER
7	1242106	1	HEATER I.D. SPACER
8	1242201	1	240V MICA/FOIL HEATER ELEMENT
9	1852011	2	HEATER GUIDE ROD SUPPORT BRACKET
10	1852012	2	HEATER GUIDE ROD SUPPORT BRACKET
11	MAN00036	6	#10-32NF X 7/8" LG FHSCS SS
12	1863102	2	HEATER TERMINAL ENCLOSURE HALF
13	1808102	1	HEATER GASKET
14	MKI00003	1	100 OHM PLATINUM RTD
15	MJK00002	1	THERMOMETER
16	MBA00004	4	#10-24NC FINISHED HEX NUT
17	MBE00004	4	#10 REGULAR SPLIT LOCK WASHER
18	MAN00008	4	#10-24NC X 1" LG SHCS SS
19	MAH00046	8	#10-24NC X 1/2" LG SHCS SS
20	MAN00023	19	#8-32NC X 5/16" LG SHCS SS
21	A1242107	1	HEATER STRIPPER BAR KIT
22	1234202	1	HEATER BAG ASSEMBLY

## DRAWING REVISION HISTORY LISTING

**PART NO:** 1242112  
**DESCRIPTION:** #412 HEATER ASSEMBLY 220-240V, 50/60Hz, 1Ph

<u>APPR.</u>	<u>REV</u>	<u>DATE</u>	<u>BY</u>	<u>DESCRIPTION OF REVISION</u>
SWB	A	04/28/03	BWW	ADDED ITEM 48 MLN00219 WITH A QTY OF 4IN & ADDED NOTE 7 FOR TAPING WIRES. ADDED LENGTH TOLERANCE TO LEAD CUT LENGTH DETAIL. UPDATED PICTORIALY ITEM 30 TO NEW DESIGN WHICH WAS IMPLEMENTED MARCH 2003.
SWB	B	8/15/03	RLE	REVISED STRIP LENGTH ON RTD ONLY FROM 3/16 TO 3/8 TO MAKE COMPATIBLE WITH CONNECTOR USED ON REV. 'B' HEATER CONTROL PCB ASSEMBLY (T5030001) & UPDATED PICTURE OF HEATER CONTROL PCB ASSEMBLY.
SWB	C	10/27/03	BWW	CORRECTED PICTORIALY THE VIEW OF THE PCB BOARD ON SHT 12C AND 12D TO SHOW CURRENT DESIGN.
SWB	D	03/17/04	ALK	REVISED DRAWING TO REMOVED ITEMS 2 MAC00095, 7 MBA00007, 9 MBE00007, 17 1207302, 26 1810902, & 27 1852008. ADDED ITEM 49 1863102 QTY 2. CHANGES MADE TO IMPLEMENT USE OF DIE CAST TERMINAL ENCLOSURE.
WBD	E	3/22/04	ALK	REMOVED ITEMS #13 1852017 & #14 1852018, REVISED TO REMOVE UNNECESSARY SHIMS.
SWB	F	08/02/05	BWW	REVISED PICTORIALY TO SHOW EXPLODED ISOMETRIC VIEW ON SHT 12 & CONSOLIDATED ALL TO 1 SHEET. ADDED 1862601 HANDLE ASSEMBLY. REMOVED THE FOLLOWING ITEMS: 3 MAH00030, 10 MJJ00009, 15 1854801, 16 MDL00243, 30 838007, 31 410906, 34 816382, 36 T5030103, 37 T5030001, 38 T5030002, 39 MBA00067, 40 MJJ00023, 41 MLM00010, 42 MLM00024, 43 MAL00010, 44 MAL00011, 45 MDL00018, 46 MLL00025, 47 MBG00072 AND 48 MLN00219 WHICH WERE CONSOLIDATED IN 1862601.



McElroy Manufacturing, Inc.

The leader by design.

Tulsa, Oklahoma U.S.A.

DRAWN: BWW

CHECK: TMT

APPRV'D: SWB

DATE: 06/14/02

DWG No: 1862600

SHT No: 1A

REV No: C

PART No: 1862601

8"-18" 220-240V,50/60Hz,1Ph HEATER HANDLE/CONTROLLER ASSEMBLY

CAD No: 1862601

NOTE: THIS DRAWING AND THE INFORMATION CONTAINED THEREIN IS THE CONFIDENTIAL AND PROPRIETARY PROPERTY OF McElroy Manufacturing, Inc. THE DRAWING IS NOT TO BE REPRODUCED IN ANY MANNER, SUBMITTED OUTSIDE PARTIES FOR EXAMINATION, OR USED DIRECTLY OR INDIRECTLY FOR THE PURPOSES OTHER THAN THOSE FOR WHICH IT WAS FURNISHED WITHOUT WRITTEN PERMISSION OF McElroy Manufacturing, Inc.

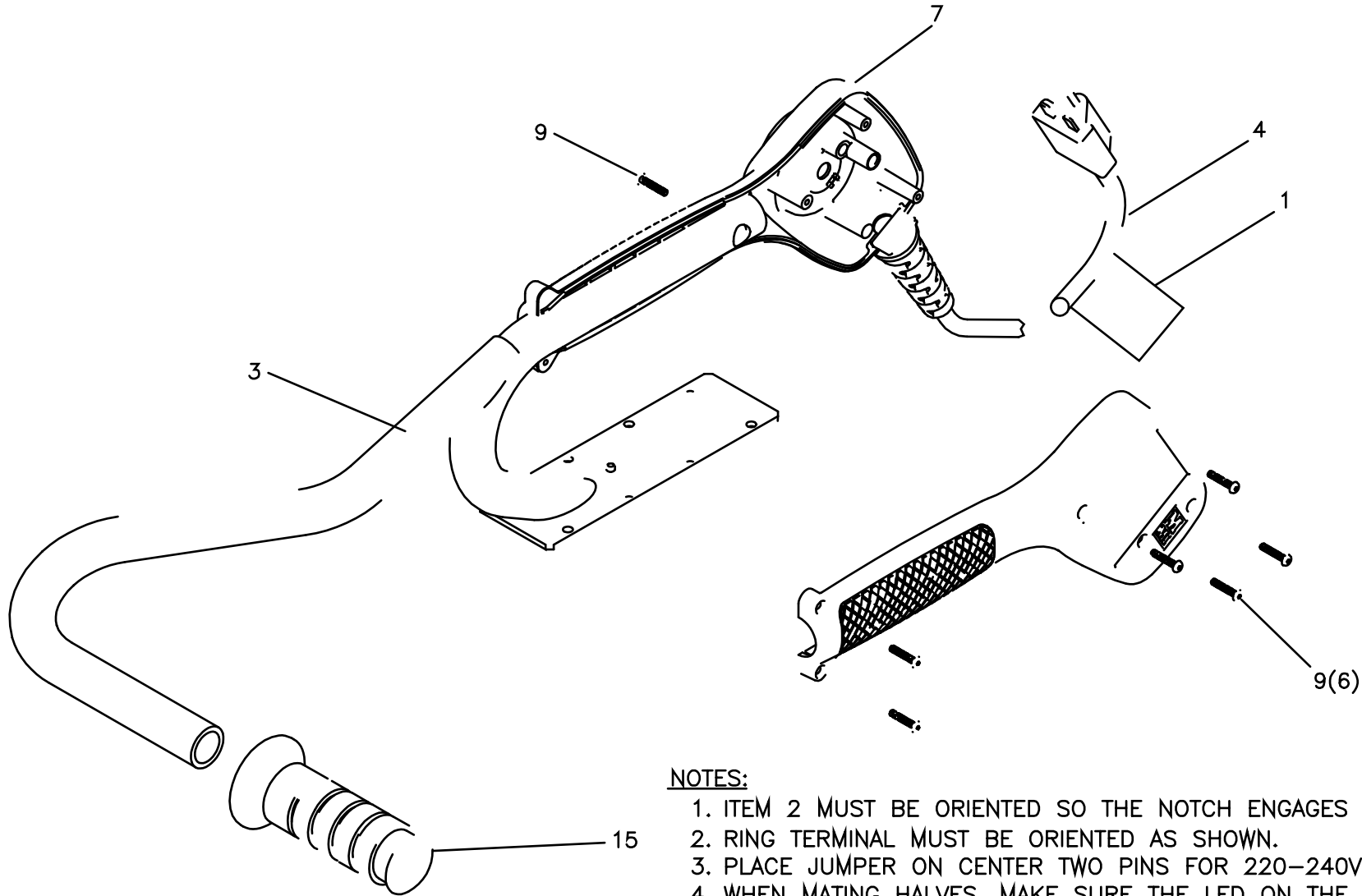

NOTES:

1. ITEM 2 MUST BE ORIENTED SO THE NOTCH ENGAGES THE KEY ON ITEM 7.
2. RING TERMINAL MUST BE ORIENTED AS SHOWN.
3. PLACE JUMPER ON CENTER TWO PINS FOR 220-240V OPERATION.
4. WHEN MATING HALVES, MAKE SURE THE LED ON THE PC BOARD FITS INTO LONG SOCKET ON COVER.
5. TAPE WIRES IN AREA SHOWN TO PREVENT DAMAGE.
6. PAINT THIS WIRE WITH HIGH TEMP GREEN PAINT TO MARK AS GROUND WIRE.
7. ITEMS SHOWN IN PARENTHESIS REFLECT QUANTITIES IN A LOCAL GROUP AND MAY NOT INDICATE TOTAL ASSEMBLY QUANTITIES.



**McElroy Manufacturing, Inc.**  
 The leader by design.  
 Tulsa, Oklahoma U.S.A.

DRAWN: BWW	CHECK: TMT	APPRV'D: SWB	DATE: 06/14/02	DWG No: 1862600	SHT No: 1B	REV No: C	PART No: 1862601
8"-18" 220-240V,50/60Hz,1Ph HEATER HANDLE/CONTROLLER ASSEMBLY							CAD No: 1862601

NOTE: THIS DRAWING AND THE INFORMATION CONTAINED THEREIN IS THE CONFIDENTIAL AND PROPRIETARY PROPERTY OF McElroy Manufacturing, Inc. THE DRAWING IS NOT TO BE REPRODUCED IN ANY MANNER, SUBMITTED OUTSIDE PARTIES FOR EXAMINATION, OR USED DIRECTLY OR INDIRECTLY FOR THE PURPOSES OTHER THAN THOSE FOR WHICH IT WAS FURNISHED WITHOUT WRITTEN PERMISSION OF McElroy Manufacturing, Inc.

240 VAC PLUG

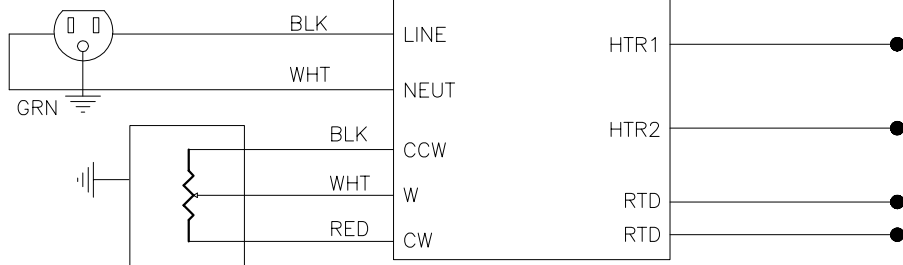

TEMP ADJUST

SECTION A-A

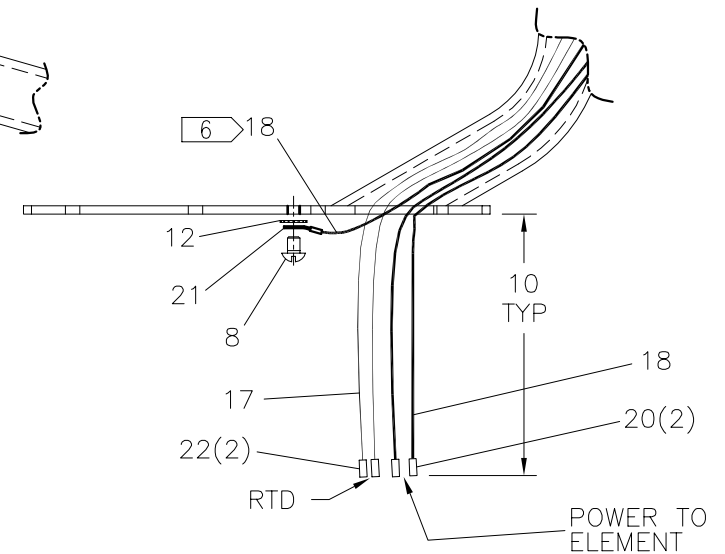
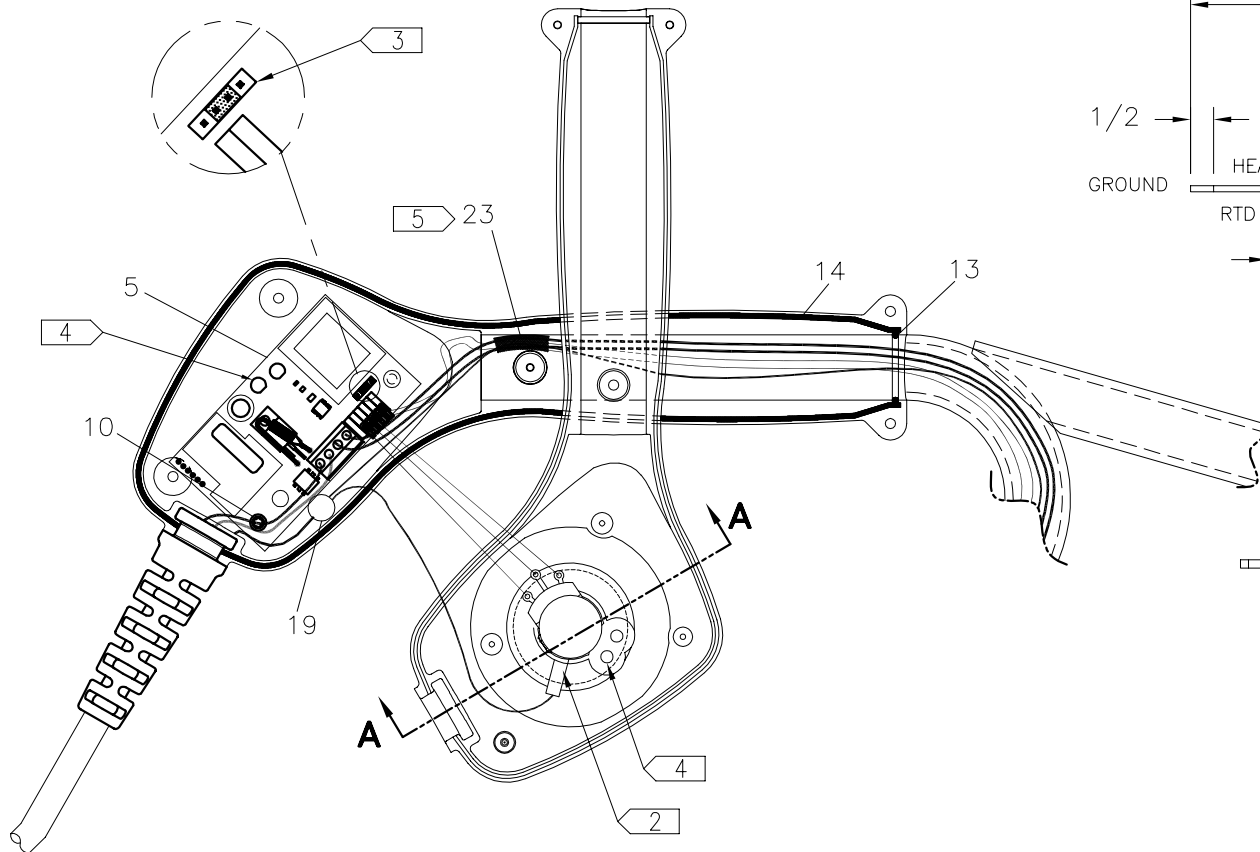
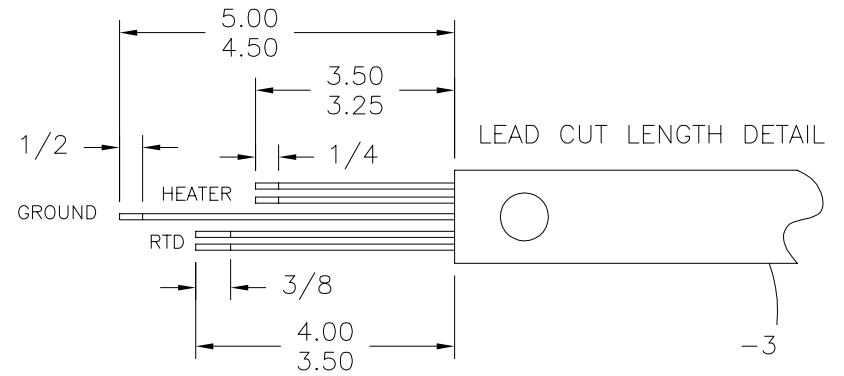
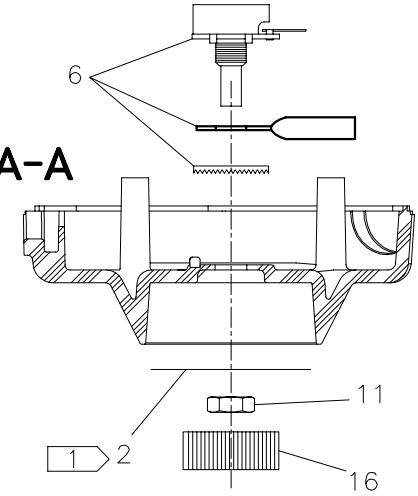

**8"-18" 220-240V, 50/60Hz, 1Ph HEATER  
HANDLE/CONTROLLER ASSEMBLY**

Parts List

ITEM	PART NO.	QTY.	DESCRIPTION
	<b>1862601</b>		<b>ASSEMBLY</b>
1	410906	1	DANGER NOT EXPLOSION PROOF TAG LABEL
2	816382	1	TEMPERATURE SCALE LABEL
3	838007	1	HEATER HANDLE WELDMENT
4	1854801	1	15AMP/250V POWER CORD
5	T5030001	1	HEATER CONTROL PCB ASSEMBLY
6	T5030002	1	POTENTIOMETER ASSEMBLY
7	T5030103	1	HEATER HANDLE/ENCLOSURE
8	MAH00030	1	#10-24NC X 1/4 LG RHSMS
9	MAL00010	7	#6-19 x 3/4LG TORX T15 PAN HEAD SCREW
10	MAL00011	1	#6-19 x 1/4LG TORX T15 PAN HEAD SCREW
11	MBA00067	1	HEX SEAL NUT
12	MBG00072	1	#10 INTERNAL TOOTHED LOCK WASHER
13	MDL00018	1	O-RING
14	MDL00243	26IN	.070 DIA. BUNA-N O-RING STOCK
15	MJJ00009	1	BLACK HAND GRIP
16	MJJ00023	1	CONTROL KNOB
17	MLL00004	60IN	#18 TYPE TGGT ELECTRICAL WIRE
18	MLL00025	84IN	#12 TYPE TGGT ELECTRICAL WIRE
19	MLM00010	1	CONNECTOR
20	MLM00180	2	10-12 HI-TEMP BUTT SPLICE
21	MLM00024	1	RING TERMINAL
22	MLM00040	2	CONNECTOR
23	MLN00219	4IN	FIBERGLASS TAPE

## DRAWING REVISION HISTORY LISTING

**PART NO:** 1862601

**DESCRIPTION:** 8"-18" 220-240V, 50/60Hz, 1Ph HEATER HANDLE/CONTROLLER ASSEMBLY

<u>APPR.</u>	<u>REV</u>	<u>DATE</u>	<u>BY</u>	<u>DESCRIPTION OF REVISION</u>
SWB	A	04/28/03	BWW	ADDED ITEM 24 MLN00219 WITH A QTY OF 4IN & ADDED NOTE 6 FOR TAPING WIRES. ADDED LENGTH TOLERANCE TO LEAD CUT LENGTH DETAIL. UPDATED PICTORIALY ITEM 3 TO NEW DESIGN WHICH WAS IMPLEMENTED MARCH 2003.
SWB	B	8/18/03	RLE	REVISED STRIP LENGTH ON RTD ONLY FROM 3/16 TO 3/8 TO MAKE COMPATIBLE WITH CONNECTOR USED ON REV. 'B' HEATER CONTROL PCB ASSEMBLY (T5030001) & UPDATED PICTURE OF HEATER CONTROL PCB ASSEMBLY.
SWB	C	08/02/05	BWW	REVISED PICTORIALY TO SHOW EXPLODED ISOMETRIC VIEW ON SHT 1A & CONSOLIDATED ALL TO 2 SHEETS. UPDATED VIEW ON SHT 1B PICTORIALY TO SHOW REMOVAL OF UNNECESSARY GROUND WIRE BETWEEN POT SHAFT & POT TERMINAL. UPDATED GROUND SYMBOL LOCATION ON SCHEMATIC ACCORDINGLY. REMOVED MLL00020 AND MLM00012. CHANGED QTY OF ITEM 18 FROM 24IN. TO 84IN AND ADDED MLM00180 QTY 2.



**McElroy Manufacturing, Inc.**  
 The leader by design.  
 Tulsa, Oklahoma U.S.A.

DRAWN: TLW	CHECK: RLE	APPRV'D: B	DATE: 11/20/95	DWG No: 1234200	SHT No: 2	REV No: B	PART No: 1234202
#412 LW HEATER BAG ASSEMBLY							CAD No: 1234202

NOTE: THIS DRAWING AND THE INFORMATION CONTAINED THEREIN IS THE CONFIDENTIAL AND PROPRIETARY PROPERTY OF McElroy Manufacturing, Inc. THE DRAWING IS NOT TO BE REPRODUCED IN ANY MANNER, SUBMITTED OUTSIDE PARTIES FOR EXAMINATION, OR USED DIRECTLY OR INDIRECTLY FOR THE PURPOSES OTHER THAN THOSE FOR WHICH IT WAS FURNISHED WITHOUT WRITTEN PERMISSION OF McElroy Manufacturing, Inc.

NOTES:  
 1. CLOSE LOOP THIS HOOK ONLY.

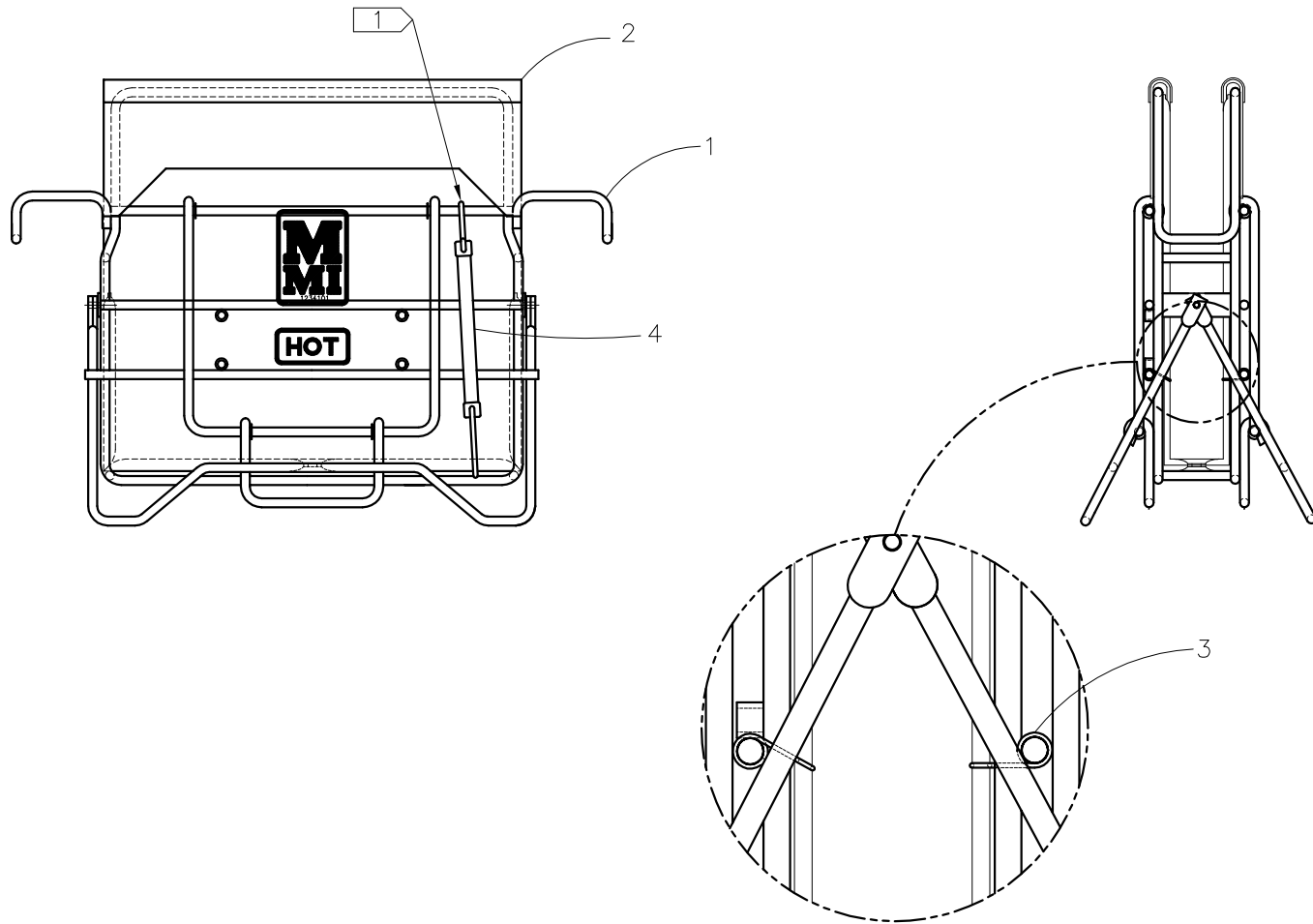

MJG00001	4	1	RUBBER BUNGE CORD
1835208	3	4	LEG RETAINER SPRING
1234101	2	1	INSULATED HEATER BAG
1234305	1	1	HEATER BAG FRAME ASSEMBLY
MMI NUMBER	ITEM	QTY.	SIZE AND DESCRIPTION

UNLESS NOTED OTHERWISE: (3) PLC. DIM'S .XXX = ±0.005" ANGULAR DIM'S = ±1/4" STAMP OR ETCH P/N ON ALL DETAIL PARTS  
 (2) PLC. DIM'S .XX = ±0.010" REMOVE ALL BURRS  
 FRACTIONAL DIM'S = ±1/32" BREAK ALL SHARP EDGES

## DRAWING REVISION HISTORY LISTING

**PART NO:** 1234202

**DESCRIPTION:** #412 LW HEATER BAG ASSEMBLY

<u>APPR.</u>	<u>REV</u>	<u>DATE</u>	<u>BY</u>	<u>DESCRIPTION OF REVISION</u>
B	A	2/11/97	SS	REVISED HEATER BAG FRAME PER WELDMENT 1234305 REV A & 1234101 REV F.
TLW	B	12/6/00	BWW	REVISED DRAWING TO SHOW NEW HEATER BAG FRAME DESIGN AND ADDED NEW PART LEG RETAINER SPRING (1835208) ITEM 3 AND DETAIL FOR ORIENTATION.