



McElroy Manufacturing, Inc.

The leader by design.

Tulsa, Oklahoma U.S.A.

DRAWN: TLW

CHECK: BWP

APPRVD: B

DATE: 11/23/98

SHT No: 1

REV No: G

PART No: 1223201

412/# 618 PIPE STAND ASSEMBLY

NOTE: THIS DRAWING AND THE INFORMATION CONTAINED THEREIN IS THE CONFIDENTIAL AND PROPRIETARY PROPERTY OF McElroy Manufacturing, Inc. THE DRAWING IS NOT TO BE REPRODUCED IN ANY MANNER, SUBMITTED TO OUTSIDE PARTIES FOR EXAMINATION, OR USED DIRECTLY OR INDIRECTLY FOR THE PURPOSES OTHER THAN THOSE FOR WHICH IT WAS FURNISHED WITHOUT WRITTEN PERMISSION OF McElroy Manufacturing, Inc.

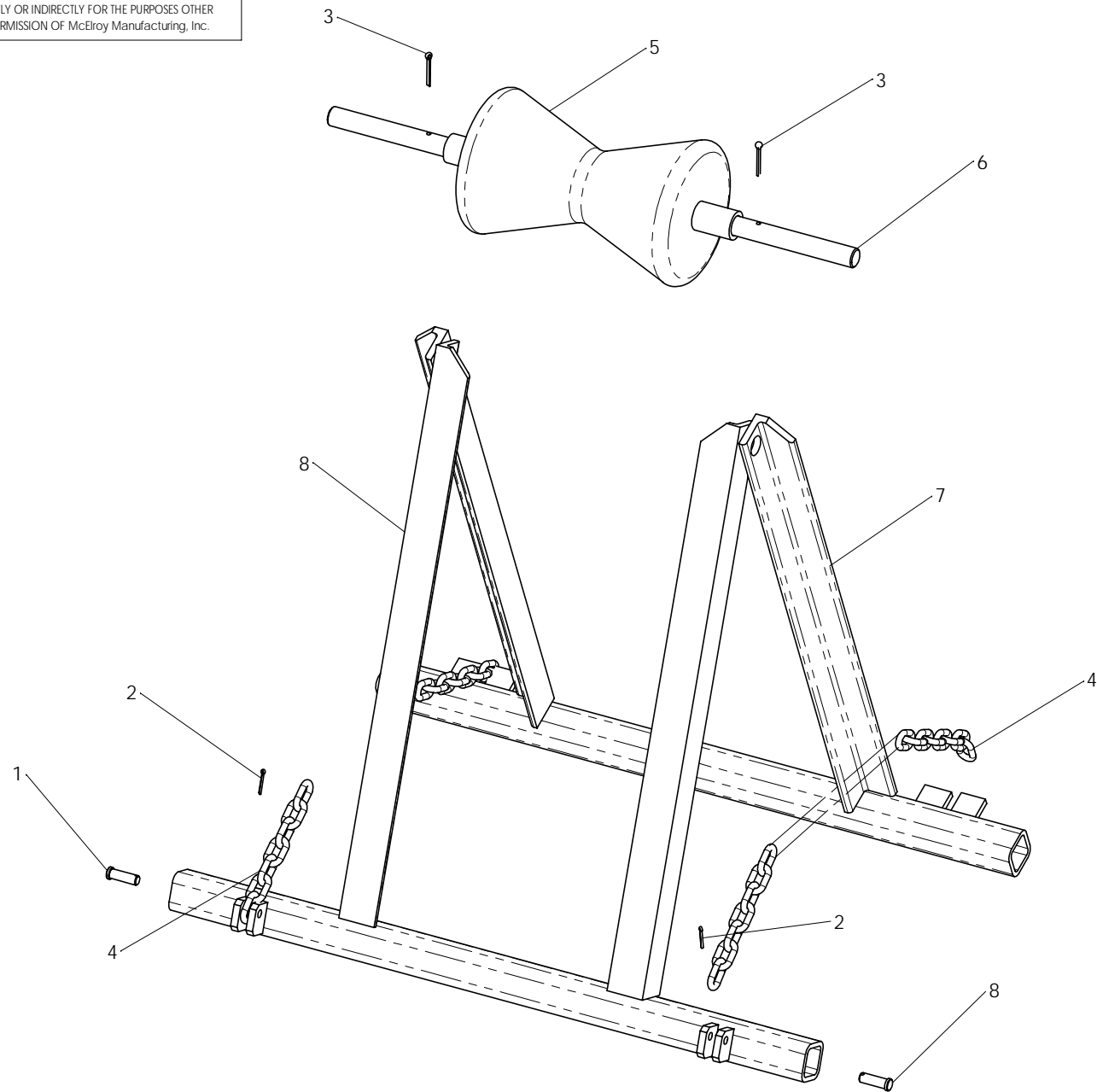

#412/#618 PIPE STAND ASSEMBLYPARTS LIST

ITEM	PART NO.	QTY	DESCRIPTION
	1223201		Assembly
1	MCF00018	2	3/8 DIA. X 1-25/64 LG GRIP CLEVIS PIN
2	MCH00001	2	1/8 DIA. X 1 LG COTTER PIN
3	MCH00003	2	3/16 DIA X 1-1/2 LG COTTER PIN
4	MDG00019	2	5/16 STD CHAIN X 5.2 FT.
5	1223301	1	PIPE STAND ROLLER ASSEMBLY
6	1223401	1	PIPE STAND SHAFT
7	1223202	1	OUTER PIPE STAND WELDMENT
8	1223203	1	INNER PIPE STAND WELDMENT

DRAWING REVISION HISTORY LISTING

PART NO: 1223201
DESCRIPTION: #412/#618 PIPE STAND ASSEMBLY

<u>APPR.</u>	<u>REV</u>	<u>DATE</u>	<u>BY</u>	<u>DESCRIPTION OF REVISION</u>
B	E	05/18/95	TLW	SCANNED AND REDUCED TO 'A' SIZE FORMAT. CREATED TYPED PARTS LIST.
SWB	F	11/23/98	TLW	REVISED WELDMENT WITH (2) CHAINS, THICKEN ANGLE, SQUARE TUBE ON BASE INSTEAD OF PIPE, AND INCREASED WELD SIZE FOR MORE DURABILITY.
SWB	G	08/29/05	BWW	CREATED EXPLODED ISOMETRIC VIEW FOR CLARITY.