



McElroy Manufacturing, Inc.
 The leader by design.
 Tulsa, Oklahoma U.S.A.

DRAWN: BEA	CHECK: MJA	APPRV'D: PJB	DATE: 06/02/04	DWG No: 866500	SHT No: 1A	REV No: B	PART No: 866501
#28 ELECTRICAL BOX/MOTOR SUB-ASSEMBLY 110V, 50Hz, 1Ph							CAD No: 866501

NOTE: THIS DRAWING AND THE INFORMATION CONTAINED THEREIN IS THE CONFIDENTIAL AND PROPRIETARY PROPERTY OF McElroy Manufacturing, Inc. THE DRAWING IS NOT TO BE REPRODUCED IN ANY MANNER, SUBMITTED OUTSIDE PARTIES FOR EXAMINATION, OR USED DIRECTLY OR INDIRECTLY FOR THE PURPOSES OTHER THAN THOSE FOR WHICH IT WAS FURNISHED WITHOUT WRITTEN PERMISSION OF McElroy Manufacturing, Inc.

- NOTES:
1. ITEMS 13, 14 AND 15 ARE NOT SHOWN ON DRAWING.
 2. INSULATE LEADS OF RV1 WITH INSULATION STRIPPED FROM WIRE USED IN ASSEMBLY.
 3. CONNECT MOTOR WIRING FOR CLOCKWISE ROTATION.
 4. ITEMS SHOWN IN PARENTHESIS REFLECT QUANTITIES IN A LOCAL GROUP AND MAY NOT INDICATE TOTAL ASSEMBLY QUANTITIES.

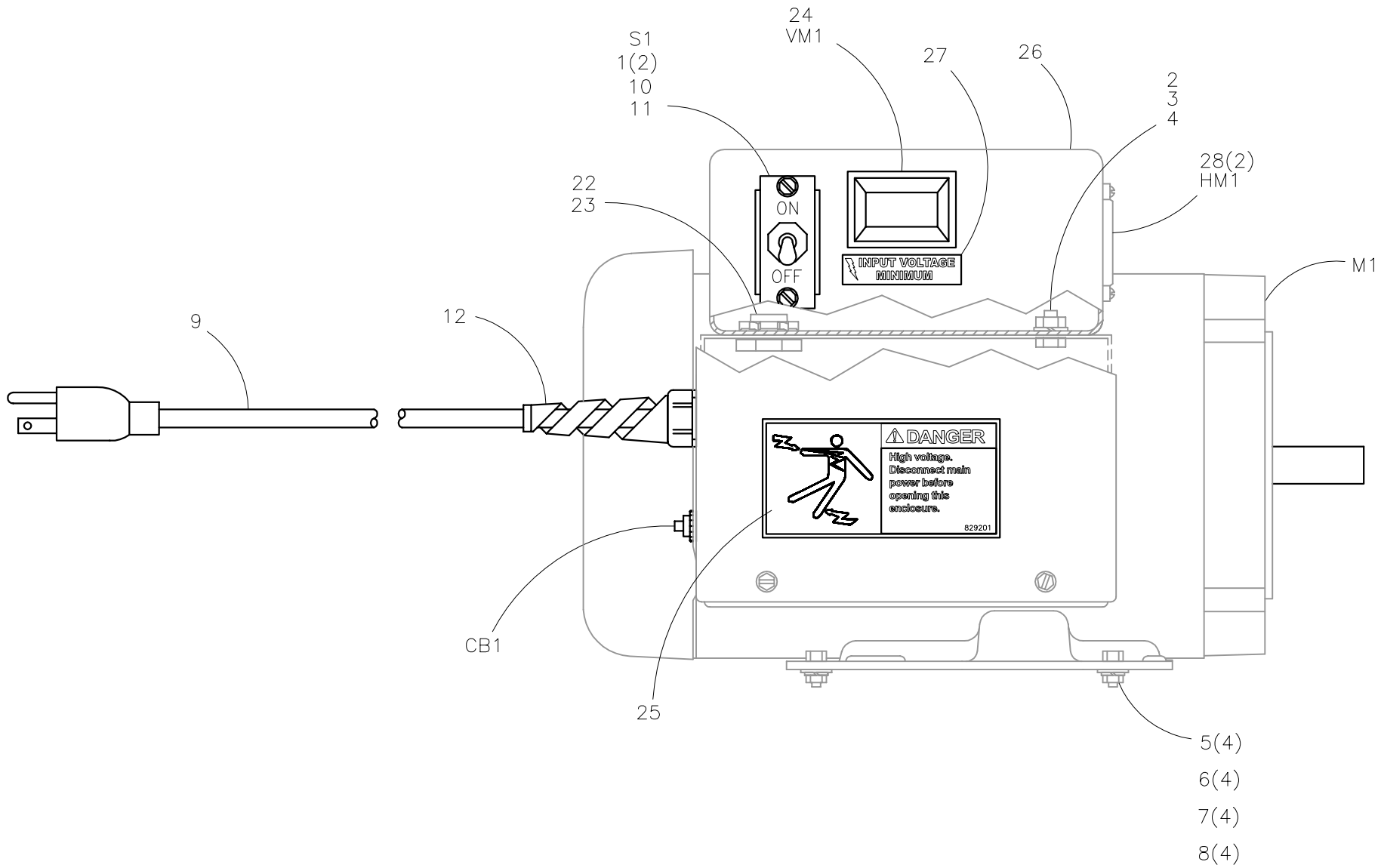



McElroy Manufacturing, Inc.
The leader by design.
Tulsa, Oklahoma U.S.A.

DRAWN: BEA	CHECK: MJA	APPRV'D: PJB	DATE: 06/02/04	DWG No: 866500	SHT No: 1B	REV No: B	PART No: 866501
#28 ELECTRICAL BOX/MOTOR SUB-ASSEMBLY 110V, 50Hz, 1PH							CAD No: 866501

NOTE: THIS DRAWING AND THE INFORMATION CONTAINED THEREIN IS THE CONFIDENTIAL AND PROPRIETARY PROPERTY OF McElroy Manufacturing, Inc. THE DRAWING IS NOT TO BE REPRODUCED IN ANY MANNER, SUBMITTED OUTSIDE PARTIES FOR EXAMINATION, OR USED DIRECTLY OR INDIRECTLY FOR THE PURPOSES OTHER THAN THOSE FOR WHICH IT WAS FURNISHED WITHOUT WRITTEN PERMISSION OF McElroy Manufacturing, Inc.

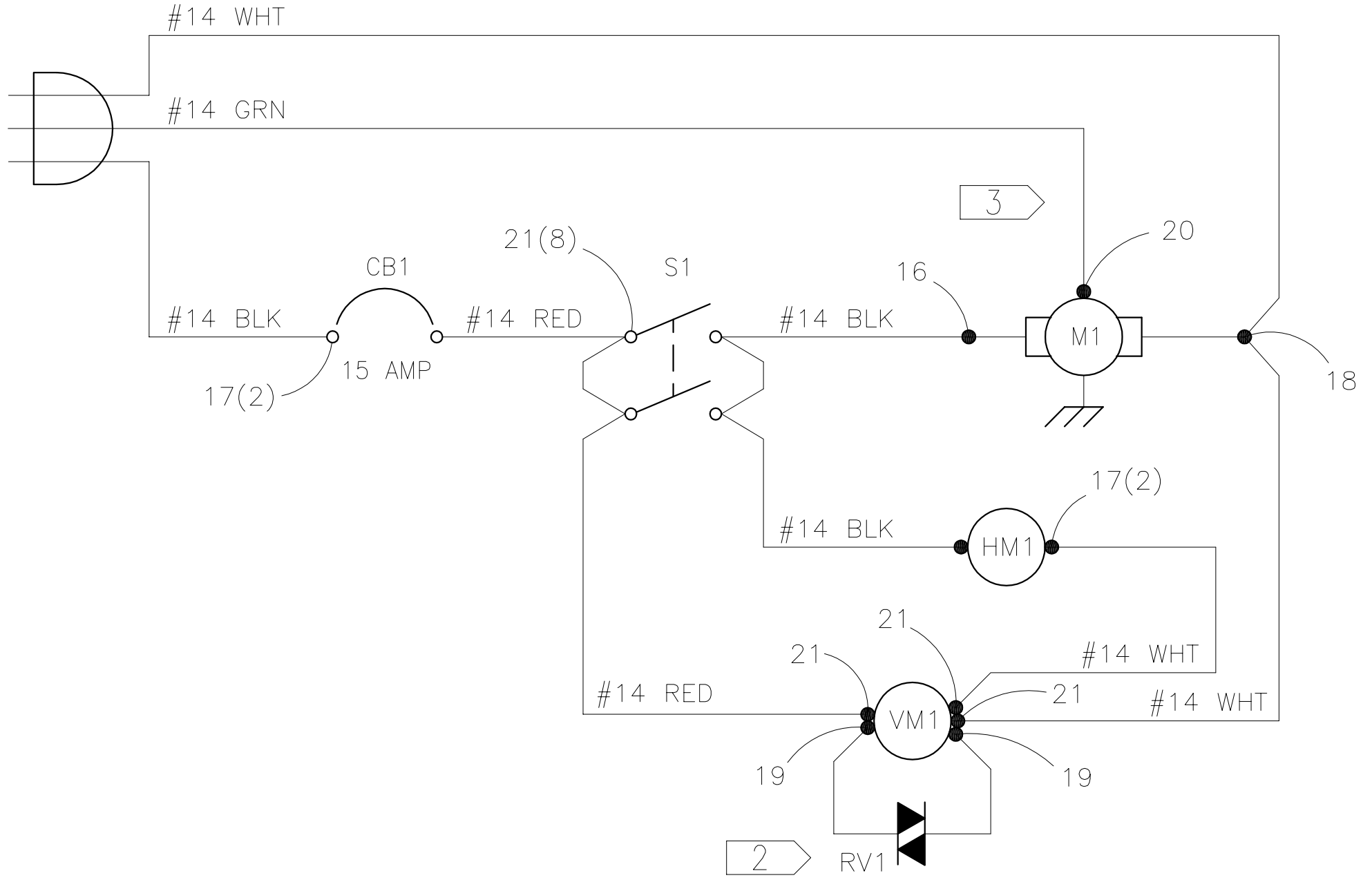

**#28 ELECTRICAL BOX / MOTOR SUB-ASSEMBLY
110V, 50 Hz, 1 Ph**

PARTS LIST

ITEM	PART NO.	QTY	DESCRIPTION
	866501		ASSEMBLY
CB1	MLS00002	1	15 AMP CIRCUIT BREAKER
HM1	MKH00005	1	A/C MULTI-RANGE HOUR METER
M1	837802	1	110-220V, 50HZ MOTOR MODIFICATION
S1	MKE00004	1	SWITCH
VM1	MKH00080	1	PANEL MOUNT DIGITAL VOLTMETER
RV1	MQH00031	1	275V, 23 JOULES MOV
1	MAH00036	2	#6-32 NC X 3/8 LG HWH TC SCREW
2	MAB00002	1	1/4-20 NC X 1/2 LG HHCS
3	MBA00005	1	1/4-20 NC FINISH HEX NUT
4	MBE00005	1	1/4 REGULAR SPLIT LOCK WASHER
5	MAB00033	4	5/16-18 NC X 1 LG HHCS
6	MBA00006	4	5/16-18 NC FINISH HEX NUT
7	MBE00006	4	5/16 REGULAR SPLIT LOCK WASHER
8	MBF00006	4	5/16 TYPE "A" WIDE FLAT WASHER
9	MLE00010	1	#14/3 ELEC CABLE ASSY X 20 FT
10	MLG00001	1	SWITCH GUARD
11	MLH00001	1	SWITCH BOOT
12	MLK00062	1	STRAIN RELIEF CONNECTOR
13	MLL00002	1 FT	#14 MTW / TEW WIRE, BLACK
14	MLL00052	1 FT	#14 MTW / TEW WIRE, WHITE
15	MLL00058	1 FT	#14 MTW / TEW WIRE, RED
16	MLM00016	1	2/16-5/10 WIRE NUT
17	MLM00017	4	1/4 FEMALE DISCONNECT
18	MLM00033	1	TWIST LOCK CONNECTOR
19	MLM00092	2	14-22 X #6 FORK TERMINAL
20	MLM00133	1	14-16 X #10 RING TERMINAL
21	MLM00171	11	14-18 X #6 RING TERMINAL
22	MLN00026	1	1/2 NPT CHASE NIPPLE
23	MLN00100	1	1/2" CONDUIT LOCKNUT
24	MLN00384	1	VOLTMETER BEZEL
25	829201	1	DANGER HIGH VOLTAGE LABEL
26	837902	1	ELECTRICAL BOX MODIFICATION
27	816335	1	85 MIN INPUT VOLTAGE LABEL
28	MAE00004	2	#4-40NC X 3/8 LG. BHSCS SS

DRAWING REVISION HISTORY LISTING

PART NO: 866501

DESCRIPTION: #28 ELECTRICAL BOX/MOTOR SUB-ASSEMBLY 110V, 50Hz, 1Ph

<u>APPR.</u>	<u>REV</u>	<u>DATE</u>	<u>BY</u>	<u>DESCRIPTION OF REVISION</u>
BEA	A	12/01/04	BWW	REVISED TO ADD ITEM 28 MAE00004 QTY 2 FOR HOUR METER ATTACHMENT.
SWB	B	11/28/05	JAB	MOVED NOTES TO FACE OF DRAWING. ADDED NOTE 4 FOR CLARITY.