



McElroy Manufacturing, Inc.
The leader by design.
Tulsa, Oklahoma U.S.A.

DRAWN: BWW	CHECK: TMT	APPRV'D: SWB	DATE: 03/18/02	SHT No: 9	REV No: F	PART No: 848709
------------	------------	--------------	----------------	-----------	-----------	-----------------

#28 DIPS HEATER ASSEMBLY 100-120V, 50/60Hz, 1Ph

NOTE: THIS DRAWING AND THE INFORMATION CONTAINED THEREIN IS THE CONFIDENTIAL AND PROPRIETARY PROPERTY OF McElroy Manufacturing, Inc. THE DRAWING IS NOT TO BE REPRODUCED IN ANY MANNER, SUBMITTED OUTSIDE PARTIES FOR EXAMINATION, OR USED DIRECTLY OR INDIRECTLY FOR THE PURPOSES OTHER THAN THOSE FOR WHICH IT WAS FURNISHED WITHOUT WRITTEN PERMISSION OF McElroy Manufacturing, Inc.

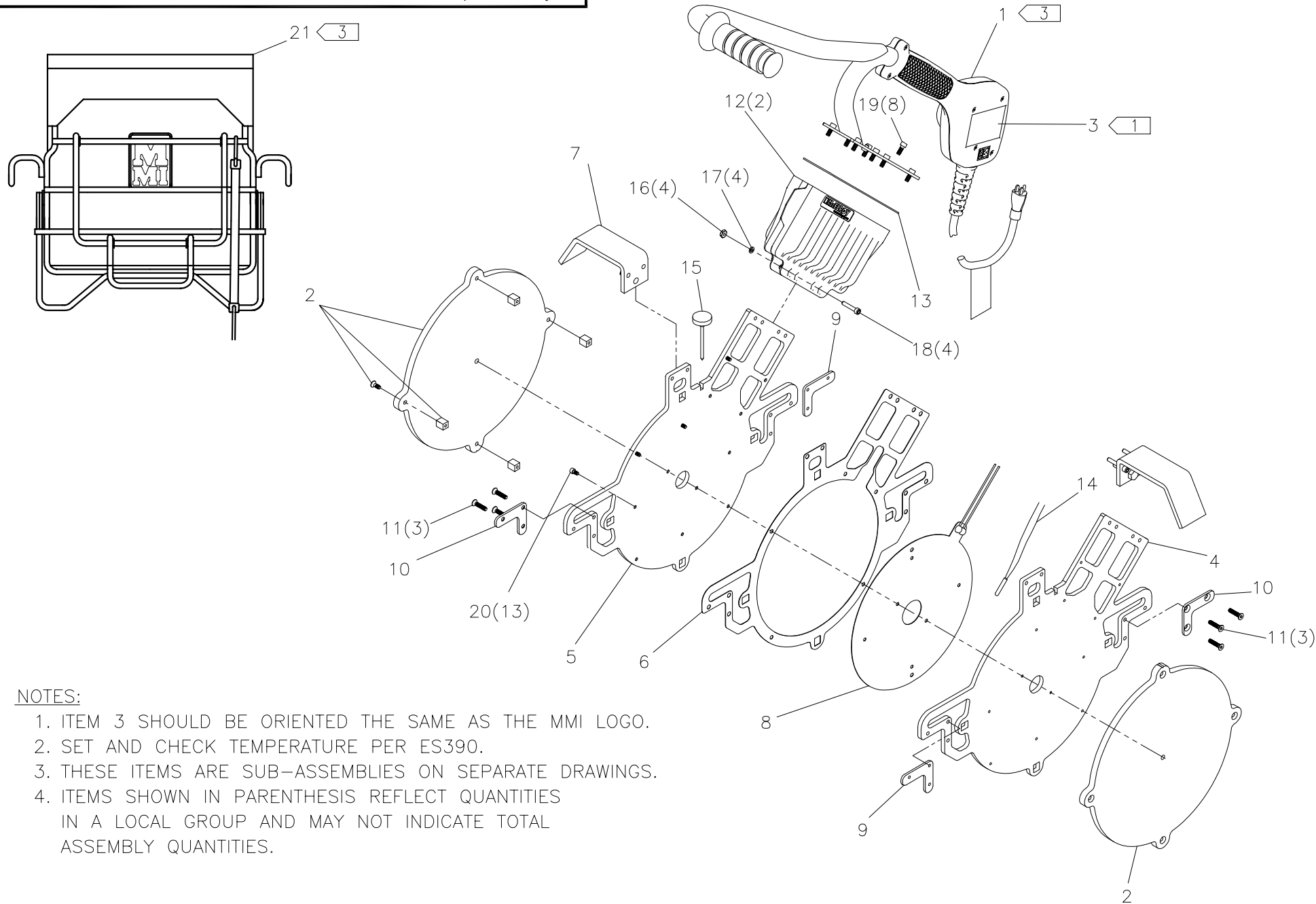

NOTES:

1. ITEM 3 SHOULD BE ORIENTED THE SAME AS THE MMI LOGO.
2. SET AND CHECK TEMPERATURE PER ES390.
3. THESE ITEMS ARE SUB-ASSEMBLIES ON SEPARATE DRAWINGS.
4. ITEMS SHOWN IN PARENTHESIS REFLECT QUANTITIES IN A LOCAL GROUP AND MAY NOT INDICATE TOTAL ASSEMBLY QUANTITIES.

#28 DIPS HEATER ASSEMBLY 100-120V, 50/60Hz, 1PhParts List

ITEM	PART NO.	QTY.	DESCRIPTION
	848709		ASSEMBLY
1	855901	1	8" 100-120V, 50/60Hz, 1Ph HEATER HANDLE/CONTROLLER ASSEMBLY
2	A848706	1	8 DIPS HEATER BUTT PLATE KIT
3	816393	1	MODEL 848709 PART NUMBER LABEL
4	848703	1	RIGHT HEATER BODY
5	848704	1	LEFT HEATER BODY
6	848705	1	HEATER O.D. SPACER
7	A848707	1	HEATER STRIPPER BAR KIT
8	838008	1	120V MICA/FOIL HEATER ELEMENT
9	1852011	2	HEATER GUIDE ROD SUPPORT BRACKET
10	1852012	2	HEATER GUIDE ROD SUPPORT BRACKET
11	MAN00036	6	#10-32NF X 7/8" LG FHSCS SS
12	1863102	2	HEATER TERMINAL ENCLOSURE HALF
13	1808102	1	HEATER GASKET
14	MKI00003	1	100 OHM PLATINUM RTD
15	MJK00002	1	THERMOMETER
16	MBA00004	4	#10-24NC FINISHED HEX NUT
17	MBE00004	4	#10 REGULAR SPLIT LOCK WASHER
18	MAN00008	4	#10-24NC X 1" LG SHCS SS
19	MAH00046	8	#10-24NC X 1/2" LG SHCS SS
20	MAN00023	13	#8-32NC X 5/16" LG SHCS SS
21	821802	1	HEATER BAG ASSEMBLY

DRAWING REVISION HISTORY LISTING

PART NO: 848709
DESCRIPTION: #28 DIPS HEATER ASSEMBLY 100-120V, 50/60Hz, 1Ph

<u>APPR.</u>	<u>REV</u>	<u>DATE</u>	<u>BY</u>	<u>DESCRIPTION OF REVISION</u>
SWB	A	04/28/03	BWW	ADDED ITEM 47 MLN00219 WITH A QTY OF 4IN & ADDED NOTE 7 FOR TAPING WIRES. ADDED LENGTH TOLERANCE TO LEAD CUT LENGTH DETAIL. UPDATED PICTORIALY ITEM 29 TO NEW DESIGN WHICH WAS IMPLEMENTED MARCH 2003.
SWB	B	8/15/03	RLE	REVISED STRIP LENGTH ON RTD ONLY FROM 3/16 TO 3/8 TO MAKE COMPATIBLE WITH CONNECTOR USED ON REV. 'B' HEATER CONTROL PCB ASSEMBLY (T5030001) & UPDATED PICTURE OF HEATER CONTROL PCB ASSEMBLY.
SWB	C	10/27/03	BWW	CORRECTED PICTORIALY THE VIEW OF THE PCB BOARD ON SHT 9C AND 9D TO SHOW CURRENT DESIGN.
SWB	D	03/17/04	ALK	REVISED DRAWING TO REMOVE ITEMS 2 MAC00095, 7 MBA00007, 9 MBE00007, 17 1207302, 25 1810902, & 26 1852008. ADDED ITEM 48 1863102 QTY 2. CHANGES MADE TO IMPLEMENT USE OF DIE CAST TERMINAL ENCLOSURE.
WBD	E	3/22/04	ALK	REMOVED ITEMS #13 1852017 & #14 1852018, REVISED TO REMOVE UNNECESSARY SHIMS.
swb	F	08/02/05	BWW	REVISED PICTORIALY TO SHOW EXPLODED ISOMETRIC VIEW ON SHT 9 & CONSOLIDATED ALL TO 1 SHEET. ADDED 855901 HANDLE ASSEMBLY. REMOVED THE FOLLOWING ITEMS: 3 MAH00030, 10 MJJ00009, 15 853601, 16 MDL00243, 29 838007, 30 410906, 33 816382, 35 T5030103, 36 T5030001, 37 T5030002, 38 MBA00067, 39 MJJ00023, 40 MLM00010, 41 MLM00024, 42 MAL00010, 43 MAL00011, 44 MDL00018, 46 MLL00025, 47 MBG00072, 48 MLN00219 WHICH WERE CONSOLIDATED IN 855901.



McElroy Manufacturing, Inc.
 The leader by design.
 Tulsa, Oklahoma U.S.A.

DRAWN: BWW	CHECK: TMT	APPRV'D: SWB	DATE: 06/14/02	DWG No: 855900	SHT No: 1A	REV No: D	PART No: 855901
8" 100-120V,50/60Hz,1Ph HEATER HANDLE/CONTROLLER ASSEMBLY							CAD No: 855901

NOTE: THIS DRAWING AND THE INFORMATION CONTAINED THEREIN IS THE CONFIDENTIAL AND PROPRIETARY PROPERTY OF McElroy Manufacturing, Inc. THE DRAWING IS NOT TO BE REPRODUCED IN ANY MANNER, SUBMITTED OUTSIDE PARTIES FOR EXAMINATION, OR USED DIRECTLY OR INDIRECTLY FOR THE PURPOSES OTHER THAN THOSE FOR WHICH IT WAS FURNISHED WITHOUT WRITTEN PERMISSION OF McElroy Manufacturing, Inc.

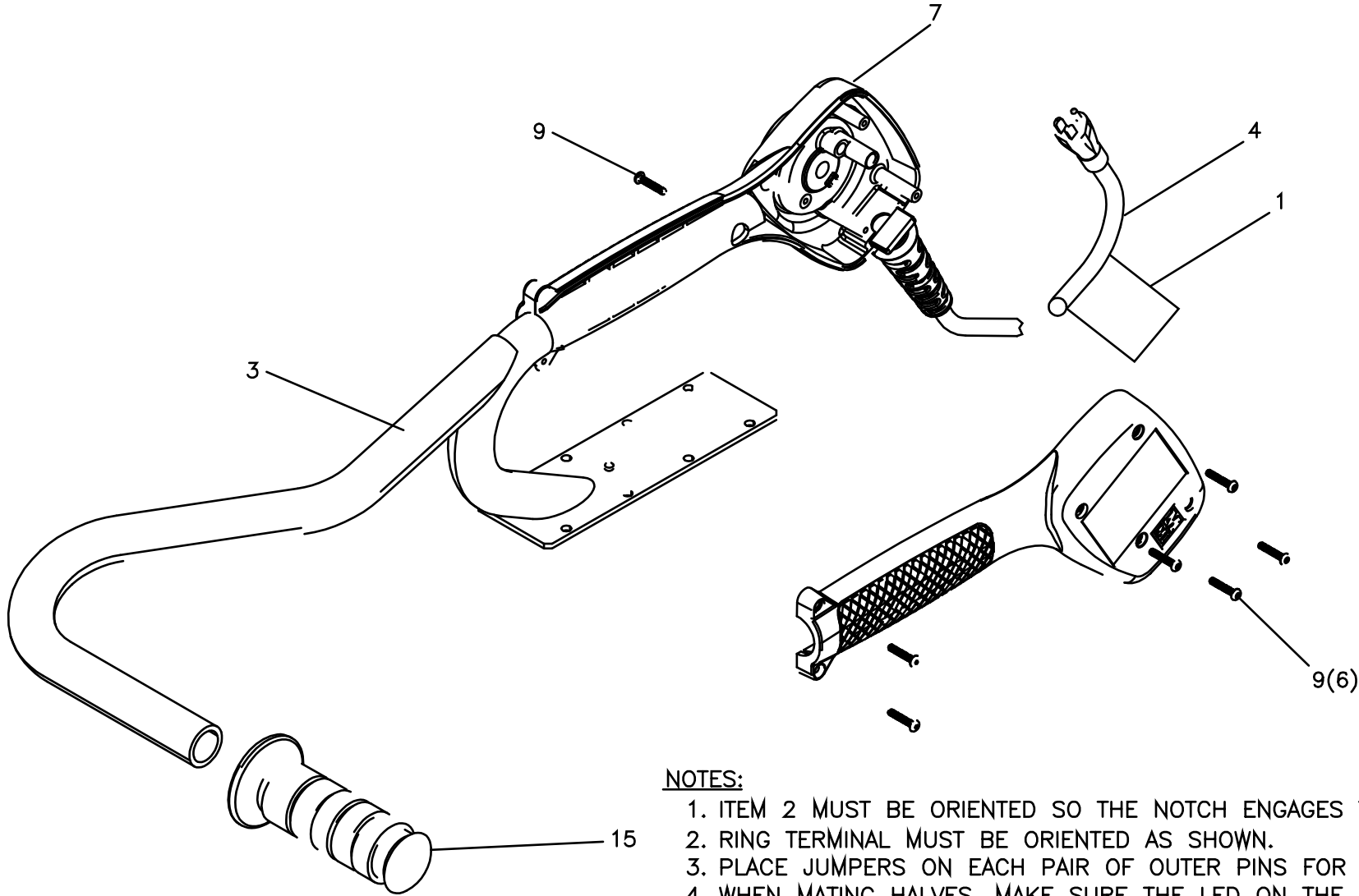

NOTES:

1. ITEM 2 MUST BE ORIENTED SO THE NOTCH ENGAGES THE KEY ON ITEM 7.
2. RING TERMINAL MUST BE ORIENTED AS SHOWN.
3. PLACE JUMPERS ON EACH PAIR OF OUTER PINS FOR 100-120V OPERATION.
4. WHEN MATING HALVES, MAKE SURE THE LED ON THE PC BOARD FITS INTO LONG SOCKET ON COVER.
5. TAPE WIRES IN AREA SHOWN TO PREVENT DAMAGE.
6. PAINT THIS WIRE WITH HIGH TEMP GREEN PAINT TO MARK AS GROUND WIRE.
7. ITEMS SHOWN IN PARENTHESIS REFLECT QUANTITIES IN A LOCAL GROUP AND DO NOT INDICATE TOTAL ASSEMBLY QUANTITIES.



McElroy Manufacturing, Inc.
The leader by design.
Tulsa, Oklahoma U.S.A.

DRAWN: BWW	CHECK: TMT	APPRV'D: SWB	DATE: 06/14/02	DWG No: 855900	SHT No: 1B	REV No: D	PART No: 855901
8" 100-120V,50/60Hz,1Ph HEATER HANDLE/CONTROLLER ASSEMBLY							CAD No: 855901

NOTE: THIS DRAWING AND THE INFORMATION CONTAINED THEREIN IS THE CONFIDENTIAL AND PROPRIETARY PROPERTY OF McElroy Manufacturing, Inc. THE DRAWING IS NOT TO BE REPRODUCED IN ANY MANNER, SUBMITTED OUTSIDE PARTIES FOR EXAMINATION, OR USED DIRECTLY OR INDIRECTLY FOR THE PURPOSES OTHER THAN THOSE FOR WHICH IT WAS FURNISHED WITHOUT WRITTEN PERMISSION OF McElroy Manufacturing, Inc.

120 VAC PLUG

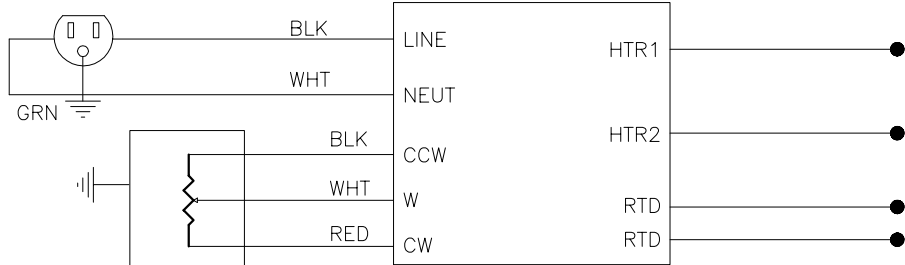

TEMP ADJUST

SECTION A-A

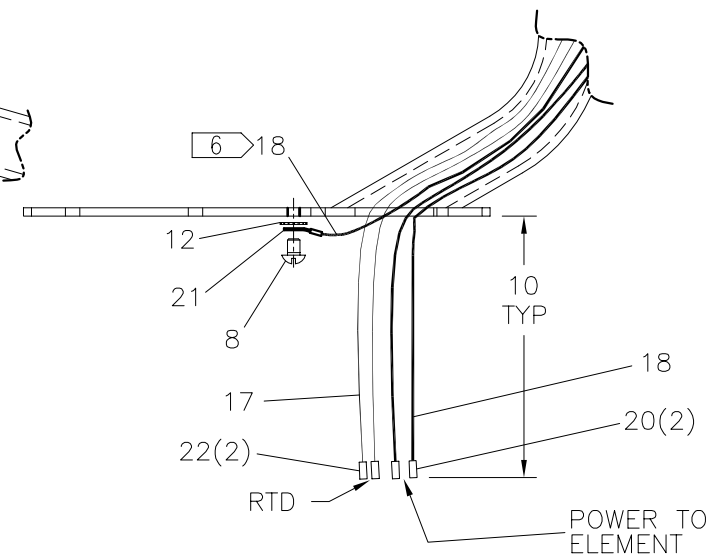
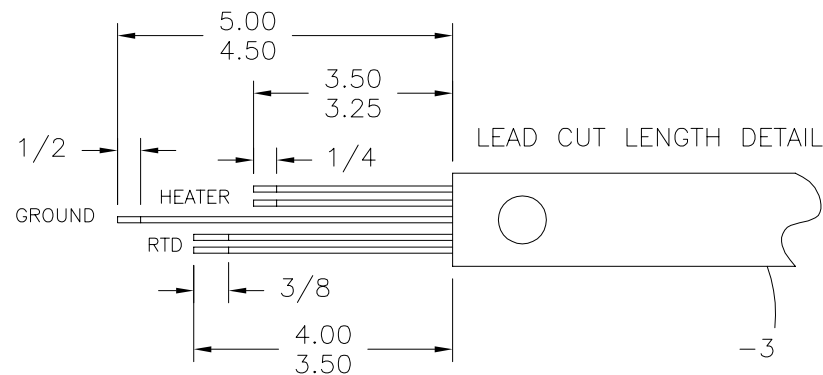
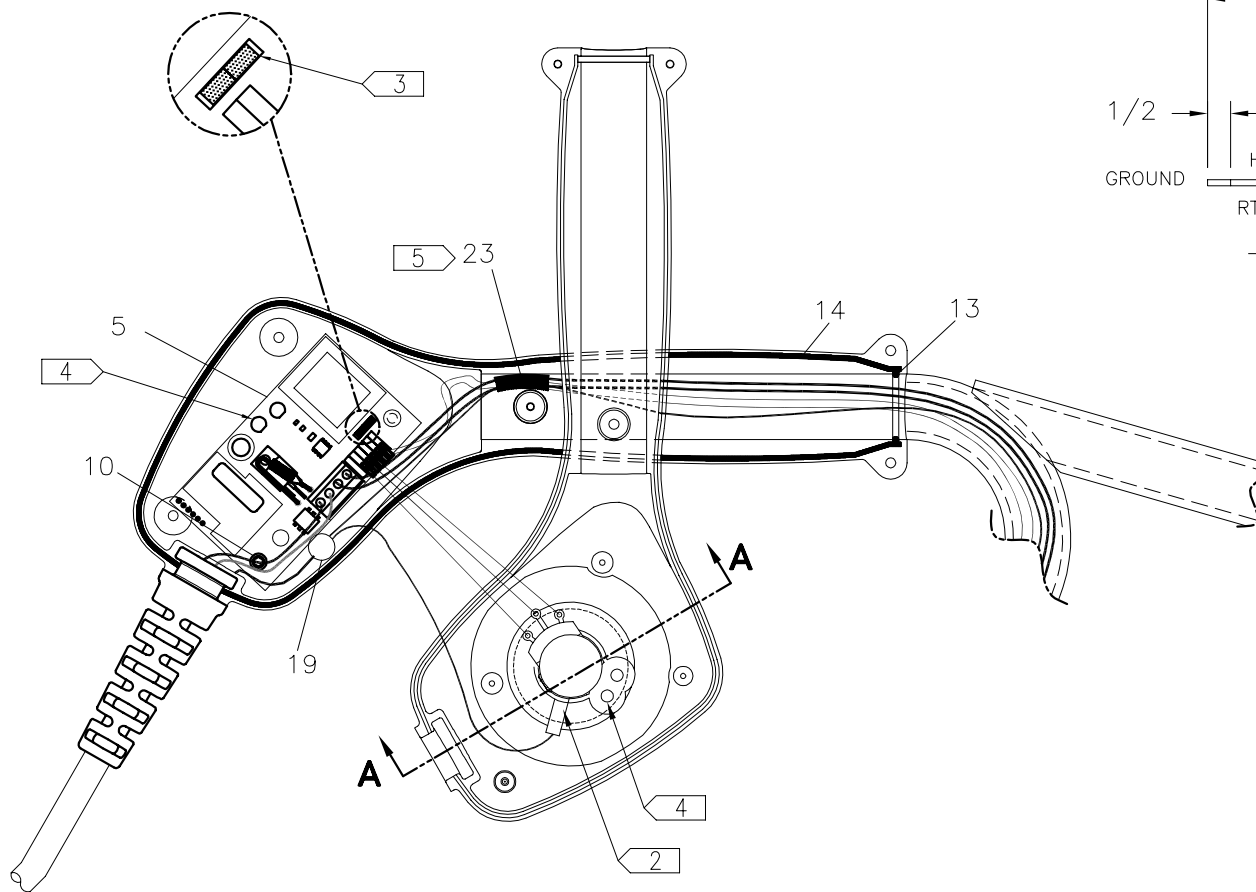
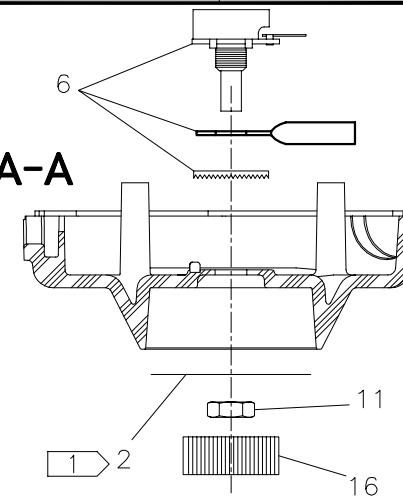

**8" 100-120V, 50/60Hz, 1Ph HEATER
HANDLE/CONTROLLER ASSEMBLY**

Parts List

ITEM	PART NO.	QTY.	DESCRIPTION
	855901		ASSEMBLY
1	410906	1	DANGER NOT EXPLOSION PROOF TAG LABEL
2	816382	1	TEMPERATURE SCALE LABEL
3	838007	1	HEATER HANDLE WELDMENT
4	853601	1	15AMP/125V POWER CORD
5	T5030001	1	HEATER CONTROL PCB ASSEMBLY
6	T5030002	1	POTENTIOMETER ASSEMBLY
7	T5030103	1	HEATER HANDLE/ENCLOSURE
8	MAH00030	1	#10-24NC X 1/4 LG RHSMS
9	MAL00010	7	#6-19 x 3/4LG TORX T15 PAN HEAD SCREW
10	MAL00011	1	#6-19 x 1/4LG TORX T15 PAN HEAD SCREW
11	MBA00067	1	HEX SEAL NUT
12	MBG00072	1	#10 INTERNAL TOOTHED LOCK WASHER
13	MDL00018	1	O-RING
14	MDL00243	26IN	.070 DIA. BUNA-N O-RING STOCK
15	MJJ00009	1	BLACK HAND GRIP
16	MJJ00023	1	CONTROL KNOB
17	MLL00004	60IN	#18 TYPE TGGT ELECTRICAL WIRE
18	MLL00025	84IN	#12 TYPE TGGT ELECTRICAL WIRE
19	MLM00010	1	CONNECTOR
20	MLM00180	2	10-12 HI-TEMP BUTT SPLICE
21	MLM00024	1	RING TERMINAL
22	MLM00040	2	CONNECTOR
23	MLN00219	4IN	FIBERGLASS TAPE

DRAWING REVISION HISTORY LISTING

PART NO: 855901
DESCRIPTION: 8" 100-120V, 50/60Hz, 1Ph HEATER HANDLE/CONTROLLER ASSEMBLY

<u>APPR.</u>	<u>REV</u>	<u>DATE</u>	<u>BY</u>	<u>DESCRIPTION OF REVISION</u>
SWB	A	04/28/03	BWW	ADDED ITEM 25 MLN00219 WITH A QTY OF 4IN & ADDED NOTE 6 FOR TAPING WIRES. ADDED LENGTH TOLERANCE TO LEAD CUT LENGTH DETAIL. UPDATED PICTORIALY ITEM 4 TO NEW DESIGN WHICH WAS IMPLEMENTED MARCH 2003.
SWB	B	8/18/03	RLE	REVISED STRIP LENGTH ON RTD ONLY FROM 3/16 TO 3/8 TO MAKE COMPATIBLE WITH CONNECTOR USED ON REV. 'B' HEATER CONTROL PCB ASSEMBLY (T5030001) & UPDATED PICTURE OF HEATER CONTROL PCB ASSEMBLY.
SWB	C	10/27/03	BWW	CORRECTED PICTORIALY THE VIEW OF THE PCB BOARD ON SHT 1C AND 1D TO SHOW CURRENT DESIGN.
SWB	D	08/02/05	BWW	REVISED PICTORIALY TO SHOW EXPLODED ISOMETRIC VIEW ON SHT 1A & CONSOLIDATED ALL TO 2 SHEETS. UPDATED VIEW ON SHT 1B PICTORIALY TO SHOW REMOVAL OF UNNECESSARY GROUND WIRE BETWEEN POT SHAFT & POT TERMINAL. UPDATED GROUND SYMBOL LOCATION ON SCHEMATIC ACCORDINGLY. REMOVED 816393 TO MAKE THIS DRAWING GENERIC FOR MANY MODELS. REMOVED MLL00020 AND MLM00012, ADDED MLM00180 QTY 2 AND CHANGED LENGTH OF ITEM 18 TO 84".



McElroy Manufacturing, Inc.
The leader by design.
Tulsa, Oklahoma U.S.A.

DRAWN: TLW	CHECK: JRP	APPRV'D: B	DATE: 8/3/96	DWG No: 821800	SHT No: 2	REV No: E	PART No: 821802
#28 LW HEATER BAG ASSEMBLY							CAD No: 821802

NOTE: THIS DRAWING AND THE INFORMATION CONTAINED THEREIN IS THE CONFIDENTIAL AND PROPRIETARY PROPERTY OF McElroy Manufacturing, Inc. THE DRAWING IS NOT TO BE REPRODUCED IN ANY MANNER, SUBMITTED OUTSIDE PARTIES FOR EXAMINATION, OR USED DIRECTLY OR INDIRECTLY FOR THE PURPOSES OTHER THAN THOSE FOR WHICH IT WAS FURNISHED WITHOUT WRITTEN PERMISSION OF McElroy Manufacturing, Inc.

NOTES:

1. CLOSE LOOP THIS HOOK ONLY.

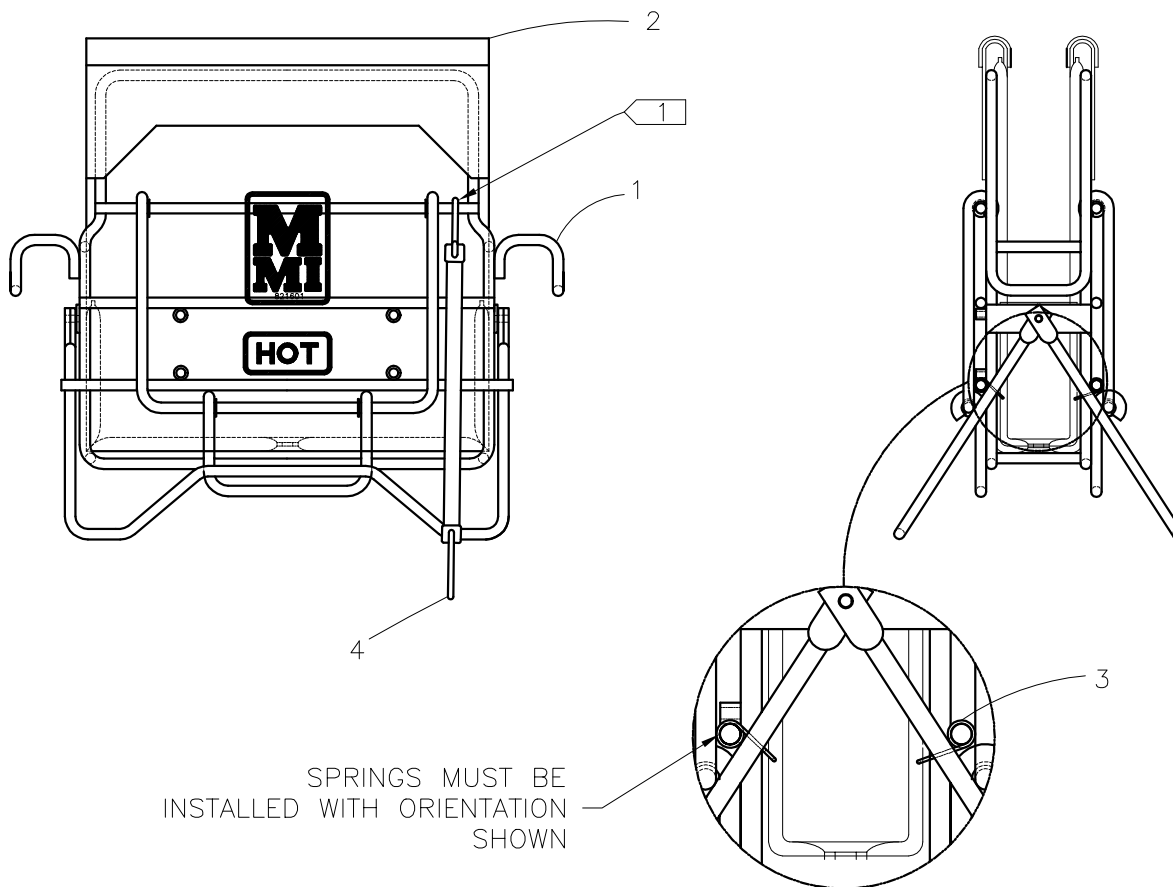

SPRINGS MUST BE INSTALLED WITH ORIENTATION SHOWN

MJG00001	4	1	RUBBER BUNGE CORD
1835208	3	4	LEG RETAINER SPRING
821601	2	1	INSULATED HEATER BAG
821905	1	1	HEATER BAG FRAME ASSEMBLY

UNLESS NOTED OTHERWISE: (3) PLC. DIM'S .XXX = ±0.005" ANGULAR DIM'S = ±1/4" STAMP OR ETCH P/N ON ALL DETAIL PARTS
(2) PLC. DIM'S .XX = ±0.010" REMOVE ALL BURRS
FRACTIONAL DIM'S = ±1/32" BREAK ALL SHARP EDGES

MMI NUMBER	ITEM	QTY.	SIZE AND DESCRIPTION
------------	------	------	----------------------

DRAWING REVISION HISTORY LISTING

PART NO: 821802

DESCRIPTION: #28 LW HEATER BAG ASSEMBLY

<u>APPR.</u>	<u>REV</u>	<u>DATE</u>	<u>BY</u>	<u>DESCRIPTION OF REVISION</u>
B	A	8/3/95	TLW	Reduced to 'A' size format. Created typed parts list.
SWB	B	10/24/96	SS	Modify drawing to reflect yellow straps on bag, change item #2 MJQ00051 to 821601
B	C	2/11/97	SS	REVISED BAG FRAME PER WELDMENT 821905 REV. C. ADDED TIE STRAP PER 821601 REV F. RE-NUMBERED DRAWING AND BOM TO ORGANIZE.
TLW	D	02/13/98	JPS	REVISED DRAWING TO NEW VELCRO STRAP (822001). & DELETED HARDWARE ITEMS 3, 4, & 5 FOR ATTACHING OLD STRAP.
TLW	E	12/7/00	BWW	REVISED DRAWING TO SHOW NEW HEATER BAG FRAME DESIGN AND ADDED NEW PART LEG RETAINER SPRING (1835208) ITEM 3 AND DETAIL FOR ORIENTATION. REMOVED ITEM #7 (822001) CARRYING STRAP.