



McElroy Manufacturing, Inc.
 The leader by design.
 Tulsa, Oklahoma U.S.A.

DRAWN: TLW	CHECK: SWB	APPRV'D: B	DATE: 01/05/96	DWG No: 846900	SHT No: 1A	REV No: H	PART No: 846901
#28 ELECTRICAL BOX/MOTOR SUB-ASSEMBLY 120V, 60Hz, 1Ph							CAD No: 846901

NOTE: THIS DRAWING AND THE INFORMATION CONTAINED THEREIN IS THE CONFIDENTIAL AND PROPRIETARY PROPERTY OF McElroy Manufacturing, Inc. THE DRAWING IS NOT TO BE REPRODUCED IN ANY MANNER, SUBMITTED OUTSIDE PARTIES FOR EXAMINATION, OR USED DIRECTLY OR INDIRECTLY FOR THE PURPOSES OTHER THAN THOSE FOR WHICH IT WAS FURNISHED WITHOUT WRITTEN PERMISSION OF McElroy Manufacturing, Inc.

- NOTES:**
1. INSULATE LEADS OF RV1 WITH INSULATION STRIPPED FROM WIRE USED IN ASSEMBLY.
 2. ITEMS 21,22 AND 23 ARE NOT SHOWN ON DRAWING.

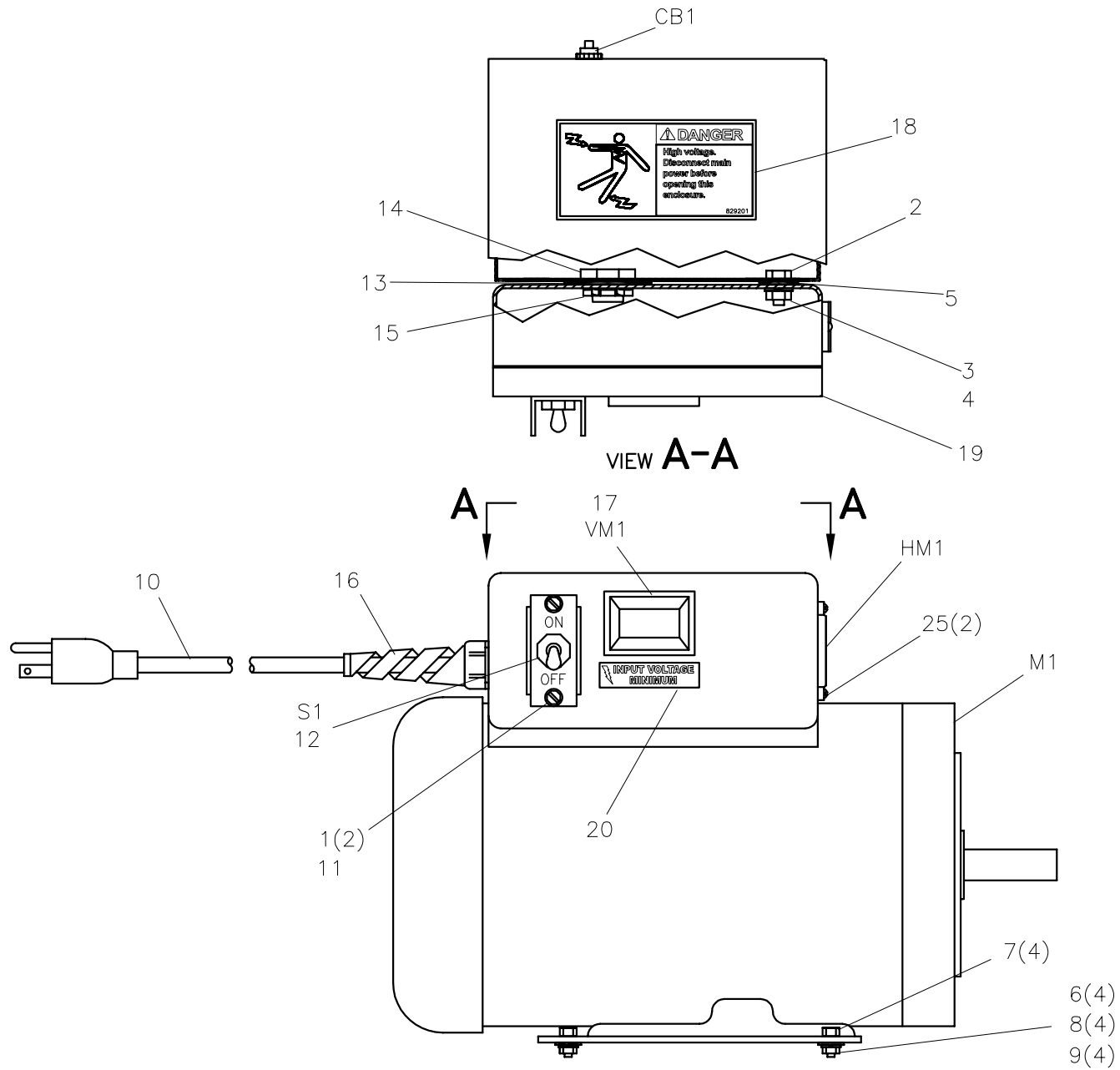



McElroy Manufacturing, Inc.
 The leader by design.
 Tulsa, Oklahoma U.S.A.

DRAWN: TLW	CHECK: SWB	APPRV'D: B	DATE: 02/20/96	DWG No: 846900	SHT No: 1B	REV No: H	PART No: 846901
#28 ELECTRICAL BOX/MOTOR SUB-ASSEMBLY 120V, 60Hz, 1PH							CAD No: 846901

NOTE: THIS DRAWING AND THE INFORMATION CONTAINED THEREIN IS THE CONFIDENTIAL AND PROPRIETARY PROPERTY OF McElroy Manufacturing, Inc. THE DRAWING IS NOT TO BE REPRODUCED IN ANY MANNER, SUBMITTED OUTSIDE PARTIES FOR EXAMINATION, OR USED DIRECTLY OR INDIRECTLY FOR THE PURPOSES OTHER THAN THOSE FOR WHICH IT WAS FURNISHED WITHOUT WRITTEN PERMISSION OF McElroy Manufacturing, Inc.

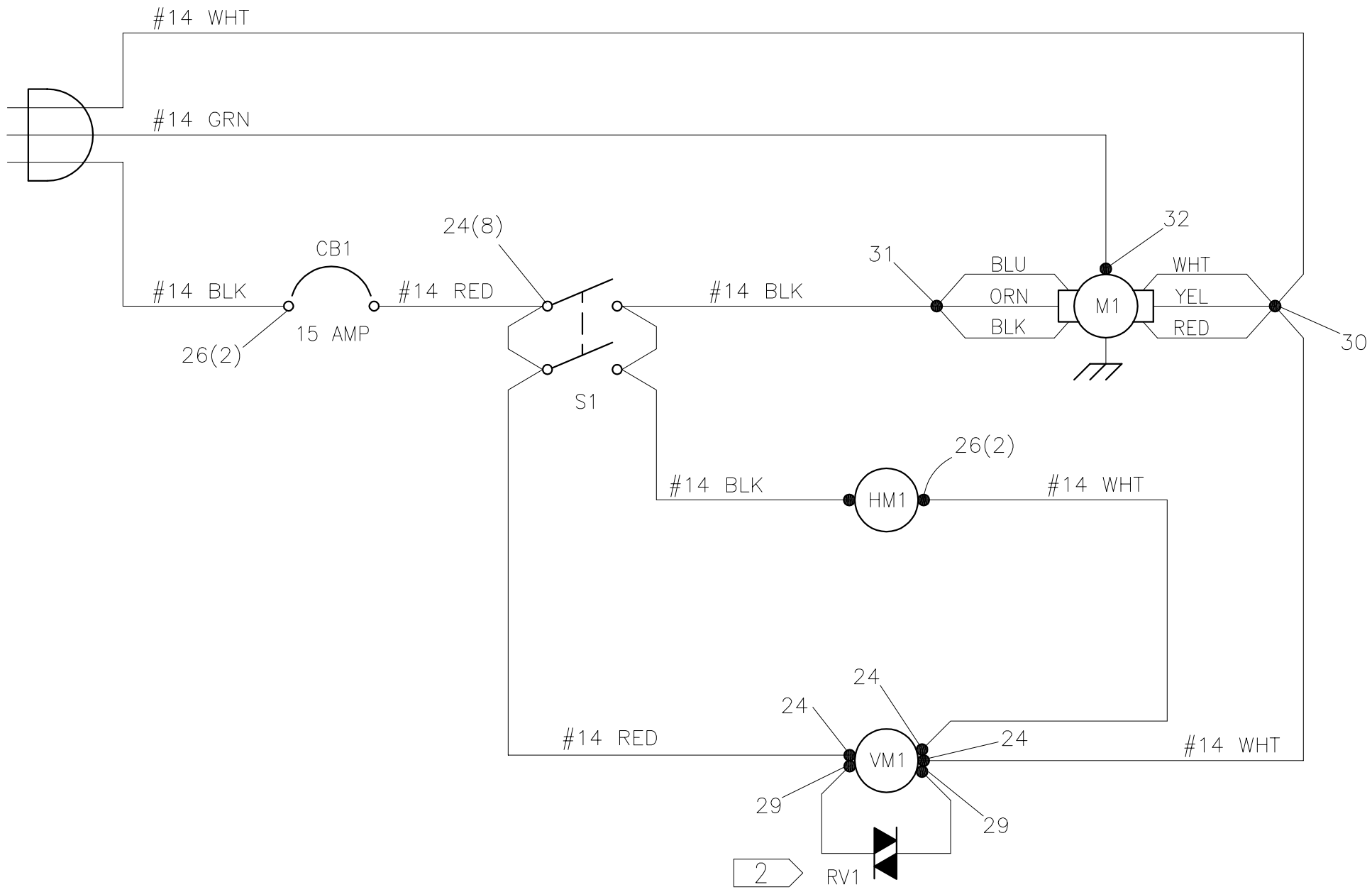

**#28 ELECTRICAL BOX / MOTOR SUB-ASSEMBLY
120V, 60 Hz, 1 Ph**

PARTS LIST

ITEM	PART NO.	QTY	DESCRIPTION
	846901		ASSEMBLY
CB1	MLS00002	1	15 AMP CIRCUIT BREAKER
HM1	MKH00005	1	A/C MULTI-RANGE HOUR METER
M1	837804	1	120, 60 MOTOR MODIFICATION
S1	MKE00004	1	SWITCH
VM1	MKH00080	1	PANEL MOUNT DIGITAL VOLTMETER
RV1	MQH00031	1	275V, 23 JOULES MOV
1	MAH00036	2	#6-32 NC X 3/8 LG HWH TC SCREW
2	MAB00002	1	1/4-20 NC X 1/2 LG HHCS
3	MBA00005	1	1/4-20 NC FINISH HEX NUT
4	MBE00005	1	1/4 REG SPLIT LOCK WASHER
5	MBF00005	1	1/4 TYPE "A" WIDE FLAT WASHER
6	MAB00033	4	5/16-18 NC X 1 LG HHCS
7	MBA00006	4	5/16-18 NC FINISH HEX NUT
8	MBE00006	4	5/16 REG SPLIT LOCK WASHER
9	MBF00006	4	5/16 TYPE "A" WIDE FLAT WASHER
10	MLE00010	1	#14/3 ELEC CABLE ASSY X 20 FT
11	MLG00001	1	SWITCH GUARD
12	MLH00001	1	SWITCH BOOT
13	MLJ00045	1	3/4 X 1/2 REDUCER WASHER
14	MLJ00068	1	1/2 X 1 LG CONDUIT NIPPLE
15	MLN00100	1	1/2" CONDUIT LOCKNUT
16	MLK00062	1	STRAIN RELIEF CONNECTOR
17	MLN00384	1	VOLTMETER BEZEL
18	829201	1	DANGER HIGH VOLTAGE LABEL
19	837903	1	ELECTRICAL BOX MODIFICATION
20	816324	1	103 MIN INPUT VOLTAGE LABEL
21	MLL00002	1 FT	#14 MTW / TEW WIRE, BLACK
22	MLL00052	1 FT	#14 MTW / TEW WIRE, WHITE
23	MLL00058	1 FT	#14 MTW / TEW WIRE, RED
24	MLM00171	11	14-18 X #6 RING TERMINAL
25	MAE00004	2	#4-40NC X 3/8LG BHSCS SS
26	MLM00017	4	1/4 FEMALE DISCONNECT
27			
28			
29	MLM00092	2	14-22 X #6 FORK TERMINAL
30	MLM00033	1	TWIST LOCK CONNECTOR
31	MLM00016	1	2/16-5/10 WIRE NUT
32	MLM00133	1	14-16 X #10 RING TERMINAL

DRAWING REVISION HISTORY LISTING

PART NO: 846901
DESCRIPTION: #28 ELECTRICAL BOX/MOTOR SUB-ASSEMBLY 120V, 60Hz, 1Ph

<u>APPR.</u>	<u>REV</u>	<u>DATE</u>	<u>BY</u>	<u>DESCRIPTION OF REVISION</u>
SWB	A	02/20/96	TLW	ADDED RV1, (MQH00031) QTY 1 METAL OXIDE VARISTOR.
SWB	----	08/21/96	TLW	ADDED NOTE 1. REMOVE THERMAL MOTOR PROTECTOR. SEAL HOLES AND RUBBER BOOT. CONNECT WIRING AS SHOWN FOR CLOCKWISE ROTATION. REMOVE THERMAL WARNING DECAL.
SWB	B	01/08/97	SWB	ADDED NOTE 2 TO SHT 1. JOINED 8469S01 AND 8469S02 CAD FILES TOGETHER AND RENAMED TO 846901.DWG. INCREMENTED SHT 2 FROM NO REV TO REV B IN ORDER TO SYNC WITH SHT 1.
TLW	C	07/21/00	PB	REVISED ITEM HM1 HOUR METER TO A MULTI-RANGE METER. CORRECTED QTY OF ITEM 18, MLM00001, RING TERMINAL FROM 5 TO 4 AND ADDED WP20 LOCATION. ADDED WP9 AND 10 TO ITEM 22 AND CHANGED QTY FROM 2 TO 4. SEE PCR 99037.
RAD	D	01/22/02	BEA	UPDATED DRAWINGS FROM ORCAD TO CURRENT METHODS. RENAMED DRAWINGS 846900 SHEETS 1A AND 1B INSTEAD OF SHEETS 1 AND 2 TO COMBINE BOM. DELETED MLM00001, MLM00016, MLM00119 AND MLJ00068. ADDED MLM00010, MLM00092, MLM00120, MLM00171 AND MLN00026. CHANGED QTY OF MLL00002 FROM 25 FT TO 1 FT. CHANGED QTY OF MLM00034 FROM 1 TO 2. Changed QTY OF MLL00052 FROM 2 FT TO 1 FT.
SWB	E	08/19/02	LBK	CHANGED ITEM 14 FROM MLN00026 TO MLJ00068 TO MATCH AS BUILT.
PJB	F	02/14/03	BEA	DELETED ITEM 27, MLM00034, YELLOW TWISTLOCK. DELETED ITEM 25, MLM00010, WIRE NUT. ADDED ITEM 30, MLM00033, GRAY TWISTLOCK. ADDED ITEM 31, MLM00016, WIRE NUT. ADDED ITEM 32, MLM00133, RING TERMINAL. CHANGED QTY OF ITEM 24 FROM 8 TO 11. CHANGES MADE TO MATCH AS BUILT.
PJB	-	05/1/03	BEA	DELETED ITEM 28, MLM00120 FROM BOM. PART WAS REMOVED FROM DRAWING IN REV F.
JRP	G	9/15/04	BEA	ADDED ITEM 25, MAE00004, HOUR METER SCREWS, TO REFLECT AS BUILT.
SWB	H	11/10/05	BWW	MOVED NOTES TO FACE OF DRAWING FOR CLARITY. REMOVED NOTE 1 FOR REPLACEMENT OF 839701 WHICH IS NOT NECESSARY AND NOTE 3 FOR MARATHON MOTOR #2ZD56B17F5310FP, MOTOR IS NO LONGER PURCHASED.