



McElroy Manufacturing, Inc.
 The leader by design.
 Tulsa, Oklahoma U.S.A.

DRAWN: BA	CHECK: RAD	APPRV'D: B	DATE: 05/24/95	DWG No: 839700	SHT No: 3A	REV No: E	PART No: 839702
#28 ELECTRICAL BOX/MOTOR SUB-ASSEMBLY 100V, 50/60Hz, 1Ph							CAD No: 839702

NOTE: THIS DRAWING AND THE INFORMATION CONTAINED THEREIN IS THE CONFIDENTIAL AND PROPRIETARY PROPERTY OF McElroy Manufacturing, Inc. THE DRAWING IS NOT TO BE REPRODUCED IN ANY MANNER, SUBMITTED OUTSIDE PARTIES FOR EXAMINATION, OR USED DIRECTLY OR INDIRECTLY FOR THE PURPOSES OTHER THAN THOSE FOR WHICH IT WAS FURNISHED WITHOUT WRITTEN PERMISSION OF McElroy Manufacturing, Inc.

NOTES:

1. ITEMS 26, 27, 28 AND 29 ARE NOT SHOWN ON DRAWING.
2. INSULATE LEADS OF RV1 WITH INSULATION STRIPPED FROM WIRE USED IN ASSEMBLY.
3. CONNECT MOTOR FOR CLOCKWISE ROTATION.
4. ITEMS SHOWN IN PARENTHESIS REFLECT QUANTITIES IN A LOCAL GROUP AND MAY NOT INDICATE TOTAL ASSEMBLY QUANTITIES.

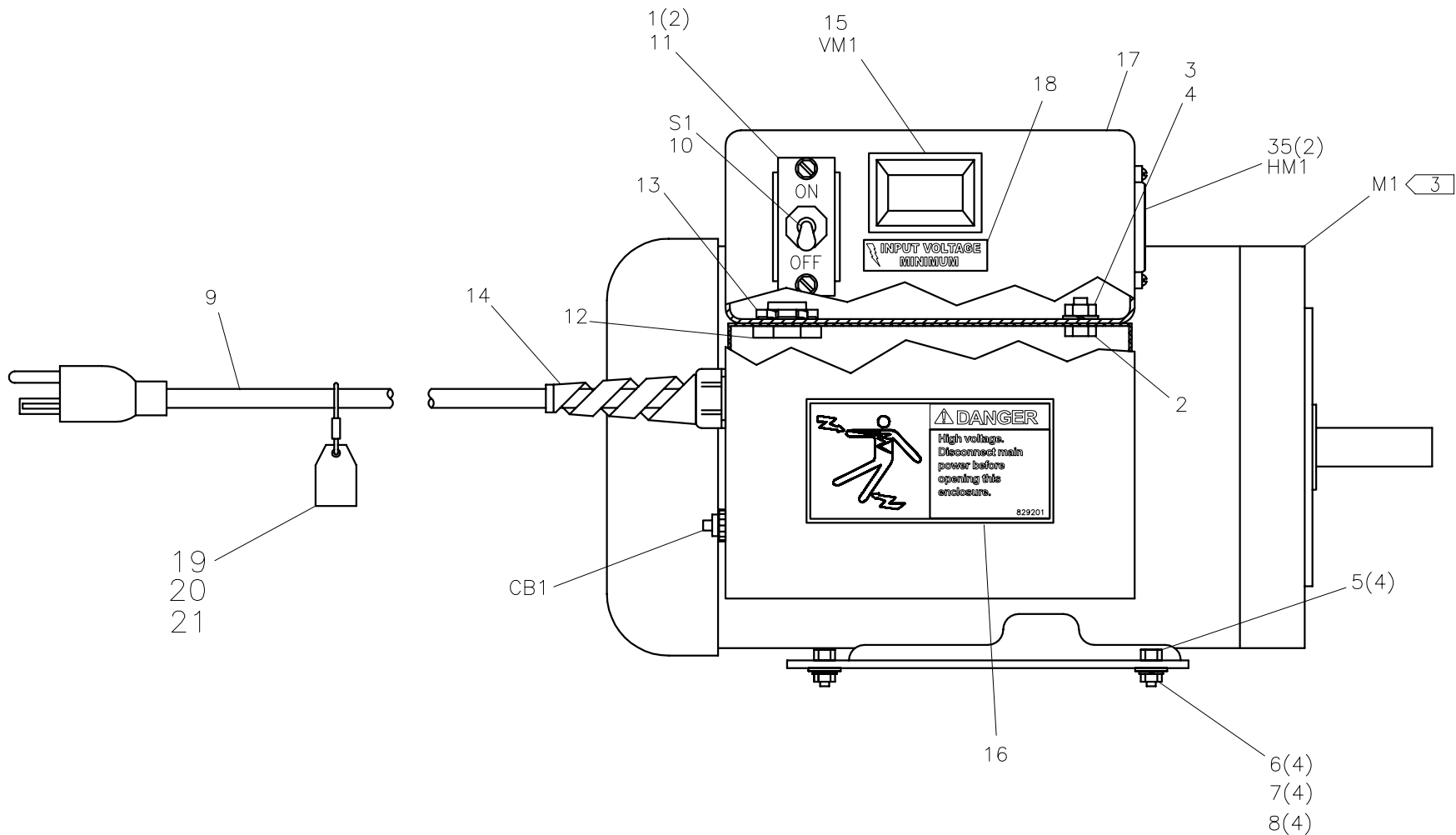



McElroy Manufacturing, Inc.
 The leader by design.
 Tulsa, Oklahoma U.S.A.

DRAWN: TLW	CHECK: SWB	APPRV'D: B	DATE: 02/20/96	DWG No: 839700	SHT No: 3B	REV No: E	PART No: 839702
#28 ELECTRICAL BOX/MOTOR SUB-ASSEMBLY 100V, 50/60Hz, 1Ph							CAD No: 839702

NOTE: THIS DRAWING AND THE INFORMATION CONTAINED THEREIN IS THE CONFIDENTIAL AND PROPRIETARY PROPERTY OF McElroy Manufacturing, Inc. THE DRAWING IS NOT TO BE REPRODUCED IN ANY MANNER, SUBMITTED OUTSIDE PARTIES FOR EXAMINATION, OR USED DIRECTLY OR INDIRECTLY FOR THE PURPOSES OTHER THAN THOSE FOR WHICH IT WAS FURNISHED WITHOUT WRITTEN PERMISSION OF McElroy Manufacturing, Inc.

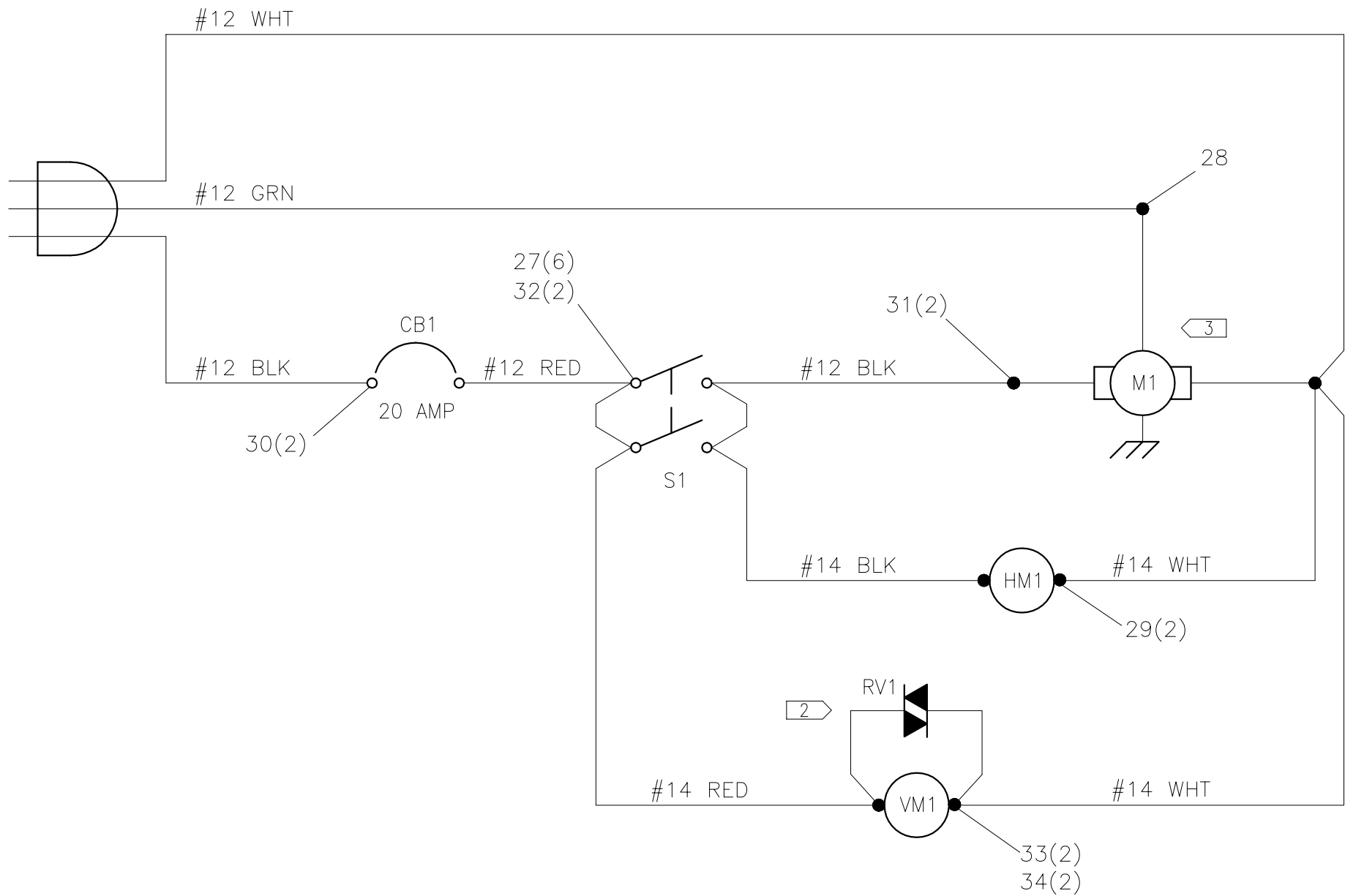

**#28 ELECTRICAL BOX / MOTOR SUB-ASSEMBLY
100V, 50/60 Hz, 1 Ph**

PARTS LIST

ITEM	PART NO.	QTY	DESCRIPTION
	839702		ASSEMBLY
CB1	MLN00241	1	20 AMP CIRCUIT BREAKER
HM1	MKH00005	1	A/C MULTI-RANGE HOUR METER
M1	837803	1	100, 50/60 MOTOR MODIFICATION
S1	MKE00004	1	SWITCH
VM1	MKH00080	1	PANEL MOUNT DIGITAL VOLTMETER
RV1	MQH00031	1	275V, 23 JOULES MOV
1	MAH00036	2	#6-32 NC X 3/8 LG HWH TC SCREW
2	MAB00002	1	1/4-20 NC X 1/2 LG HHCS
3	MBA00005	1	1/4-20 NC FINISH HEX NUT
4	MBE00005	1	1/4 REGULAR SPLIT LOCK WASHER
5	MAB00033	4	5/16-18 NC X 1 LG HHCS
6	MBA00006	4	5/16-18 NC FINISH HEX NUT
7	MBE00006	4	5/16 REGULAR SPLIT LOCK WASHER
8	MBF00006	4	5/16 TYPE "A" WIDE FLAT WASHER
9	1219005	1	#28 20AMP/120V POWER CORD ASSEMBLY
10	MLG00001	1	SWITCH GUARD
11	MLH00001	1	SWITCH BOOT
12	MLN00026	1	1/2" NPT CHASE NIPPLE
13	MLN00100	1	1/2" CONDUIT LOCKNUT
14	MLK00062	1	STRAIN RELIEF CONNECTOR
15	MLN00384	1	VOLTMETER BEZEL
16	829201	1	DANGER HIGH VOLTAGE LABEL
17	837902	1	ELECTRICAL BOX MODIFICATION
18	816335	1	85 MINIMUM INPUT VOLTAGE LABEL
19	816334	1	100V, 20A LABEL
20	MJQ00025	0.25 FT	COATED CABLE
21	MJQ00026	1	FERRULE
22	MLL00002	1 FT	#14 MTW / TEW WIRE, BLACK
23	MLL00052	1 FT	#14 MTW / TEW WIRE, WHITE
24	MLL00058	1 FT	#14 MTW / TEW WIRE, RED
25	MLL00003	1 FT	#12 MTW / TEW WIRE, BLACK
26	MLL00051	1 FT	#12 MTW / TEW WIRE, RED
27	MLM00171	6	RING TERMINAL
28	MLM00010	1	CONNECTOR
29	MLM00017	2	1/4 FEMALE DISCONNECT
30	MLM00085	2	INSULATED TERMINAL
31	MLM00034	2	TWIST LOCK CONNECTOR, YELLOW
32	MLM00119	2	RING TERMINAL
33	MLM00120	2	FORK TERMINAL
34	MLM00092	2	FORK TERMINAL
35	MAE00004	2	#4-40NC x 3/8 LG. BHSCS SS

DRAWING REVISION HISTORY LISTING

PART NO: 839702
DESCRIPTION: #28 ELECTRICAL BOX/MOTOR SUB-ASSEMBLY 100V , 50/60Hz, 1Ph

<u>APPR.</u>	<u>REV</u>	<u>DATE</u>	<u>BY</u>	<u>DESCRIPTION OF REVISION</u>
	A	9/18/95	TLW	DXF SHT 3 & 4 from ORCAD to Autocad.
	-----	11/7/96	SWB	Corrected parts list for item M1 from part no. 837801 to 837803
SWB	-----	1/8/97	AH	Joined 8397S03 & 8397S04 CAD files together and renamed to 839700.DWG. Incremented SHT.4 from NO REV to "A" REV in order to sync with SHT.3
TLW	B	7/21/00	B	Revised ITEM HMI Hour Meter MKH00005 to a multi-range meter. Corrected QTY of ITEM 18 MLM00001 Ring Terminal from 5 to 4 and added WP21 location. Added ITEM 30 MLM00017 Quick Slide Connectors at WP9 & 10. See PCR 99037.
RAD	C	01/22/02	BEA	Updated drawings from ORCAD to current methods. Renamed drawings 839700 Sheets 3A and 3B instead of Sheets 3 and 4 to combine BOM. Deleted MLM00001 and MLM00016. Added MLM00010, MLM00034, MLL00058, MLM00092, MLM00120 & MLM00171. Changed QTY of MLL00002 from 25FT to 1FT. Changed QTY of MLL00052 from 2 FT to 1 FT. Changed QTY of MLM00119 from 6 to 2.
SWB	--	05/03/04	BWW	CHANGED ITEM 9 FROM MLE00041 TO 1219005 DUE TO LOW VOLUME REQUIREMENTS.
BEA	D	11/30/04	BWW	REVISED TO ADD ITEM 35 MAE00004 QTY 2 FOR HOUR METER ATTACHMENT.
SWB	E	11/11/05	BWW	MOVED NOTES TO FACE OF DRAWING AND ADDED NOTE 4 FOR CLARITY.