

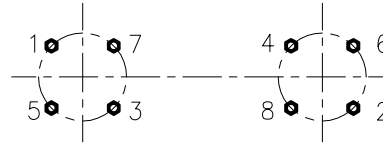

McElroy Manufacturing, Inc.
 The leader by design.
 Tulsa, Oklahoma U.S.A.

DRAWN: TLW	CHECK: RLE	APPRV'D: DWP	DATE: 11/12/96	DWG No: 842900	SHT No: 1	REV No: B	PART No: 842901
Mc28 Pit Bull LOW FORCE CYLINDER ASSEMBLY SET (XHV)							CAD No: 842901

NOTE: THIS DRAWING AND THE INFORMATION CONTAINED THEREIN IS THE CONFIDENTIAL AND PROPRIETARY PROPERTY OF McElroy Manufacturing, Inc. THE DRAWING IS NOT TO BE REPRODUCED IN ANY MANNER, SUBMITTED OUTSIDE PARTIES FOR EXAMINATION, OR USED DIRECTLY OR INDIRECTLY FOR THE PURPOSES OTHER THAN THOSE FOR WHICH IT WAS FURNISHED WITHOUT WRITTEN PERMISSION OF McElroy Manufacturing, Inc.



TIE ROD TORQUE PROCEDURE:
 TIGHTEN TIE ROD NUTS IN
 SEQUENCE 16-20 Ft. Lbs.

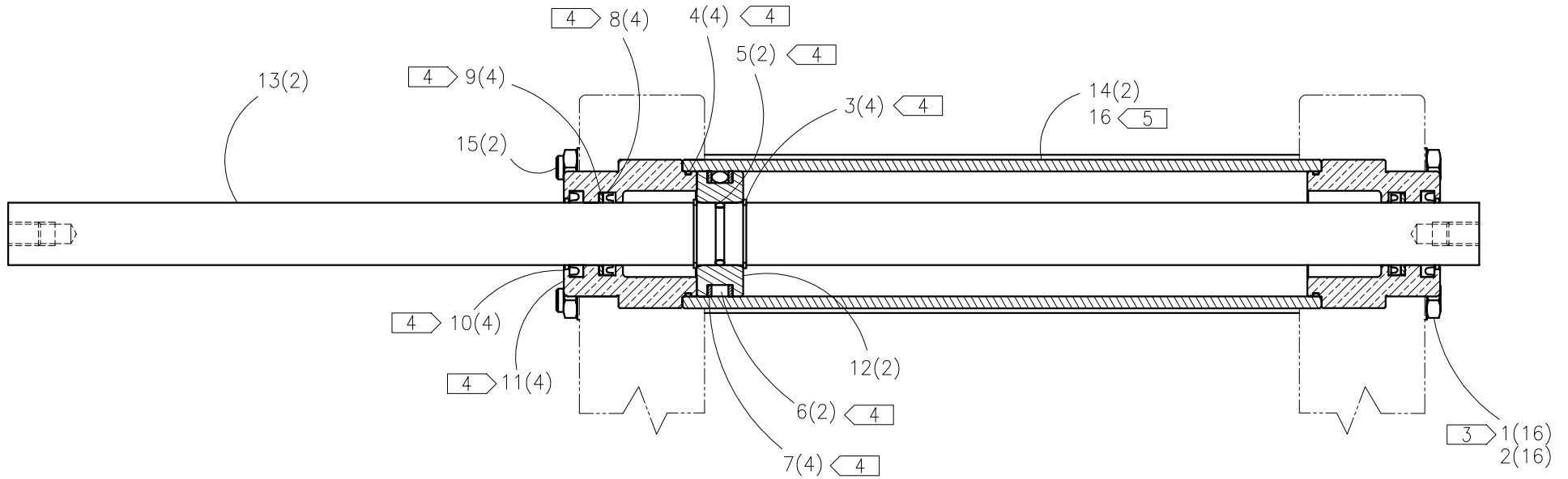

Mc28 Pit Bull™ LOW FORCE CYLINDER ASSEMBLY SET (XHV)Parts List

ITEM	PART NO.	QTY.	DESCRIPTION
	842901	1	ASSEMBLY
1	MBB00037	16	3/8-24NF FINISHED JAM NUT
2	MBG00001	16	3/8 TYPE 'AN' FLAT WASHER
3	MCB00006	4	EXT. SNAP RING
4	MDL00029	4	O'RING
5	MDL00028	2	O'RING
6	MDL00020	2	O'RING
7	MDL00022	4	BACK-UP RING
8	MDL00030	4	SEAL
9	MDL00031	4	WASHER
10	MDL00032	4	WIPER
11	800901	4	ROD GLAND
12	818801	2	XHV PISTON
13	843001	2	GUIDE ROD
14	842902	2	EXTRA HIGH VELOCITY CARRIAGE CYLINDER
15	843401	8	TIE ROD
16	816371	1	1.66 SQ. IN. TEPA LABEL

NOTES:

1. TOTAL EFFECTIVE PISTON AREA = 1.66 IN. SQ.
2. TORQUE TIE ROD STUDS 15-18 FT. LBS.
3. INSTALL TIE RODS FLUSH WITH JAM NUTS ON THIS END ONLY.
4. THESE ITEMS ARE PART OF PART #A820601 SEAL KIT.
5. ATTACH TO THE OUTSIDE OF ONE CARRIAGE CYLINDER.

DRAWING REVISION HISTORY LISTING

PART NO: 842901

DESCRIPTION: Mc28 Pit Bull™ LOW FORCE CYLINDER ASSEMBLY SET (XHV)

<u>APPR.</u>	<u>REV</u>	<u>DATE</u>	<u>BY</u>	<u>DESCRIPTION OF REVISION</u>
SWB	A	2/12/97	TLW	CHANGED DESCRIPTION FROM XH VELOCITY TO LOW FORCE AND PUT (XHV) ON THE END OF DESCRIPTION.
SWB	B	10/20/97	BB	ADDED ITEM #16 816371 TEPA LABEL & NOTE 5. ADDED TIE ROD TORQUE PROCEDURE.