

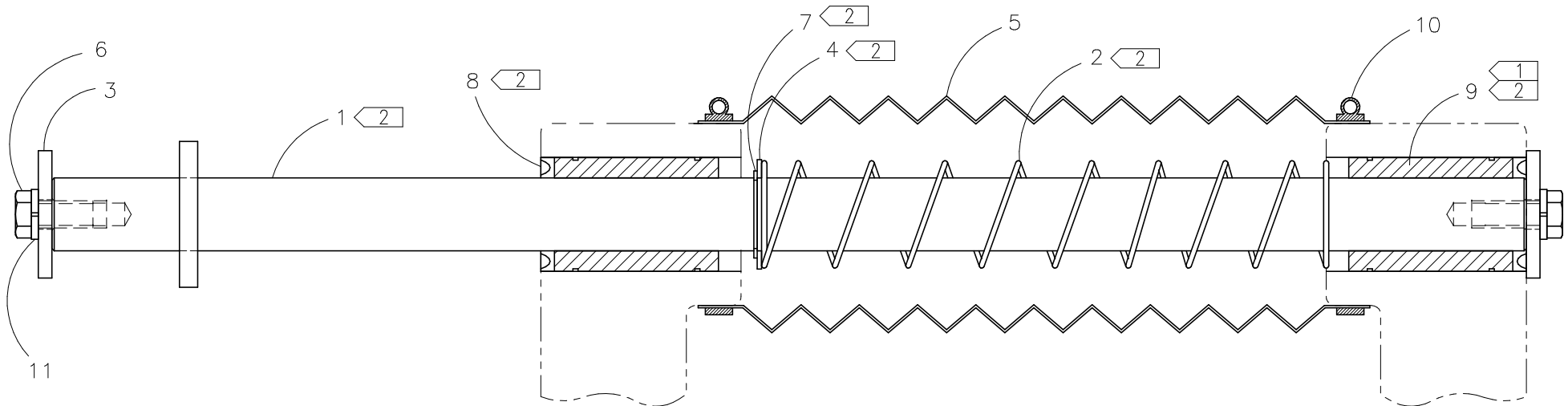

McElroy Manufacturing, Inc.
The leader by design.
© Tulsa, Oklahoma U.S.A.

DRAWN: AH	CHECK: SWB	APPRV'D: B	DATE: 1/8/97	DWG No: 850000	SHT No: 1	REV No: A	PART No: 850001
#28 FACER PIVOT SHAFT ASSEMBLY							CAD No: 850001

NOTE: THIS DRAWING AND THE INFORMATION CONTAINED THEREIN IS THE CONFIDENTIAL AND PROPRIETARY PROPERTY OF McElroy Manufacturing, Inc. THE DRAWING IS NOT TO BE REPRODUCED IN ANY MANNER, SUBMITTED OUTSIDE PARTIES FOR EXAMINATION, OR USED DIRECTLY OR INDIRECTLY FOR THE PURPOSES OTHER THAN THOSE FOR WHICH IT WAS FURNISHED WITHOUT WRITTEN PERMISSION OF McElroy Manufacturing, Inc.



#28 FACER PIVOT SHAFT ASSEMBLY

PARTS LIST

ITEM	PART NO.	QTY	DESCRIPTION
	850001	1	ASSEMBLY
1	814002	1	FACER PIVOT SHAFT
2	815502	1	SPRING
3	815601	2	WASHER
4	815602	1	WASHER
5	836401	1	ROD BOOT
6	MAB00063	2	3/8-16 NC X 3/4" LG. HHCS
7	MCB00006	1	EXT SNAP RING
8	MDL00045	2	SEAL
9	MDM00035	2	LINEAR BALL BEARING
10	MFD00049	2	HOSE CLAMP
11	MBE00007	2	3/8" REGULAR SPLIT LOCK WASHER

NOTES:

1. INSTALL WITH LOCTITE PRIMER T AND LOCTITE 601.
CAUTION: APPLY THIN LAYER OF LOCTITE TO O.D. OF BEARING. EXCESSIVE AMOUNT MAY BLEED INTO BALL CAVITY & LOCK-UP BEARINGS.
ALLOW 30 MIN.TO CURE.
2. THESE ITEMS ARE PART OF PART NO. A828601 FACER PIVOT SHAFT REPLACEMENT KIT.

DRAWING REVISION HISTORY LISTING

PART NO: 850001

DESCRIPTION: #28 FACER PIVOT SHAFT ASSEMBLY

<u>APPR.</u>	<u>REV</u>	<u>DATE</u>	<u>BY</u>	<u>DESCRIPTION OF REVISION</u>
TLW	A	12/16/97	TGW	ADDED ITEM 11 P/N MBE00007, QTY (2), 3/8" LOCK WASHER.
SWB	--	01/21/03	BWW	ADDED CAUTION NOTE FOR APPLICATION OF LOCTITE TO LINEAR BEARINGS.