

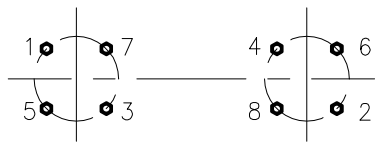

#28 HIGH FORCE CYLINDER ASSEMBLY SET (STD)

NOTE: THIS DRAWING AND THE INFORMATION CONTAINED THEREIN IS THE CONFIDENTIAL AND PROPRIETARY PROPERTY OF McElroy Manufacturing, Inc. THE DRAWING IS NOT TO BE REPRODUCED IN ANY MANNER, SUBMITTED OUTSIDE PARTIES FOR EXAMINATION, OR USED DIRECTLY OR INDIRECTLY FOR THE PURPOSES OTHER THAN THOSE FOR WHICH IT WAS FURNISHED WITHOUT WRITTEN PERMISSION OF McElroy Manufacturing, Inc.



TIE ROD TORQUE PROCEDURE:  
TIGHTEN TIE ROD NUTS IN  
SEQUENCE 16-20 Ft. Lbs.

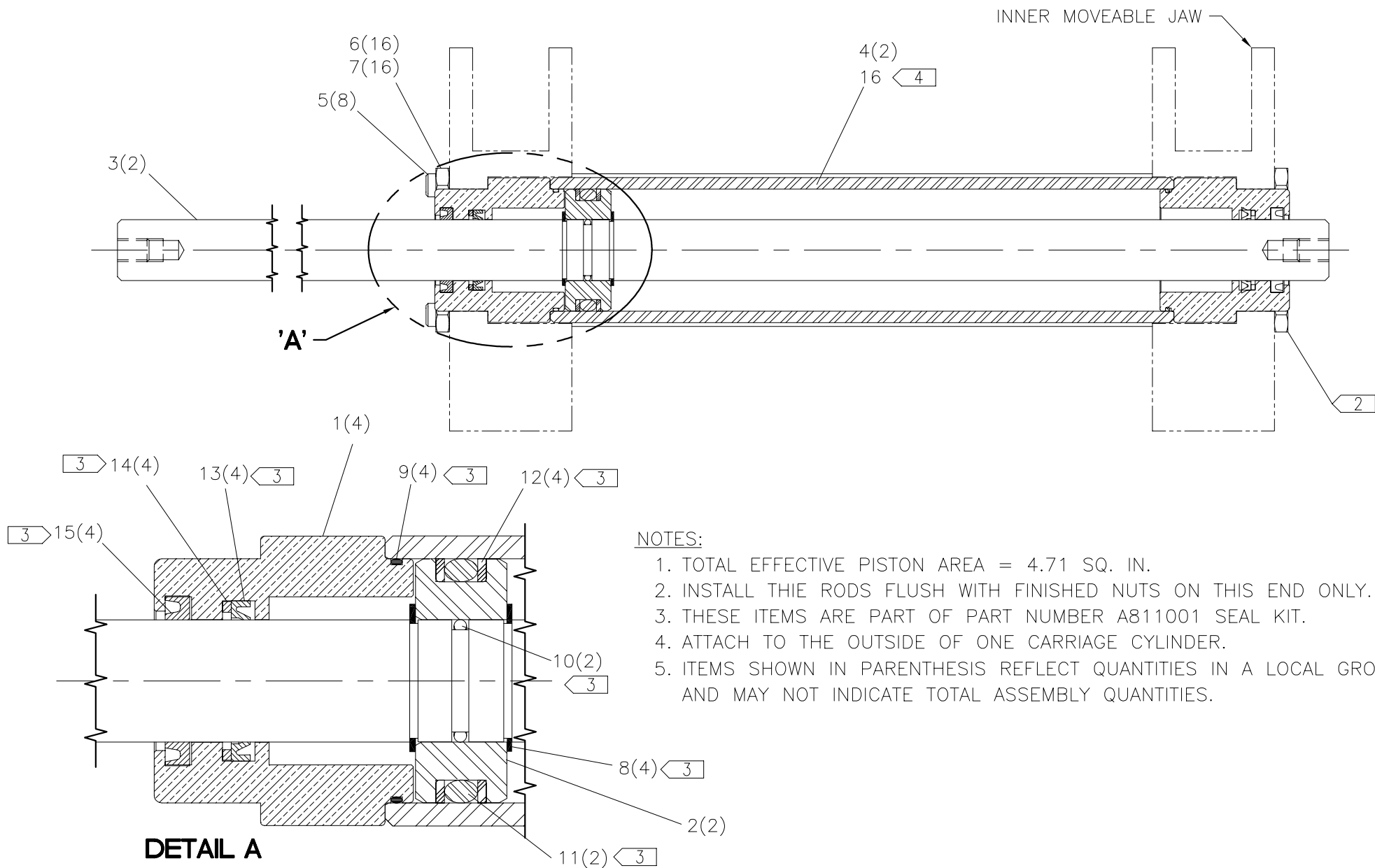

**DETAIL A**

NOTES:

1. TOTAL EFFECTIVE PISTON AREA = 4.71 SQ. IN.
2. INSTALL THE RODS FLUSH WITH FINISHED NUTS ON THIS END ONLY.
3. THESE ITEMS ARE PART OF PART NUMBER A811001 SEAL KIT.
4. ATTACH TO THE OUTSIDE OF ONE CARRIAGE CYLINDER.
5. ITEMS SHOWN IN PARENTHESIS REFLECT QUANTITIES IN A LOCAL GROUP AND MAY NOT INDICATE TOTAL ASSEMBLY QUANTITIES.

**#28 HIGH FORCE CYLINDER ASSEMBLY SET (STD)**PARTS LIST

ITEM	PART NO.	QTY	DESCRIPTION
	<b>840301</b>		<b>ASSEMBLY</b>
1	800901	4	ROD GLAND
2	802701	2	PISTON
3	813701	2	GUIDE ROD
4	813801	2	HYDRAULIC CYLINDER
5	1802001	8	TIE ROD
6	MBA00047	16	3/8-24NF FINISHED HEX NUT
7	MBG00001	16	3/8 TYPE 'AN' FLAT WASHER
8	MCB00006	4	EXTERNAL SNAP RING
9	MDL00001	4	O-RING
10	MDL00002	2	O-RING
11	MDL00012	2	O-RING
12	MDL00021	4	BACK-UP RING
13	MDL00030	4	SEAL
14	MDL00031	4	WASHER
15	MDL00032	4	WIPER
16	816343	1	4.71 SQ. IN. TEPA LABEL

## DRAWING REVISION HISTORY LISTING

**PART NO:** 840301  
**DESCRIPTION:** #28 HIGH FORCE CYLINDER ASSEMBLY SET (STD)

<u>APPR.</u>	<u>REV</u>	<u>DATE</u>	<u>BY</u>	<u>DESCRIPTION OF REVISION</u>
SWB	A	11/27/95	TLW	IGES OUT OF BRAVO INTO AUTOCAD.
SWB	B	1/8/97	AH	REMOVED FACER PIVOT SHAFT COMPONENTS TO CREATE PART NUMBER & DRAWING 850001 #28 FACER PIVOT SHAFT ASSEMBLY.
SWB	C	2/12/97	TLW	ADDED HIGH FORCE AND (STD) TO DESCRIPTION.
SWB	-	6/6/97	TLW	CHANGED ITEM #6 MBB00037 JAM NUT TO MBA00047 FINISHED NUT. PROBLEM WITH JAM NUT STRIPPING WHEN TIGHTEN TO TORQUE SPECIFIED.
SWB	-	7/22/97	BB	CHANGED ITEM #5 813901 TIE ROD TO 1802001. 8" TIE RODS WERE CONSOLIDATED W/18".
SWB	D	10/20/97	BB	ADDED ITEM #16 816343 TEPA LABEL & NOTE 5.
TLW	E	11/17/97	JPS	ADDED INNER MOVABLE JAW FOR CLARIFICATION.
SWB	F	03/22/05	BWW	REVISED TO ADD DETAIL A AND NOTE 5 FOR CLARITY. ADDED ITEM QUANTITIES TO MATCH CURRENT STANDARDS.