



McElroy Manufacturing, Inc.
 The leader by design.
 Tulsa, Oklahoma U.S.A.

DRAWN: AH	CHECK: TLW	APPRV'D: SWB	DATE: 2/26/99	DWG No:	SHT No:	REV No: B	PART No:
#2LC BUTT FUSION MACHINE GROUPING FOR 217200 ASSEMBLIES							CAD No: _ASSY2LC

NOTE: THIS DRAWING AND THE INFORMATION CONTAINED THEREIN IS THE CONFIDENTIAL AND PROPRIETARY PROPERTY OF McElroy Manufacturing, Inc. THE DRAWING IS NOT TO BE REPRODUCED IN ANY MANNER, SUBMITTED OUTSIDE PARTIES FOR EXAMINATION, OR USED DIRECTLY OR INDIRECTLY FOR THE PURPOSES OTHER THAN THOSE FOR WHICH IT WAS FURNISHED WITHOUT WRITTEN PERMISSION OF McElroy Manufacturing, Inc.

- 1 - 217201 #2LC BUTT FUSION MACHINE ASSEMBLY
- 2 - 216101 2" FACER ASSEMBLY
- 3 - A215505 2" Multi-Mc BUTT PLATE HEATER ASSEMBLY 100-120V, 50/60Hz, 1Ph (INCLUDES 215505 W/ BUTT PLATES)
- 3 - A215506 2" Multi-Mc BUTT PLATE HEATER ASSEMBLY 200-240V, 50/60Hz, 1Ph (INCLUDES 215506 W/ BUTT PLATES)
- 4 - 218301 2" HEATER/FACER STAND ASSEMBLY

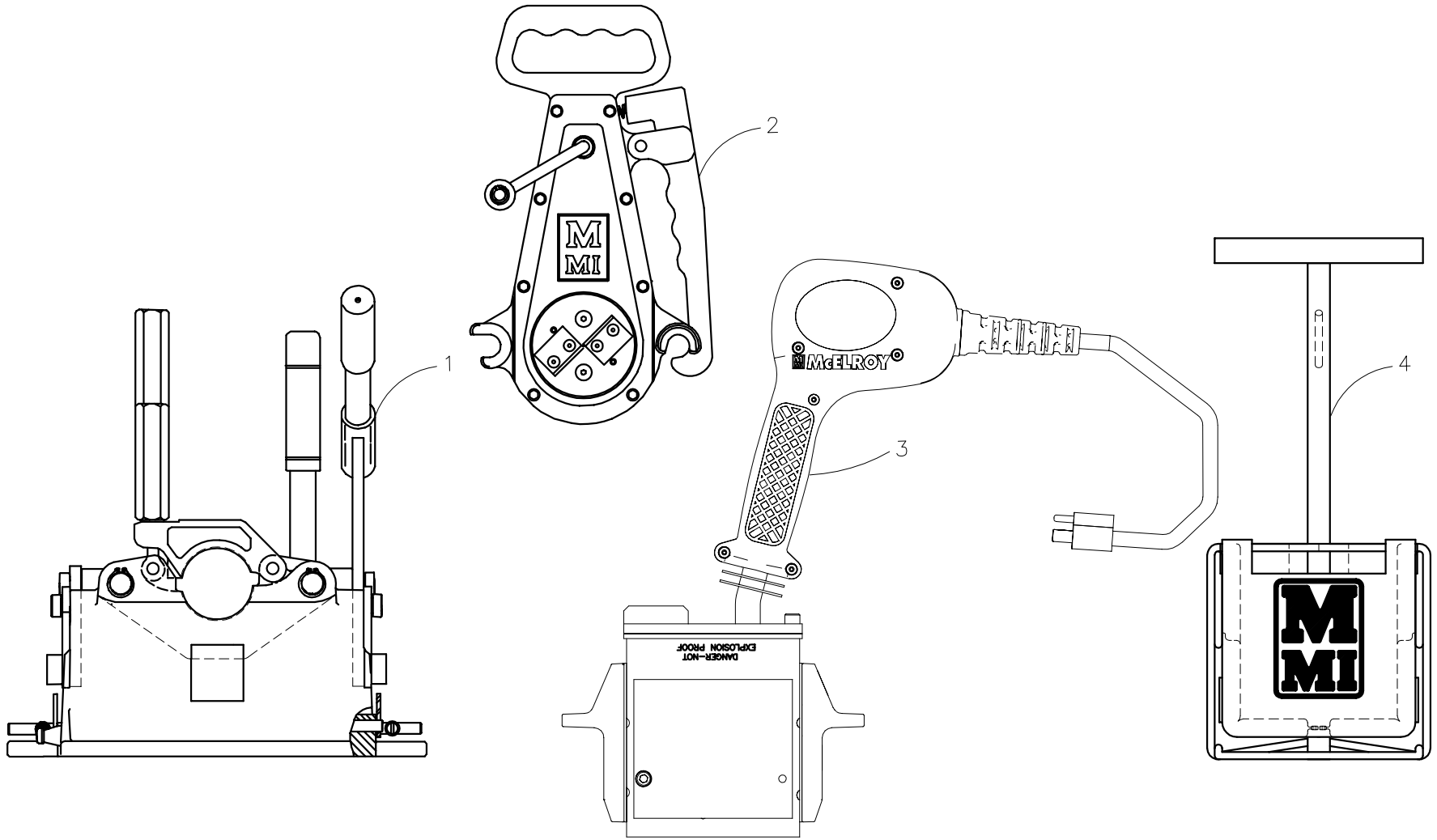

DRAWING REVISION HISTORY LISTING

PART NO: _ASSY2LC

DESCRIPTION: #2LC BUTT FUSION MACHINE GROUPING FOR 217200 ASSEMBLIES

<u>APPR.</u>	<u>REV</u>	<u>DATE</u>	<u>BY</u>	<u>DESCRIPTION OF REVISION</u>
TMT	A	05/13/02	BWW	REVISED TO REPLACE A215501 WITH A215503 AND A215502 WITH A215504 TO SHOW NEW HEATER ASSEMBLIES WITH ELECTRONIC CONTROL.
SWB	B	08/17/05	BWW	UPDATED ITEM 3 TO NEW STYLE HEATER WITH SHORTER HANDLE.