



McElroy Manufacturing, Inc.

The leader by design.

Tulsa, Oklahoma U.S.A.

DRAWN: AH

CHECK: TLW

APPRVD: SWB

DATE: 3/2/99

SHT No: 1

REV No: C

PART No: 218301

2" HEATER/FACER STAND ASSEMBLY

NOTE: THIS DRAWING AND THE INFORMATION CONTAINED THEREIN IS THE CONFIDENTIAL AND PROPRIETARY PROPERTY OF McElroy Manufacturing, Inc. THE DRAWING IS NOT TO BE REPRODUCED IN ANY MANNER, SUBMITTED TO OUTSIDE PARTIES FOR EXAMINATION, OR USED DIRECTLY OR INDIRECTLY FOR THE PURPOSES OTHER THAN THOSE FOR WHICH IT WAS FURNISHED WITHOUT WRITTEN PERMISSION OF McElroy Manufacturing, Inc.

NOTES:

1. ATTACH USING RUBBER ADHESIVE APPROX. 3/4" FROM THE BOTTOM OF VERTICLE TUBE.

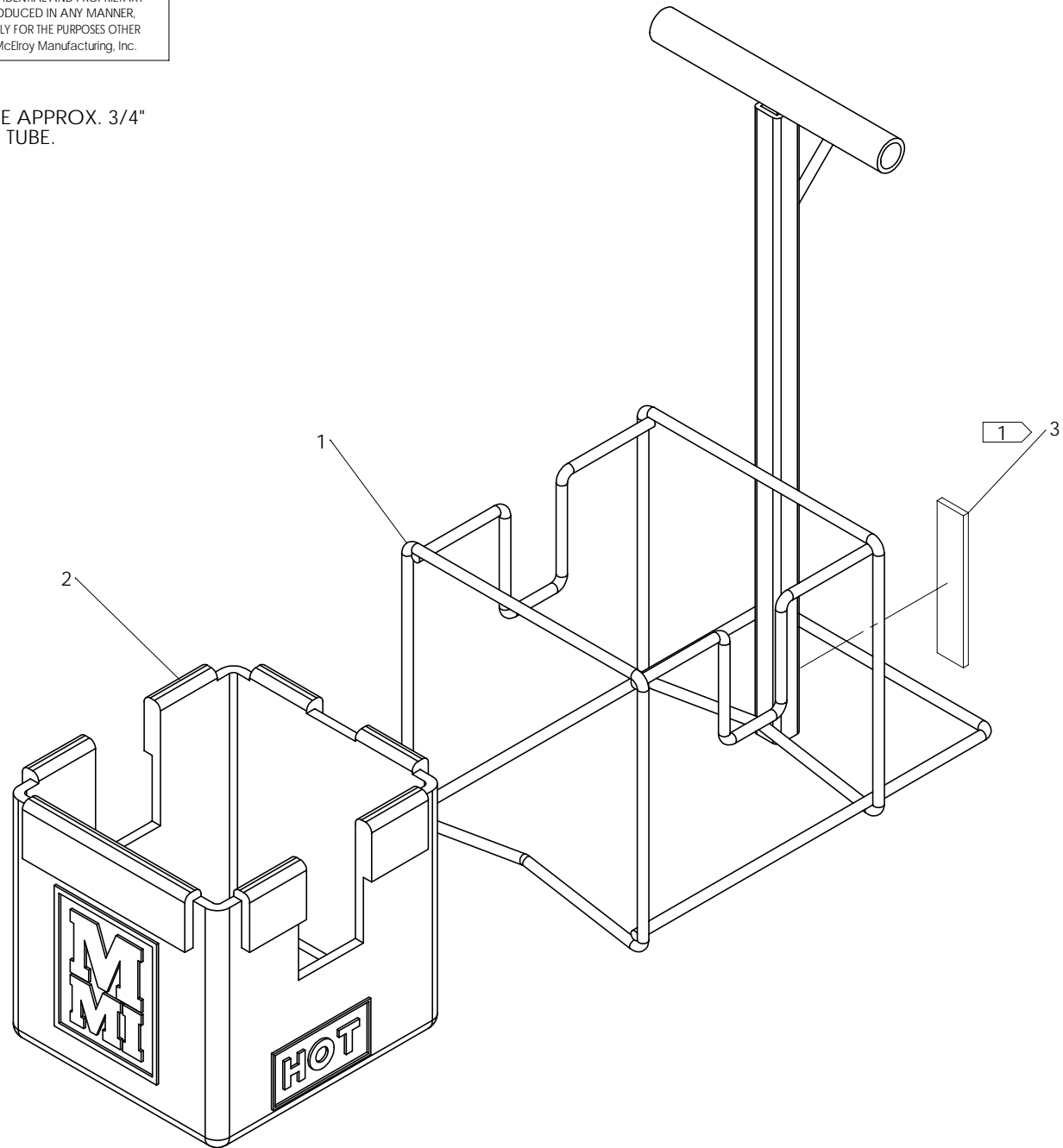

2" HEATER/FACER STAND ASSEMBLYPARTS LIST

ITEM	PART NO.	QTY	DESCRIPTION
	218301		Assembly
1	218302	1	HEATER AND FACER STAND WELDMENT
2	218303	1	HEATER BAG
3	MJQ00059	1	1/8 x 5/8 x 6 NEOPRENE RUBBER

DRAWING REVISION HISTORY LISTING

PART NO: 218301
DESCRIPTION: 2" HEATER/FACER STAND ASSEMBLY

<u>APPR.</u>	<u>REV</u>	<u>DATE</u>	<u>BY</u>	<u>DESCRIPTION OF REVISION</u>
TLW	B	3/16/99	AH	REDRAWN TO 'A' SIZE FORMAT
SWB	C	08/29/05	BWW	REVISED TO CREATE EXPLODED ISOMETRIC VIEW FOR CLARITY.