



McElroy Manufacturing, Inc.

The leader by design.

Tulsa, Oklahoma U.S.A.

DRAWN: RLE

CHECK: JAL

APPRVD: JRP

DATE: 9/20/04

SHT No: 6A

REV No: A

PART No: 215506

2" Multi-Mc BUTT PLATE HEATER ASSEMBLY 200-240V, 50/60Hz, 1Ph

NOTE: THIS DRAWING AND THE INFORMATION CONTAINED THEREIN IS THE CONFIDENTIAL AND PROPRIETARY PROPERTY OF McElroy Manufacturing, Inc. THE DRAWING IS NOT TO BE REPRODUCED IN ANY MANNER, SUBMITTED TO OUTSIDE PARTIES FOR EXAMINATION, OR USED DIRECTLY OR INDIRECTLY FOR THE PURPOSES OTHER THAN THOSE FOR WHICH IT WAS FURNISHED WITHOUT WRITTEN PERMISSION OF McElroy Manufacturing, Inc.

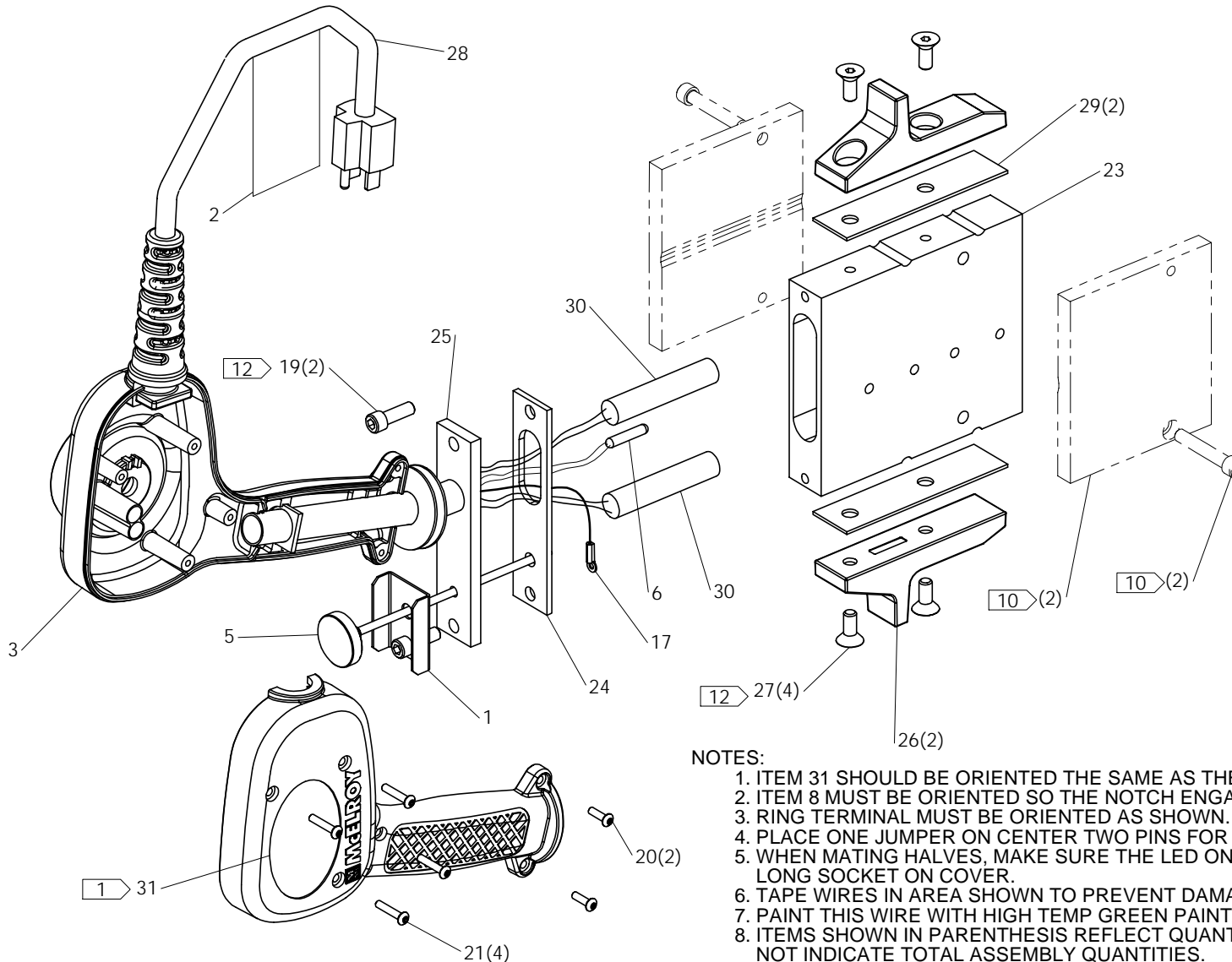

NOTES:

1. ITEM 31 SHOULD BE ORIENTED THE SAME AS THE MMI LOGO.
2. ITEM 8 MUST BE ORIENTED SO THE NOTCH ENGAGES THE KEY ON ITEM 3.
3. RING TERMINAL MUST BE ORIENTED AS SHOWN.
4. PLACE ONE JUMPER ON CENTER TWO PINS FOR 200-240V OPERATION.
5. WHEN MATING HALVES, MAKE SURE THE LED ON THE PC BOARD FITS INTO LONG SOCKET ON COVER.
6. TAPE WIRES IN AREA SHOWN TO PREVENT DAMAGE.
7. PAINT THIS WIRE WITH HIGH TEMP GREEN PAINT TO MARK AS A GROUND WIRE.
8. ITEMS SHOWN IN PARENTHESIS REFLECT QUANTITIES IN A LOCAL GROUP AND MAY NOT INDICATE TOTAL ASSEMBLY QUANTITIES.
9. SET AND CHECK TEMPERATURE PER ES389.
10. ORDER A215701 BUTT PLATE REPLACEMENT KIT FOR THESE PARTS.
11. ORDER A215506 FOR TOTAL ASSEMBLY WHICH INCLUDES BUTT PLATES AND SCREWS.
12. INSTALL WITH HIGH TEMPERATURE ANTI-SEIZE COMPOUND.



McElroy Manufacturing, Inc.

The leader by design.

Tulsa, Oklahoma U.S.A.

DRAWN: RLE

CHECK: JAL

APPRVD: JRP

DATE: 9/20/04

SHT No: 6B

REV No: A

PART No: 215506

2" Multi-Mc BUTT PLATE HEATER ASSEMBLY 200-240V, 50/60Hz, 1Ph

NOTE: THIS DRAWING AND THE INFORMATION CONTAINED THEREIN IS THE CONFIDENTIAL AND PROPRIETARY PROPERTY OF McElroy Manufacturing, Inc. THE DRAWING IS NOT TO BE REPRODUCED IN ANY MANNER, SUBMITTED TO OUTSIDE PARTIES FOR EXAMINATION, OR USED DIRECTLY OR INDIRECTLY FOR THE PURPOSES OTHER THAN THOSE FOR WHICH IT WAS FURNISHED WITHOUT WRITTEN PERMISSION OF McElroy Manufacturing, Inc.

240 VAC PLUG

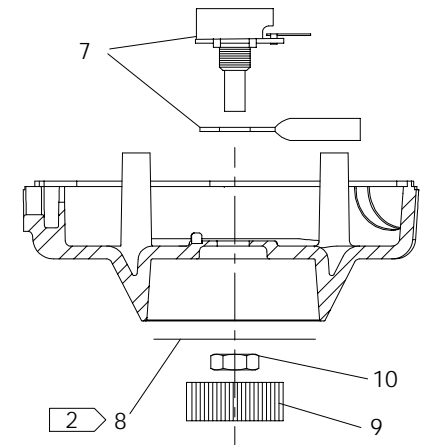
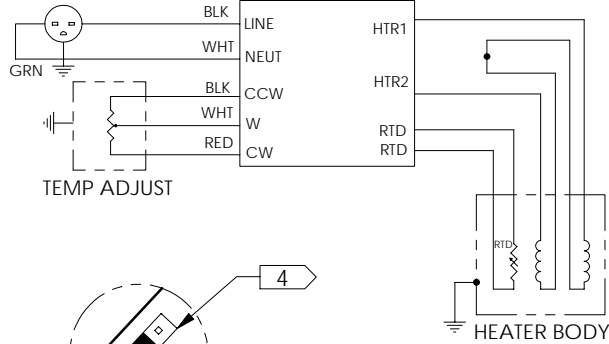

SECTION A-A

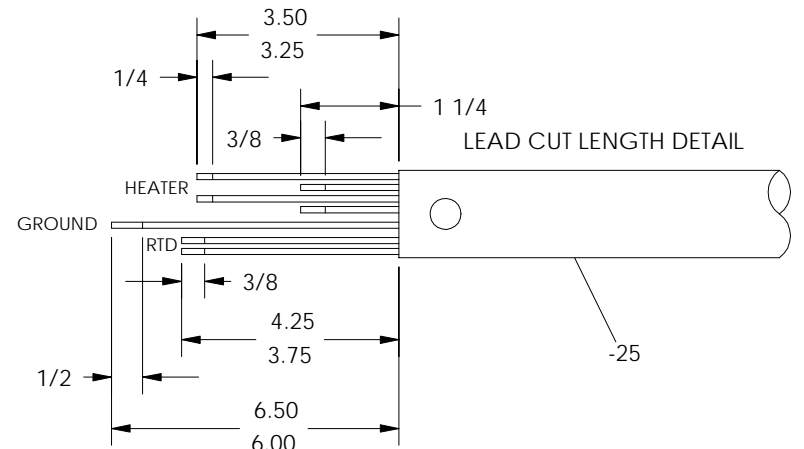
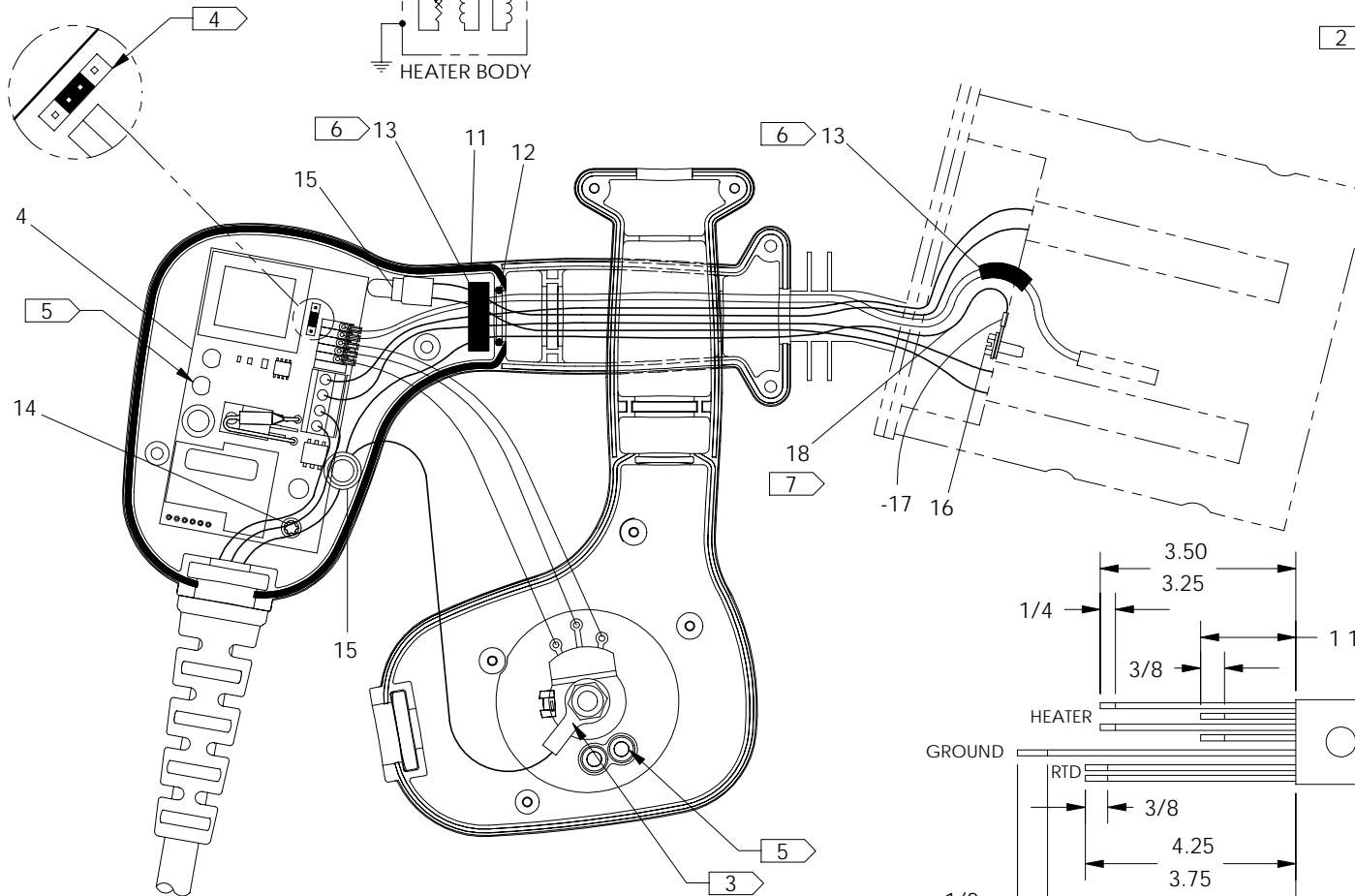

**2" Multi-Mc BUTT PLATE HEATER ASSEMBLY
200-240V, 50/60Hz, 1Ph**

Parts List

ITEM	PART NO.	QTY.	DESCRIPTION
	215506		ASSEMBLY
1	214801	1	Multi-Mc THERMAL GUARD
2	410906	1	DANGER NOT EXPLOSION PROOF TAG LABEL
3	437203	1	SMALL HEATER HANDLE/ENCLOSURE
4	T5030001	1	HEATER CONTROL PCB ASSEMBLY
5	MJK00001	1	5" LG., 150-750° F THERMOMETER
6	MKI00003	1	1" x 3/16 316SS 100 OHM PLATINUM RTD
7	T5030002	1	POTENTIOMETER ASSEMBLY
8	816382	1	TEMPERATURE SCALE LABEL
9	MJJ00023	1	CONTROL KNOB
10	MBA00067	1	HEX SEAL NUT
11	MDL00243	18IN	.070 DIA. BUNA-N O-RING STOCK
12	MDL00248	1	O-RING
13	MLN00219	8IN	FIBERGLASS TAPE
14	MAL00011	1	#6-19 x 1/4 LG. TORX T15 PAN HEAD SCREW
15	MLM00002	2	2/16-2/18 WIRE NUT
16	MAH00036	1	#6-32NC x 3/8 LG. HWH TC SCREW
17	MLM00004	1	RING TERMINAL
18	MLL00004	12IN	#18 TYPE TGGT ELECTRICAL WIRE
19	MAH00052	2	1/4-20NC x 3/4 LG. SHCS SS
20	MAL00013	2	#6-19 x 1/2 LG. TORX T15 PAN HEAD SCREW
21	MAL00010	4	#6-19 x 3/4 LG. TORX T15 PAN HEAD SCREW
22	A214102	1	SOCKET FUSION SCREW/DRIVER KIT (NOT SHOWN)
23	214501	1	Multi-Mc HEATER BODY
24	214701	1	Multi-Mc HEATER COVER PLATE GASKET
25	226701	1	HEATER HANDLE WELDMENT
26	215901	2	2" Multi-Mc HEATER SUPPORT BRACKET
27	MAH00073	4	1/4-20NC x 5/8 LG FHSCS SS
28	1854801	1	15AMP/250V POWER CORD
29	215902	2	2" Multi-Mc HEATER SUPPORT BRACKET GASKET
30	MLD00008	2	120V, 400W, 1/2 x 2-1/2 CARTRIDGE HEATER
31	8163107	1	MODEL 215506 PART NO. LABEL

DRAWING REVISION HISTORY LISTING

PART NO: 215506

DESCRIPTION: 2" Multi-Mc BUTT PLATE HEATER ASSEMBLY 200-240V, 50/60Hz, 1Ph

<u>APPR.</u>	<u>REV</u>	<u>DATE</u>	<u>BY</u>	<u>DESCRIPTION OF REVISION</u>
SWB	A	08/02/05	BWW	REVISED PICTORIALY TO SHOW EXPLODED ISOMETRIC VIEW ON SHT 6A & CONSOLIDATED ALL TO 2 SHEETS. UPDATED VIEW ON SHT 6B PICTORIALY TO SHOW REMOVAL OF UNNECESSARY GROUND WIRE BETWEEN POT SHAFT & POT TERMINAL. UPDATED GROUND SYMBOL LOCATION ON SCHEMATIC ACCORDINGLY. REMOVED MLM00010 AND CHANGED QTY OF MLM00002 FROM 1 TO 2 TO EASE ASSEMBLY.